



UTILITY PRODUCTS

VERSATILE. RELIABLE. DURABLE.



C O L U M B U S M C K I N N O N C O R P O R A T I O N

Whether repairing overhead power lines after a storm or performing routine maintenance on an electric power distribution system, Columbus McKinnon hoists and rigging products can help. With nearly 150 years of industry experience and well-known brands such as Little Mule and Coffing Hoists, we offer a large selection of products developed specifically for the needs of the utility industry.

Our portfolio of lineman's products, including strap hoists, lever tools and wire grips, are designed for safety and efficiency, helping utility professionals get the job done in even the most hazardous environments.



————— COLUMBUS MCKINNON FAMILY OF BRANDS —————





Built to stand the test of time,
wire grips and hoists from Columbus McKinnon
have been relied on by utility industry professionals
for generations.



Looking toward the future,
Columbus McKinnon will continue to innovate and develop products
for the ever-changing needs and applications of the utility industry.

TABLE OF CONTENTS

COMMON APPLICATIONS	6-7
ACSR & ALL-ALUMINUM CABLE SPECS	9
WIRE GRIPS	11-18
STRAP & CHAIN LEVER HOISTS	19-21
Little Mule® Lineman's Strap Hoist	22-35
Coffing® LSB-NC.....	36-37
Coffing® G Series.....	38-39
CM® Tornado 360°	40-41
CM® Bandit	44-45
CM® Series 602 & 603	46-47
BATTERY-POWERED HOIST	48-49
CM® BatteryStar™	50-53
UTILITY ACCESSORIES	54-55
Cant Hooks	56
Peavies	57
Pike Poles	58
Lifting Tongs	59
GENERAL RIGGING PRODUCTS	60-61
Chain.....	62-63
Chain Slings.....	64-65
Hooks	66-67
Rings and Links	68-69
Shackles	70
Wire Rope Attachments.....	71
Load Securement	72-73
TRAINING	74-75

Contact Columbus McKinnon Corporation

800.888.0985 716.689.5400

COMMON APPLICATIONS

Columbus McKinnon carries a large selection of hoist and rigging products designed to be used for a variety of utility transportation and distribution applications. Whether dead ending, sagging or splicing lines, we have what you need to safely complete the task at hand. See how our products can be used in a few of the most common utility applications below.

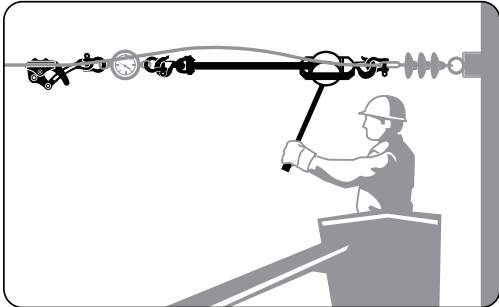

SAGGING USING A DYNAMOMETER

1. To begin, arrange your ratchet lever hoist, wire grip and dynamometer as shown in the diagram to the left. Use shackle connections where necessary.
2. Tension the strap hoist until the dynamometer reaches the tension required. Reference the necessary procedures and specifications set forth by your company to ensure the appropriate tension is reached.
3. To complete the job, alleviate the tension using the lever hoist handle. A drum knob can also be used to fully release the tension.

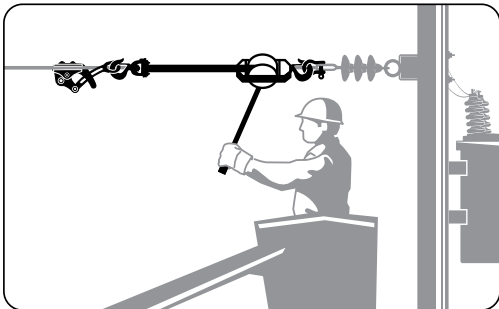

DEAD-ENDING

1. To begin, arrange your ratchet lever hoist and wire grip as shown in the diagram to the left. Use shackle connections where necessary.
2. Tension the strap hoist until the cable is aligned with the cable's ending point.
3. After reaching the appropriate level of tension, tighten the strap a bit more to account for loss of tension after the hoist is removed. Be sure to reference technical information to ensure the cable is not tensioned tighter than recommended by the manufacturer.
4. To complete the dead ending, alleviate the tension using the lever hoist handle. A drum knob can also be used to fully release the tension.

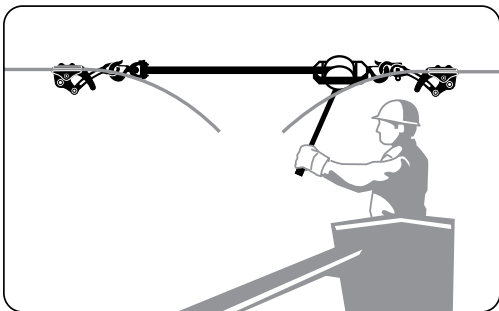

SPLICING

1. To begin, arrange the ratchet lever hoist and wire grips as shown in the diagrams to the left. Use shackle connections where necessary.
2. Attach the ratchet lever hoist to each wire grip. Tension the strap hoist until you reach the desired tension before splicing. Once you reach this tension, splice the wire in line with your company's procedures and guidelines.
3. To complete the job, alleviate the tension using the lever hoist handle. A drum knob can also be used to fully release the tension.

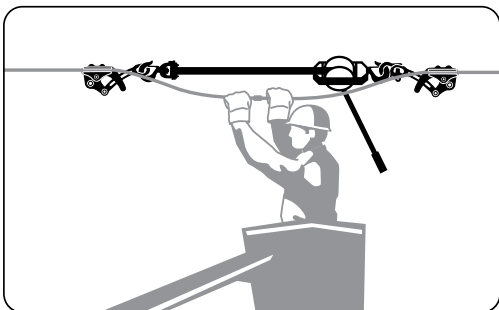

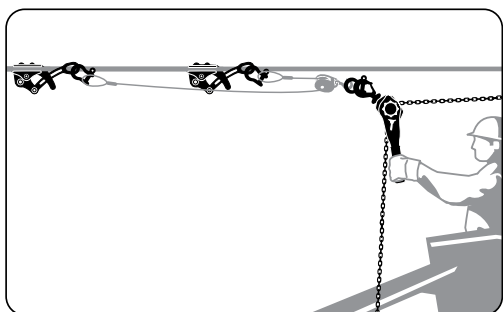
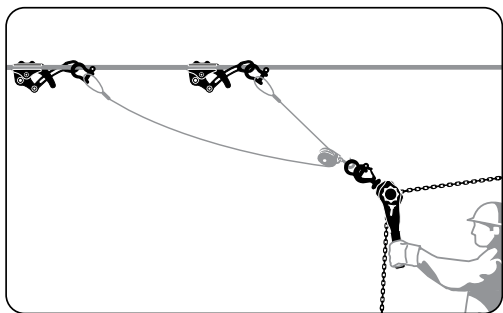

USING GRIPS IN TANDEM

One application where you may need to use grips in tandem would be when you need to ensure that the safe working load of a single grip is not exceeded. When using two grips together, the grips will share the weight of the load, increasing the safe working load limit of each grip by 1-1/2 times the lower capacity wire grip.

Another application where you may need to use two wire grips in tandem would be when the cable is at risk of being deformed. To prevent deformation, Columbus McKinnon suggests using two grips with ACSR or AAC conductors if the load will exceed either 12,500 lbs. (5,670 kg) or 40 percent of tensile strength of the conductor – whichever is less. When using ACSS conductors, we suggest utilizing two wire grips if the load will exceed 10,000 lbs. – or 40 percent of the strength of the conductor – again whichever of the two is lesser.

To use wire grips in tandem:

1. First, secure the two grips to the conductor. They should be attached approximately five feet apart. Use shackle connections where necessary.
2. Attach a pulley block to each grip. The pulley block should be attached to the eye of the wire grip. This will ensure that the grips share the load equally.
3. As shown in the image to the left, attach a chain hoist to the pulley block. Ensure the hoist is the appropriate capacity to handle the load.
4. Lastly, tension the hoist to the appropriate tension as shown in the image on the left.

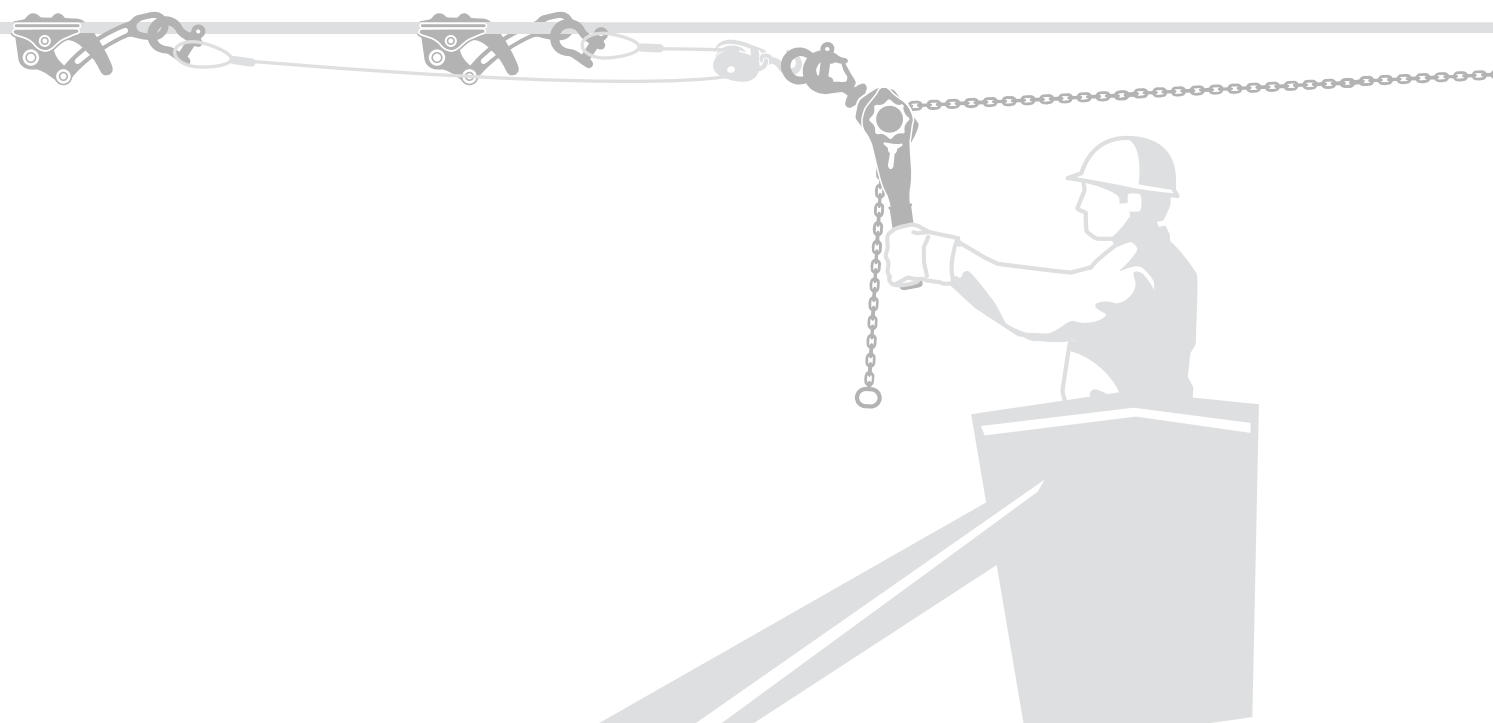



ACSR & ALL-ALUMINUM CABLE SPECIFICATIONS

The chart below identifies key properties of wire cables used in the utility industry. It includes cable strength, diameter and strand count, as well as code words registered with The Aluminum Association.

AWG or cmil Cable Size	ACSR*				All Aluminum			
	Code Word	# of Alum & Steel Strands	Diameter (in.)	Strength (lbs)	Code Word	# of Strands	Diameter (in)	Strength (lbs)
6	Turkey	6x1	.198	1190	Peachbell	7	.184	563
4	Swan	6x1	.250	1860	Rose	7	.232	881
4	Swanate	7x1	.257	2360	—	—	—	—
2	Sparrow	6x1	.316	2850	Iris	7	.292	1350
2	Sparate	7x1	.325	3640	—	—	—	—
1	Robin	6x1	.354	3550	Pansy	7	.328	1640
1/0	Raven	6x1	.398	4380	Poppy	7	.368	1990
2/0	Quail	6x1	.447	5300	Aster	7	.414	2510
3/0	Pigeon	6x1	.502	6620	Phlox	7	.464	3040
4/0	Penguin	6x1	.563	8350	Oxlip	7	.522	3830
266800 CM	Waxwing	18x1	.609	6880	Daisy	7	.586	4830
266800	Partridge	26x7	.642	11,300	Laurel	19	.593	4970
300000	Ostrich	26x7	.680	12,700	—	—	—	—
336400	Oriole	30x7	.741	17,300	Tulip	19	.666	6150
336400	Linnet	26x7	.720	14,100	—	—	—	—
397500	Lark	30x7	.806	20,300	Canna	19	.724	7110
397500	Ibis	26x7	.783	16,300	—	—	—	—
477000	Hen	30x7	.883	23,800	Cosmos	19	.792	8360
477000	Hawk	26x7	.858	19,500	Syringa	37	.795	8690
500000	Heron	30x7	.904	24,950	Zinnia	19	.811	8760
500000	—	—	—	—	Hyacinth	37	.813	9110
556500	Eagle	30x7	.953	27,800	Dahlia	19	.856	9750
556500	Dove	26x7	.927	22,600	Mistletoe	37	.858	9940
600000	—	—	—	—	Meadowsweet	37	.891	10,700
605000	Squab	26x7	.966	24,300	—	—	—	—
605000	Peacock	24x7	.953	21,600	—	—	—	—
636000	Egret	30x19	1.019	31,500	Orchid	37	.918	11,400
636000	Grosbeak	26x7	.990	25,200	—	—	—	—
636000	Goose	54x7	.977	23,300	—	—	—	—
666600	Flamingo	24x7	1.000	23,700	—	—	—	—
715500	Redwing	30x19	1.081	34,600	Violet	37	.974	12,800
715500	Starling	26x7	1.051	28,400	Nasturtium	61	.975	13,100
715500	Crow	54x7	1.036	25,900	—	—	—	—
795000	Mallard	30x19	1.140	38,400	Arbutus	37	1.026	13,900
795000	Drake	26x7	1.108	31,500	Lilac	61	1.028	14,300
795000	Condor	54x7	1.092	28,200	—	—	—	—
874500	Crane	54x7	1.146	31,000	Anemone	37	1.076	15,000
874500	—	—	—	—	Crocus	61	1.077	15,800
900000	Canary	54x7	1.162	31,900	—	—	—	—
954000	Cardinal	54x7	1.196	33,800	Magnolia	37	1.124	16,400
954000	—	—	—	—	Goldenrod	61	1.126	16,900
1033500	Curlew	54x7	1.245	36,600	Bluebell	37	1.170	17,700
1113000	Finch	54x19	1.293	39,100	Marigold	61	1.216	19,700
1192500	Grackle	54x19	1.338	41,900	Hawthorn	61	1.258	21,100
1272000	Pheasant	54x19	1.382	43,600	Narcissus	61	1.297	22,000
1351500	Martin	54x19	1.424	46,300	Columbine	61	1.339	23,400
1431000	Plover	54x19	1.465	49,100	Carnation	61	1.379	24,300
1510500	Parrot	54x19	1.505	51,700	—	—	—	—
1510500	—	—	—	—	Gladiolus	61	1.417	25,600
1590000	Falcon	54x19	1.545	54,500	Coreopsis	61	1.453	27,000
80000	Grouse	8x1	.367	5,200	—	—	—	—
101800	Petrel	12x7	.461	10,400	—	—	—	—
110800	Minorca	12x7	.481	11,300	—	—	—	—
134600	Leghorn	12x7	.530	13,600	—	—	—	—
159000	Guinea	12x7	.576	16,000	—	—	—	—
176900	Dotterel	12x7	.607	17,300	—	—	—	—
190800	Dorking	12x7	.631	18,700	—	—	—	—
203200	Brahma	16x19	.714	28,400	—	—	—	—
211300	Cochin	12x7	.664	20,700	—	—	—	—

*Aluminum Conductor Steel-Reinforced Cable (ACSR) is a high-strength, high-capacity conductor. Providing optimal strength, the concentric-lay-stranded conductor is made of high-purity round aluminum (1350-H19) wrapped around an inner core of galvanized steel wires.





WIRE GRIPS

12 **OVERVIEW, FEATURES & SPECIFICATIONS**

18 **CLEANING, LUBRICATING & INSPECTION**

WIRE GRIPS

CAPACITIES

1,000 to 20,000 lbs.

SPECIFICATIONS

- Models to fit wire gauge sizes of .04 in. to 1.25 in.
- Bulldog-type jaw or parallel jaw
- Standard and hot line models

When working with wire in utility applications, safety is of the utmost importance. Economical wire grips from Little Mule are designed to keep workers safe, while allowing them to efficiently get the job done.

Easy-to-use Little Mule wire grips can be used with a variety of wire sizes and types, so fewer grip changes are required. They also have large handle eye openings for easy opening, attaching and releasing to prevent lock ups. Made of forged steel, Little Mule grips are both durable and lightweight, making them ideal for a variety of utility jobs.

FEATURES & BENEFITS

VERSATILE

All models are rated for a variety of wire sizes and types, so fewer grip changes are required.

NO LOCK-UPS

Grips open easily and release instantly to quickly insert or remove wire.

LARGE HANDLE EYE OPENING

Accepts standard hooks and easily attaches to tackle blocks.

FORGED STEEL CONSTRUCTION

Durable yet lightweight.

YELLOW CHROMATE FINISH

Protects components from rust and corrosion.

OPTIONS

REPLACEMENT JAW

AGGRESSIVE TOOTH REPLACEMENT JAWS ARE AVAILABLE FOR 5,000-POUND CAPACITY WIRE GRIPS. PART NUMBER LMG45004A.



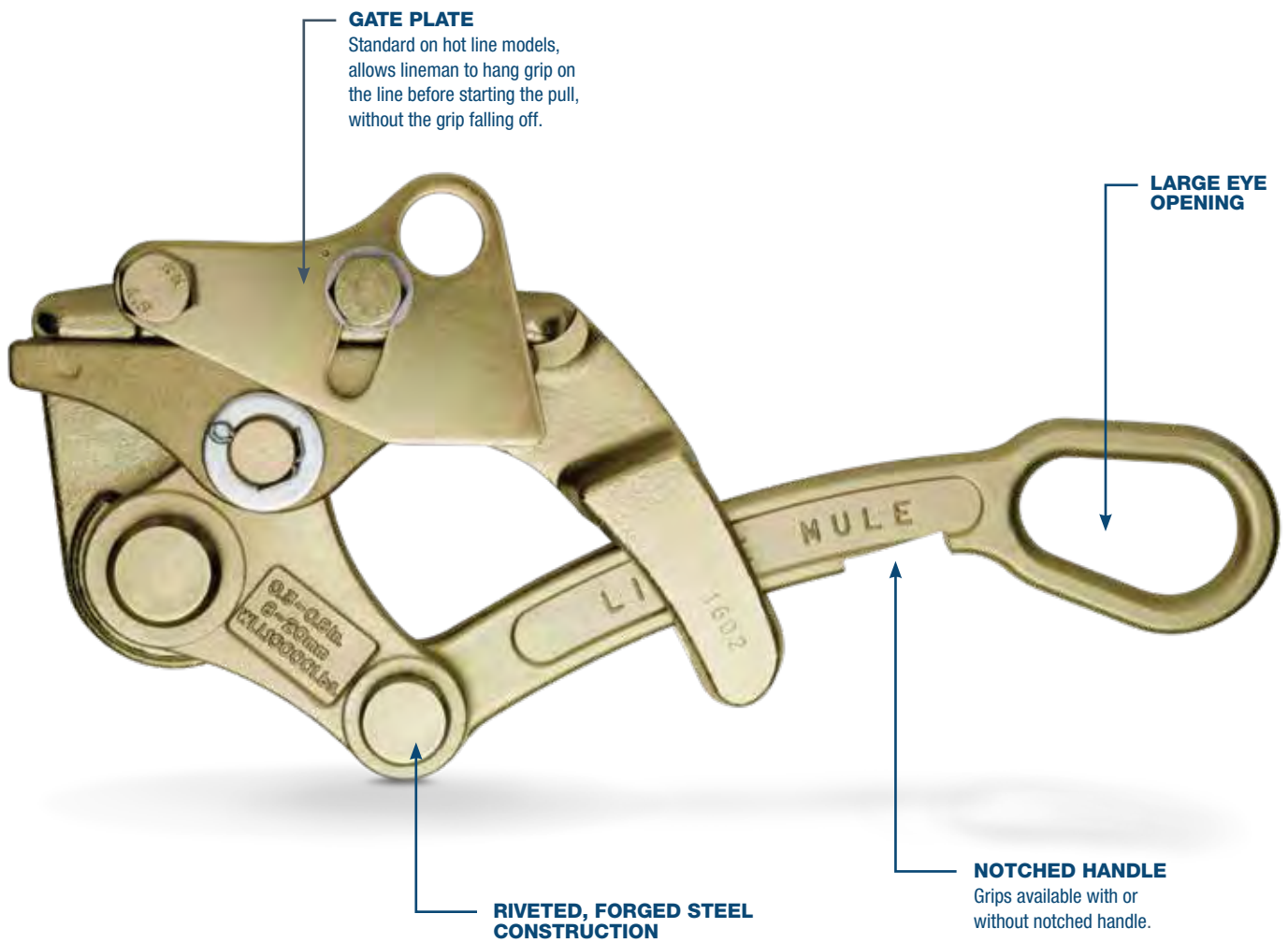

GATE PLATE
Standard on hot line models, allows lineman to hang grip on the line before starting the pull, without the grip falling off.

LARGE EYE OPENING

RIVETED, FORGED STEEL CONSTRUCTION

NOTCHED HANDLE
Grips available with or without notched handle.

HOW TO SELECT THE RIGHT GRIP

To select the best Little Mule wire grip for your application, we recommend taking the following steps:

Step 1: DETERMINE WHAT TYPE OF CABLE/WIRE IS BEING USED

What wire(s) type and size are you pulling?

Step 2: SELECT STANDARD OR HOT LINE MODEL

Will this grip be used on hot lines or will a standard grip suffice?

Step 3: CHOOSE YOUR GATE STYLE

Do you need a grip with spring-loaded or non-spring-loaded gates?

NOTE: Hot line models come with a special gate plate to prevent an open grip from falling off the wire.

Step 4: SELECT NOTCHED OR UN-NOTCHED HANDLE

A notched handle on spring-loaded models locks the grip in the open position for placement on or removal from wire, then releases instantly.

Step 5: PICK YOUR GRIP

Use the specifications you selected in steps 1 through 4 to find a grip in the chart on the next page. A visual depiction of each configuration is shown on previous page.

Little Mule Wire Grip (LMG4900)

20,000 lb. capacity
Parallel jaw style with fine teeth
Non-spring-loaded model with no notch



Little Mule Wire Grip (LMG1000)

1,000 lb. capacity
Bulldog jaw style with aggressive teeth
Standard spring-loaded model with no notch

SPECIFICATIONS

Capacity (lbs.)	Model	Product Code	Applicable Cable Types			Wire Size				Grip Type & Features						Jaw & Teeth Configurations				Handle Eye Opening Diameter (in.)	Weight lbs. (kg)
			Bare & Stranded Copper	ACSR & Aluminum Conductor	EHSC & Messenger Guy Wire	Minimum		Maximum		Model Type		Gate Style		Handle		Jaw Type	Teeth Type	Jaw Length			
						Size in. (mm)	Gauge	Size in. (mm)	Gauge	Standard	Hot Line	Non-Spring Loaded	Spring Loaded	Un-Notched	Notched			Teeth (in.)	Mount (in.)		
1,000	LMG1000	04451W			✓	.04 (1.02)	18AWG	.394 (10.01)	1/0AWG	✓			✓	✓		Bulldog	Aggressive	1.38	1.55	Ø1.02	1 (0.45)
2,000	LMG2000	04452W	✓	✓	✓	.109 (2.77)	8AWG	.594 (15.09)	4/0AWG	✓			✓	✓		Bulldog	Aggressive	1.34	1.86	1.0 x 1.5	1.5 (0.68)
5,000	LMG4500	04453W	✓	✓		.18 (4.57)	6AWG	.60 (15.24)	4/0AWG	✓			✓	✓		Parallel	Fine	4.10	3.64	1.25 x 2.0	3.6 (1.63)
5,000	LMG4500A	04478W			✓	.18 (4.57)	6AWG	.60 (15.24)	4/0AWG	✓			✓	✓		Parallel	Aggressive	4.10	3.64	1.25 x 2.0	3.6 (1.63)
5,000	LMG4501	04454W	✓	✓		.18 (4.57)	6AWG	.60 (15.24)	4/0AWG		✓		✓		✓	Parallel	Fine	4.10	3.64	1.25 x 2.0	3.7 (1.68)
5,000	LMG4501A	04499W			✓	.18 (4.57)	6AWG	.60 (15.24)	4/0AWG		✓		✓		✓	Parallel	Aggressive	4.10	3.64	1.25 x 2.0	3.7 (1.68)
5,000	LMG4502	04455W	✓	✓		.18 (4.57)	6AWG	.60 (15.24)	4/0AWG		✓	✓		✓		Parallel	Fine	4.10	3.64	1.25 x 2.0	3.7 (1.68)
5,000	LMG4503	04456W	✓	✓		.18 (4.57)	6AWG	.60 (15.24)	4/0AWG		✓	✓		✓		Parallel	Aggressive	4.10	3.64	1.25 x 2.0	3.7 (1.68)
10,000	LMG4600	04459W	✓	✓		.30 (7.62)	1AWG	.80 (20.32)	450MCM	✓			✓	✓		Parallel	Fine	5.08	5.03	1.35 x 2.25	6.7 (3.04)
10,000	LMG4600A	04479W			✓	.30 (7.62)	1AWG	.80 (20.32)	450MCM	✓			✓	✓		Parallel	Aggressive	5.08	5.03	1.35 x 2.25	6.7 (3.04)
10,000	LMG4601	04460W	✓	✓		.30 (7.62)	1AWG	.80 (20.32)	450MCM		✓		✓		✓	Parallel	Fine	5.08	5.03	1.35 x 2.25	7 (3.18)
10,000	LMG4601A	04457W			✓	.30 (7.62)	1AWG	.80 (20.32)	450MCM		✓		✓		✓	Parallel	Aggressive	5.08	5.03	1.35 x 2.25	7 (3.18)
10,000	LMG4602	04461	✓	✓		.30 (7.62)	1AWG	.80 (20.32)	450MCM		✓	✓		✓		Parallel	Fine	5.08	5.03	1.35 x 2.25	7 (3.18)
12,000	LMG4800	04471W	✓	✓		.70 (17.77)	397MCM	1.25 (32)	1130MCM	✓			✓	✓		Parallel	Fine	5.57	5.64	1.35 x 2.25	8.1 (3.67)
12,000	LMG4800A	04449W			✓	.70 (17.77)	397MCM	1.25 (32)	1130MCM	✓			✓	✓		Parallel	Aggressive	5.57	5.64	1.35 x 2.25	8.1 (3.67)
12,000	LMG4801	04472W	✓	✓		.70 (17.77)	397MCM	1.25 (32)	1130MCM		✓		✓		✓	Parallel	Fine	5.57	5.64	1.35 x 2.25	8.3 (3.76)
12,000	LMG4801A	04450W			✓	.70 (17.77)	397MCM	1.25 (32)	1130MCM		✓		✓		✓	Parallel	Aggressive	5.57	5.64	1.35 x 2.25	8.3 (3.76)
12,000	LMG4802	04473	✓	✓		.70 (17.77)	397MCM	1.25 (32)	1130MCM		✓	✓		✓		Parallel	Fine	5.57	5.64	1.35 x 2.25	8.3 (3.76)
20,000	LMG4700	04465W	✓	✓		.70 (17.77)	397MCM	1.25 (32)	1130MCM	✓			✓	✓		Parallel	Fine	7.58	7.38	2.5 x 3.6	20.6 (9.34)
20,000	LMG4701	04466W	✓	✓		.70 (17.77)	397MCM	1.25 (32)	1130MCM		✓		✓		✓	Parallel	Fine	7.58	7.38	2.5 x 3.6	21 (9.53)
20,000	LMG4702	04467W	✓	✓		.70 (17.77)	397MCM	1.25 (32)	1130MCM		✓	✓		✓		Parallel	Fine	7.58	7.38	2.5 x 3.6	21 (9.53)
20,000	LMG4900	04475W	✓	✓		1.24 (31.50)	1130MCM	1.8 (45.72)	2312MCM				✓			Parallel	Fine	11.75	11.75	2.5 x 3.45	34.4 (15.60)

* Aggressive teeth optional for grips with capacities of 5,000, 10,000 and 12,000 lbs.

WIRE TYPES

Aluminum Conductor Steel-Reinforced Cable (ACSR)

High-strength, high-capacity conductor. Providing optimal strength, the concentric-lay-stranded conductor is made from high-purity round aluminum (1350-H19) wrapped around an inner core of galvanized steel wires. This wire is an overhead conductor for carrying voltage and is used in both distribution and transmission applications.

Stranded Copper

This type of wire, used for carrying voltage, has been used less frequently over the last few years and has been replaced by ACSR. However, it is still occasionally used as an overhead conductor and also in substations.

Aluminum Conductor

Aluminum conductor wire without the steel core. Softer than ACSR. Used mostly in distribution applications.

Extra-High-Strength Cable (EHSC or EHS)

This wire is tensioned to "guy" or support poles and is the connecting wire that reinforces a side strain or dead end. It is the wire that is used to connect the top of the pole to an anchor at ground at an angle for support. The EHSC is much harder than standard guy strand wire and requires a more aggressive grip.

Messenger Guy Wire

This is a wire that is used to support other cable or conductors and is usually made of steel. The messenger guy wire provides strength so the other cables don't have to be as strong.

3 CONFIGURATIONS AVAILABLE

Little Mule wire grips are available in the 3 different configurations shown below.



Standard Model
(Spring-Loaded Gate, Un-Notched Handle)
 (Model Pictured: LMG4600)



Hot Line Model
(Spring-Loaded Gate, Notched Handle)
 (Model Pictured: LMG4601)



Hot Line Model
(Non-Spring-Loaded Gate, Un-Notched Handle)
 (Model Pictured: LMG4602)

GRIP TYPES AND FEATURES

STANDARD OR HOT LINE MODELS

Choose from standard models or hot line models.

NON-SPRING LOADED OR SPRING-LOADED GATES

Spring-loaded gates allow a lineman to use a holding stick to open the gate and place the grip on the wire. When released, the gate closes over the wire and prevents the grip from falling off the wire.

UN-NOTCHED OR NOTCHED HANDLES

Grips available with or without notched handles. The notched handle on spring-loaded models locks the grip in open position for placement on or removal from wire, then releases instantly.



CLOSED GRIP

JAW STYLES

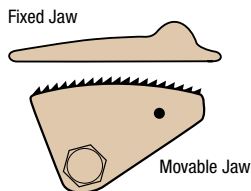

BULLDOG JAW
Standard on 1,000 and 2,000 lb. capacities.

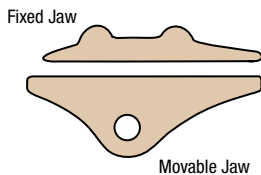

PARALLEL JAW
Standard on 5,000, 10,000, 12,000 and 20,000 lb. capacities.

OPEN s

Notch locks the grip in the open position for placement on or removal from wire, then releases instantly.

FIXED JAW TEETH STYLES



SMOOTH (NO TEETH)
All capacities



LARGE TEETH
1,000 and 2,000 lb. capacities



MOVABLE JAW TEETH STYLES



FINE TEETH
Optional on 5,000, 10,000, 12,000 and 20,000 lb. capacities

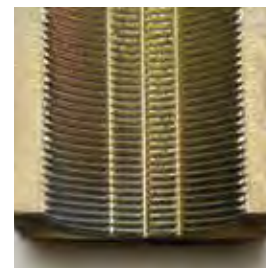

AGGRESSIVE TEETH
Optional on 5,000, 10,000 and 12,000 lb. capacities

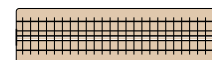

JAW PROFILES



Standard on 1,000 lb. capacities



Standard on 2,000 lb. capacities



Standard on 5,000, 12,000 and 20,000 lb. capacities

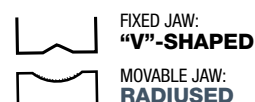

Standard on 10,000 lb. capacities

GRIP CLEANING, LUBRICATION & INSPECTION

To keep your Little Mule Wire Grips in good working condition, we recommend taking the following steps:

CLEANING & LUBRICATION:

Step 1:

Clean the surfaces of the grip jaws using a cloth or round wire brush.

Step 2:

Spray all joints and moving parts, including the jaws, with degreaser. Then, use a round wire brush to remove any dirt from the jaws.

Step 3:

Once clean, wipe the wire grips until they are dry. If grips are still dirty, repeat steps as needed.

Step 4:

Lubricate all joints and any moving parts. The surfaces of the grip jaws should not be lubricated.

INSPECTION:

To inspect the wire grip, carefully examine the condition of the jaws. Next, check that the jaws and other parts of the grip are aligned to ensure that there is no distortion. Once you've inspected the jaws, open and close the grips to check for smooth operation. Finally, check all other parts and joints for any distortion.

During the inspection, if you find that the grip is bent or distorted, it should be thrown away and replaced. It should NOT be repaired.



STRAP & CHAIN LEVER HOISTS

- 20 **HOIST COMPARISON CHART**
- 22 **LITTLE MULE LINEMAN'S STRAP HOIST**
- 36 **LSB-NC**
- 38 **COFFING G SERIES**
- 40 **CM TORNADO 360°**
- 44 **CM BANDIT**
- 46 **CM SERIES 602 & 603**

LEVER HOIST COMPARISON

When it comes to lever hoists for the utility industry, Columbus McKinnon has a variety of options depending on the application. Our product portfolio includes everything from strap hoists to chain hoists featuring link or roller chain. Each hoist is designed with features that specifically address the unique needs of utility professionals. For comprehensive look at our lever hoist offering for the utility industry, see the chart below.



PAGE 22

LITTLE MULE
LINEMAN'S
STRAP HOIST



PAGE 36

COFFING
HOISTS
G SERIES
LEVER HOIST



PAGE 36

COFFING
HOISTS
LSB-NC
RATCHET LEVER HOIST

CAPACITY (Ton)	Capacity	Reeving	Capacity	Reeving	Capacity	Reeving
1/4						
1/2	✓	1				
3/4	✓	1	✓	1	✓	1
1	✓	1 & 2			✓	1
1-1/2	✓	2	✓	2	✓	1
2	✓	2				
3	✓	2	✓	2	✓	1
4-1/2			✓	3		
6			✓	4	✓	2
9			✓	5		
11			✓	6		
13			✓	7		
15			✓	8		
FEATURES						
Load Limiter						
Metal Housing				✓		
Aluminum Housing		✓				
Free Chaining				✓		✓
Weston Brake						
Ratchet & Pawl		✓		✓		
Standard Lifts (ft.)		4.25, 5, 5.5, 7, 9, 9.25, 11, 14		5 (+/-)		5, 10, 15, 20, less chain
Zinc-Plated Chain						✓
Self-Colored Chain		N/A		✓		✓
Metric Rated						✓
Warranty		Lifetime		Lifetime		Lifetime
Country of Origin		USA		USA		USA
OPTIONS						
Bullard Hooks						
Latchlok Hooks		✓		✓		
Bronze Hooks						
Shipyards Hooks				✓		✓
Extended Lifts						✓
Chainless Heads				✓		
Zinc-Plated Chain						✓
Anchor Slings						
Radio Frequency I.D.						



PAGE 40
CM
TORNADO 360°
RATCHET LEVER HOIST



PAGE 44
CM
BANDIT
RATCHET LEVER HOIST



PAGE 46
CM
SERIES 602/603
MINI RATCHET LEVER HOISTS

CAPACITY (Ton)	Capacity	Reeving	Capacity	Reeving	Capacity	Reeving
1/4					✓	1
1/2					✓	1
3/4	✓	1	✓	1		
1						
1-1/2	✓	1	✓	1		
2						
3	✓	1	✓	1		
4-1/2						
6	✓	2	✓	2		
9	✓	3				
11						
13						
15						
FEATURES						
Load Limiter	Optional		Optional			
Metal Housing				✓		✓
Aluminum Housing	✓					
Free Chaining	✓			✓		✓
Weston Brake	✓			✓		✓
Ratchet & Pawl						
Standard Lifts (ft.)	5, 10, 15, 20		5, 10, 15, 20		5 & 10	
Zinc-Plated Chain	✓		✓		✓	
Self-Colored Chain						
Metric Rated						✓
Warranty	Lifetime		Lifetime		Lifetime	
Country of Origin	China		China		China	
OPTIONS						
Bullard Hooks						
Latchlok Hooks						
Bronze Hooks						
Shipyards Hooks	✓			✓		
Extended Lifts	✓			✓		
Chainless Heads	✓			✓		
Zinc-Plated Chain						
Anchor Slings						
Radio Frequency I.D.	✓			✓		

The Little Mule Lineman's Strap Hoist is the preferred hoist of utility industry professionals.

Single-line units available with capacities up to 1 ton.
Double-line units available with capacities up to 3 tons.

Hook configurations include:

- Standard Hooks with Safety Latches
- Hot Stick Ring Hooks with Safety Latches
- Standard Hooks with Heavy-Duty Swivel Gate Latches
- Hot Stick Ring Hooks with Hot Stick Ring Safety Latches



LEVER STRAP HOIST SPECIFICATIONS

All lever strap hoist models are designed for lifting and pulling loads up to rated capacities listed on the hoist nameplate. Features include a winding wheel for taking up slack or freestripping of the strap and a handle tip designed to bend before any mechanical part of the hoist is subject to damaging overload. The handle may be inserted into the U-frame socket from either direction to facilitate use in confined areas or to allow the operator to pull against the load under unusual conditions. A double interlocking pawl system provides positive load control at all times. Hot-stick rings on levers and hooks increase safety and utility.



LEVER STRAP HOIST OPERATION

LIFTING OR PULLING

Place reversing lever in “up” position, engaging the loading pawl against the ratchet teeth. Work handle as required to get desired lift or tension. Handle may be inserted into either end of the U-frame socket, enabling the user to work in restricted areas. Never use a cheater bar or handle other than those approved by the manufacturer.

LOWERING

Place the reversing lever in the “down” position and move the handle to its extreme down position until the load is removed from the holding pawl. As the handle is slowly released, the load will be lowered or released by one notch. To continue lowering, repeat this operation.

FREE WHEELING

The strap hoist’s torsion spring, located between the releasing arm and pawl assembly, allows for easy free wheeling. Before attempting to free wheel, make certain the strap hoist is unloaded. To release the strap for free wheeling, the reversing lever must first be in the “down” position. Press the free-wheel lever. The strap may now be stripped from the drum to facilitate more rapid positioning while attaching to the object to be pulled or lifted. For safety, the hoist will not free wheel while under load (approx. 35 lbs, depending on amount of strap on the drum).

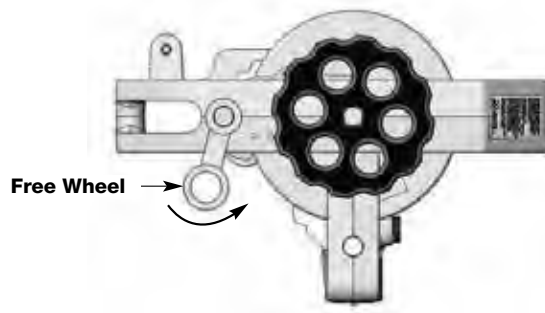
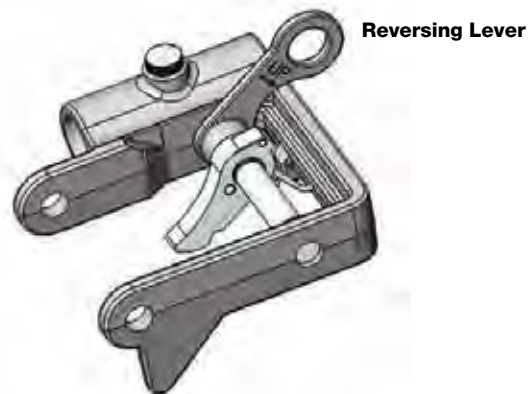



LEVER STRAP HOIST MAINTENANCE

Lever strap hoist maintenance is normally limited to cleaning and lubrication. The hoist should always be lubricated following each cleaning to replace any lubricants that were washed away.

CLEANING

Under normal use, minimal cleaning is required. Clean the metal parts and web strap with soap or detergent and water. Allow the web strap to dry thoroughly before using hoist.

STORAGE

When not using strap hoists, it is best to keep them hung up by the upper hook with the strap wound up. This will help keep the strap clean, dry and protected from accidental damage. If the strap becomes wet during use, it is best to allow the strap to dry before winding back up.

The polyester straps are seriously degraded at temperatures above 194°F. Prolonged exposure to ultraviolet light adversely affects them as well. Straps may become bleached and stiff when exposed to sunlight or arc welding. Many chemicals also have an adverse effect on polyester straps.

LEVER STRAP HOIST INSPECTION

Lever strap hoists should be inspected to prevent any accidents or failures. They are broken down into “frequent” and “periodic” inspections.

FREQUENT INSPECTIONS

In addition to performing frequent inspections, visual observations should be conducted during regular service of lever strap hoists to check for any damage. Any deficiencies shall be carefully examined and the determination made as to whether they constitute a hazard as follows:

- Check all functional operating mechanisms for maladjustment interfering with proper operation.
- Check all hooks and latches for deformation, chemical damage, cracks and wear.
- Check all hook latches for proper attachment and operation.
- Check levers for bends, cracks or other damage.
- Check for damage to the support for the hoist.

All web straps should be visually inspected by the operator or other designated person at the start of each shift. These visual observations should be focused on discovering gross damage, such as that listed below, which may be an immediate hazard:

- melting or charring
- weld splatter
- cuts or tears
- abrasive wear
- acid or caustic burns
- broken stitching
- damaged eyes
- knots or twists

LUBRICATION

- Lubricate the following areas weekly with a light grease:
 - Ratchet teeth of drum
 - Contact points between U-frame and free-wheel lever
 - Contact points between loading pawl and pin (H5230-31)
- Lubricate the following areas weekly with SAE 20-30 gear oil:
 - Rotating points of shafts, with the exception of the drum shaft
 - Hook shank
 - Only small amounts of lubricants need to be applied
 - DO NOT saturate areas with grease/oil
 - DO NOT allow lubricants to contact strap

PERIODIC INSPECTIONS

In addition to performing periodic inspections, the following should be conducted:

- A designated person shall determine whether conditions found during inspection constitute a hazard and whether disassembly is required.
- Check fasteners for evidence of loosening.
- Check web strap, suspension frame, levers, yokes, shafts, pins, rollers and locking/clamping devices for evidence of wear, corrosion, cracks and distortion.

Periodic inspections shall be performed by an appointed person. This inspection shall cover the entire length of the web strap. Special care should be taken when inspecting sections for rapid deterioration, such as the following:

- Sections in contact with saddles, equalizer sheaves or other sheaves where web strap travel is limited.
- Sections at or near ends where broken threads or cuts may be evident.
- Sections subject to reverse bends. Sections that are normally hidden during visual inspection, such as sections passing over sheaves.

LEVER STRAP HOIST INSPECTION CHECKLIST

Type of Hoist _____ Capacity (Tons) _____

Location / Crew / Truck _____ Date Placed in Service _____

Manufacturer _____ Manufacturer's Serial No. _____

Item	Normal Service (Weekly Usage)		Heavy Service (Daily Usage)		Severe Service (Daily Usage and/or in severe weather conditions)		Remarks
	Visual Monthly	Record Yearly	Visual Weekly	Record 6 Months	Visual Daily	Record Monthly	
FREQUENT INSPECTION							
All functional mechanisms for proper operation	•		•		•		
Hooks and latches for deformation, chemical damage, cracks & wear (See ASME B30.10)	•		•		•		
Hook latch operation	•		•		•		
Check web strap for melting or charring, weld splatter, cuts or tears abrasive wear, acid or caustic burns, broken stitching, damaged eyes or knots or twists.	•		•		•		
Levers for bends, cracks, etc. Hoist support for damage	•		•		•		
PERIODIC INSPECTION							
Evidence of loose pins, nuts or rivets		••		•••		•••	
Evidence of worn, corroded, cracked or distorted parts such as suspension frame, levers, web strap attachments, yokes, shafts, pins and rollers		••		•••		•••	
Evidence of damage to hook retaining nuts and pins		••		•••		•••	
Evidence of worn pawls, cams or ratchet as well as corroded, stretched or broken springs		••		•••		•••	
Warning label		••		•••		•••	
End connections and terminations of web strap		••		•••		•••	

- Visual inspection by operator or other designated personnel.
- Visual inspection by designated person of conditions.
- Visual inspection by designated person of conditions unless conditions indicate that disassembly should be done to permit detailed inspection.



HOIST SAFETY & WARNINGS

Every Little Mule Lineman's Hoist is built with performance, reliability and, most importantly, safety in mind. To ensure safe and proper use of our product, we suggest you follow and adhere to the warning and safety information below.

All Little Mule Lineman's Hoists are manufactured in compliance with our interpretation of applicable sections of American Society of Mechanical Engineers Code (ASME) B30.21.

WARNING

Improper operation of a hoist can create a potentially hazardous situation which, if not avoided, could result in death or serious injury. To avoid such a potentially hazardous situation, the operator shall:

- ▲ NOT operate a malfunctioning or unusually performing hoist.
- ▲ NOT operate the hoist until you have thoroughly read and understood the manufacturer's Operating and Maintenance Instructions or Manuals.
- ▲ NOT operate a hoist that has been modified without the manufacturer's approval or certification to be in conformity with applicable OSHA regulations.
- ▲ NOT lift or pull more than the rated load of the hoist.
- ▲ NOT use a damaged hoist or hoist that is not working properly.
- ▲ NOT use hoist with twisted, kinked, damaged, or worn strap.
- ▲ NOT operate with any handle extension (cheater bar).
- ▲ NOT attempt to "free wheel" the hoist while a load is applied.
- ▲ NOT use the hoist to lift, support or transport people.
- ▲ NOT lift loads over people and should always make sure all personnel remain clear of the supported load.
- ▲ NOT attempt to lengthen the hoist strap or repair damaged hoist strap.
- ▲ Protect the hoist's strap from weld splatter and any damaging contaminants.
- ▲ NOT operate hoist when it is restricted from forming a straight line from hook to hook in the direction of loading.
- ▲ NOT use hoist strap as a sling or wrap it around the load.
- ▲ NOT apply the load to the tip of the hook or to the hook latch.
- ▲ NOT apply load unless strap is properly seated in the drum.
- ▲ NOT apply load if bearing prevents equal loading on all load supporting chains.
- ▲ NOT operate beyond the limits of the load chain travel.
- ▲ NOT leave load supported by the hoist unattended unless specific precautions have been taken.
- ▲ NOT allow the strap hoist or hook to be used as an electrical or welding ground.
- ▲ NOT allow the strap hoist or hook to be touched by a live welding electrode.
- ▲ NOT remove or obscure the warnings on the hoist.
- ▲ NOT operate a hoist that has not been securely attached to a suitable support.
- ▲ NOT operate a hoist unless load slings or other approved attachments are properly sized and seated in the hook saddle.
- ▲ NOT lift loads that are unbalanced. Ensure the holding action is secure and take up slack carefully.
- ▲ NOT operate a hoist unless all persons are and remain clear of the supported load.
- ▲ Report malfunctions or unusual performances of a hoist after it has been shut down until repaired.
- ▲ NOT operate a hoist on which the safety placards or decals are missing or illegible.
- ▲ Be familiar with operating controls, procedures and warnings.

CAUTION

Improper operation of a hoist can create a potentially hazardous situation which, if not avoided, could result in minor or moderate injury. To avoid such a potentially hazardous situation, the operator shall:

- ▲ Maintain a firm footing or be otherwise secured when operating the hoist.
- ▲ Check ratchet and pawl function by tensioning the hoist prior to each lift or pulling operation.
- ▲ Use hook latches. Latches are to retain slings, chains, etc. under slack conditions only.
- ▲ Make sure the hook latches are closed and not supporting any part of the load.
- ▲ Make sure the load is free to move and will clear all obstructions.
- ▲ Avoid swinging the load or hook.
- ▲ Avoid lever "fly-back" by keeping a firm grip on the lever until operating stroke is completed and the lever is at rest.
- ▲ Inspect the hoist regularly, replace damaged or worn parts and keep appropriate records of maintenance.
- ▲ Use the hoist manufacturer's recommended parts when repairing the unit.
- ▲ NOT use the hoist load limiting or warning device to measure load.
- ▲ NOT operate except with manual power.
- ▲ NOT permit more than one operator to pull on lever at the same time. More than one operator is likely to cause hoist overload.
- ▲ NOT allow your attention to be diverted from operating the hoist.
- ▲ NOT allow the hoist to be subjected to sharp contact with other hoists, structures or objects through misuse.
- ▲ NOT adjust or repair the hoist unless qualified to perform such adjustments or repairs.

LEVER STRAP HOIST SAFETY INFORMATION

The web strap on the Little Mule Lineman's hoist is NOT a rated insulating member. When clean and dry, the strap may have dielectric properties typical of nylon or polyester fibers. The non-metallic handle and webbing provide an extra measure of safety for use around energized power lines.

Use an appropriate insulating member in conjunction with the hoist to achieve proper working distances per OSHA Regulation Subpart V, 1926.950 or your company work practices.

When the handle swings closer to energized conductors than OSHA safe working distances or company practices permit, use appropriate clothing and rubber gloves for rated voltages.



WARNING

ELECTRICAL SHOCK
MAY RESULT IN SERIOUS
INJURY OR DEATH



LEVER STRAP HOIST FEATURES

HOT STICK RING →

Hooks styles available include:

- Standard Hook with Safety Latch
- Hot Stick Ring Hook with Safety Latch
- Standard Hook with Heavy-Duty Swivel Gate Latch
- Hot Stick Ring Hook with Hot Stick Ring Safety Latch

CAST ALUMINUM FRAME →

HANDLE ATTACHMENT THUMBSCREW →

HANDLE TIP →

INSULATED FIBERGLASS HANDLE →

RUBBER HANDLE GRIP ←

ALUMINUM HOT STICK RING ←

NON-CONDUCTIVE WINDING WHEEL ←

POLYESTER WEB STRAP ←

QUICK-DISCONNECT DESIGN ←

FORGED STEEL HOOKS WITH 360° ROTATION ←

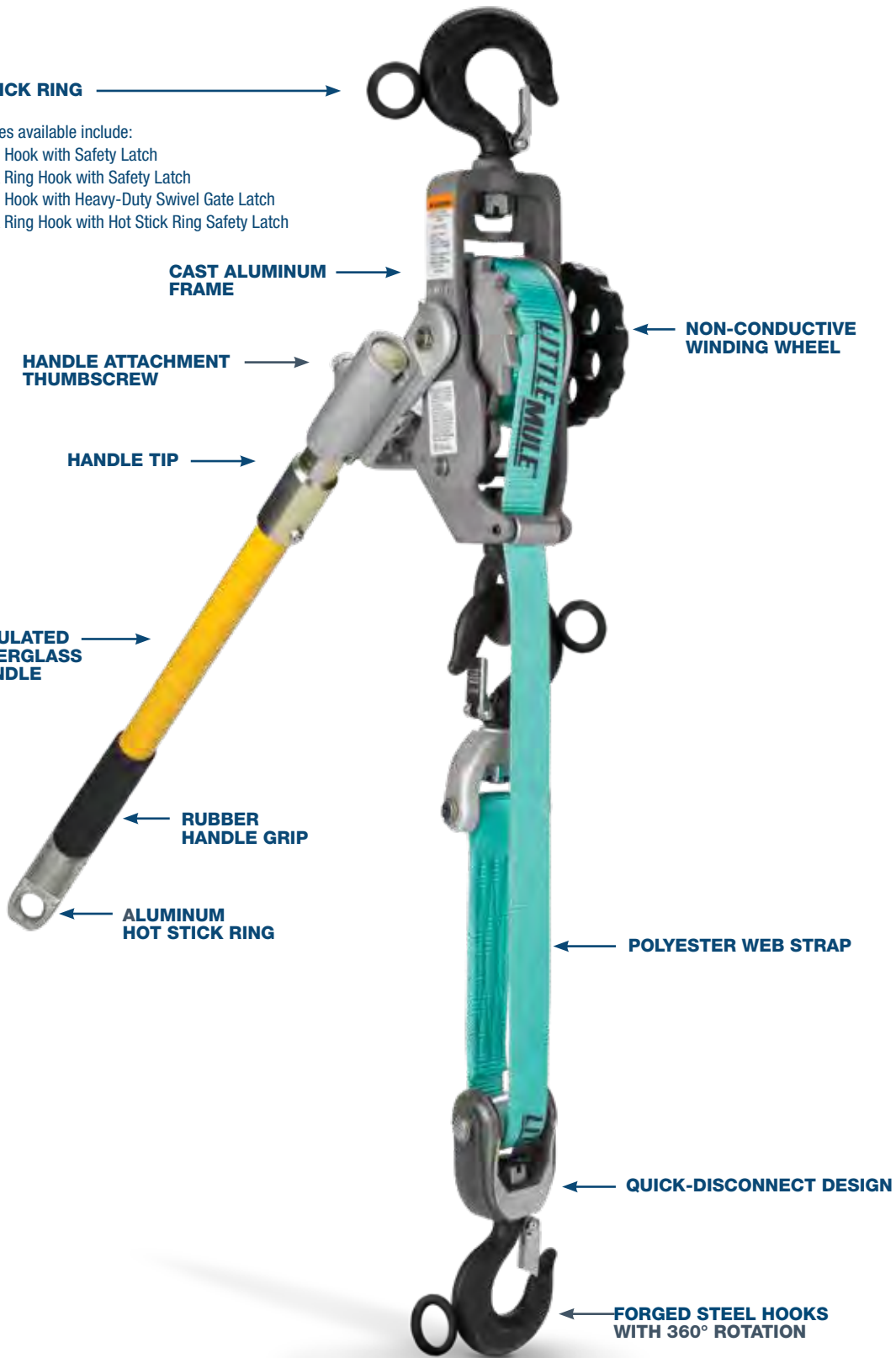

ABOUT THE WEB STRAPS ON THE LINEMAN'S HOIST

The straps on the Little Mule Lineman's Hoists are made from a durable webbing-woven polyester. They are woven and sewn in the U.S.A. Polyester webbing has less stretch than nylon and has no reduction in strength when wet.

FOR WEB STRAP INSPECTION AND MAINTENANCE INFORMATION, SEE PAGE 24.

WEB STRAP COLOR IDENTIFICATION

Use the chart below to identify the proper strap for your Little Mule Lineman's Hoist.

Product Code	Strap Material	Strap Color	For Strap Hoist Model Capacity (tons)*	Strap Length (ft.)	Strap Width (in.)
371/10	Polyester	Green	1/2 & 3/4 (single line) 1 & 1-1/2 (double line)	10	1-1/4
3471/15	Polyester	Yellow	3/4 (single line) 1-1/2 (double line)	15	1-1/2
372/12	Polyester	Blue	1 (single line) 2 (double line)	12	1-1/2
RLC19	Polyester	Green	3 (double line)	12	2

* Capacity ratings apply to the hoist when used in conjunction with the strap.



LINEMAN'S STRAP HOIST

CAPACITIES

1/2 to 3 tons

LIFTS

Up to 14 ft.

SPECIFICATIONS

• Aluminum Housing • Double Pawls

The Little Mule Lineman's Strap Hoist is high quality and dependable, making it one of the favorites of linemen across the nation. This strap hoist is designed for rugged use with dependability in mind.

FEATURES & BENEFITS

NON-CONDUCTIVE HANDLE

Fiberglass handle with polyester webbing provides added non-conductive material when using proper hot line handling techniques. Some models also available with hot stick ring on handle.

OVERLOAD FEATURE

Solid fiberglass handle, with replaceable tips, bends to alert operator of a possible overload.

HOOKS AND GATE LATCHES

All hooks swivel 360° and are equipped with latches. Optional hooks with gates can also be added.

POSITIVE LOAD HOLDING

Double interlocking pawls assure one pawl is engaged at all times. Dual pawl springs provide unsurpassed reliability.

SAFE DESIGN

Thumbscrews used to secure the handle are pegged and cannot be backed out. Competitive units use butterfly nuts which can cause the handle to come loose.

OPEN DESIGN

The open design allows for easy inspection and cleaning.

LIGHTWEIGHT AND RUGGED

These hoists are made with cast aluminum frames as well as corrosion-resistant stainless steel springs and frame shafts. Roller shafts are stainless steel plated. All rotating shafts are mounted on bronze bushings for reduced wear.

HOOK OPTIONS

- Standard Hook With Safety Latch
- Hot Stick Ring Hook With Safety Latch
- Standard Hook With Heavy-Duty Swivel Gate Latch
- Hot Stick Ring Hook With Hot Stick Ring Safety Latch

EASY LOAD POSITIONING

Utilizing a double pawl system, this multiple pawl stops for precise load adjustment.

EASY TO OPERATE

Self-storing web drum provides compact operation. Non-conductive winding wheel provided for quick take-up or positioning of slack webbing.

4:1 DESIGN FACTOR

Meets or exceeds minimum 4:1 design factor and all requirements of ASME/ANSI Standard B-30.21. All units tested at 125% of rated load.

ADJUSTABLE CAPACITY HOIST OPTION

Double-reeved hook block configuration increases capacity. Easily removable sheave block with a quick disconnect design allows the hoist to be converted for double or single-line use.

LIFETIME WARRANTY



MODEL 344C
1 ton Capacity
with Standard
Hooks &
Safety Latches

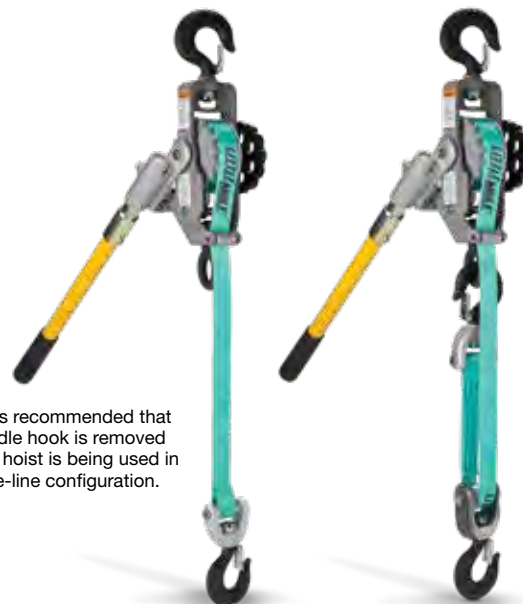

Note: it is recommended that the middle hook is removed when the hoist is being used in a single-line configuration.

SINGLE-LINE CONFIGURATION
Model 300A

DOUBLE-LINE CONFIGURATION
Model 300A

SPECIFICATIONS

Model Number	Product Code	Single Line			Double Line			Web Strap Color	Web Strap Width (in.)	Web Strap Length (ft.)	Handle Length (in.)	Net Weight (lbs.)	Replacement Part Model Numbers				
		Capacity (tons)	Lift (ft.)	Head-room (in.)	Capacity (tons)	Lift (ft.)	Head-room (in.)						Web Strap	Fiberglass Handle	Fiberglass Handle with Hot Stick Ring	Steel Handle Tip (Overload Protection)	Hook & Latch
Standard Hooks with Safety Latches																	
250A	04190W	1/2	9	21	1	4.25	25	Green	1-1/4	10	20	11	371/10	2050B	2050DB	350K	3M003C01S
300A	04141W	3/4	9	21	1-1/2	4.25	25	Green	1-1/4	10	20	11	371/10	2050B	2050DB	350K	3M003C01S
322C	04480WC	3/4	14	20	1-1/2	7	23	Yellow	1-1/2	15	24	11.5	3471/15	2450B	2450DB	350K	3M003C01S
344C	04490WC	1	11	20	2	5.5	23	Blue	1-1/2	12	30	12.5	372/12	3050B	3050DB	350K	3M004C09S
6000A	04181W	N/A			3	5	27	Green	2	12	30	25.5	RLC19	2050B	2050DB	350K	3K10S
Hot Stick Ring Hooks with Safety Latches																	
250DA	04191W	1/2	9.25	18	1	4.25	25	Green	1-1/4	10	20	11.5	371/10	2050B	2050DB	350K	3M003C02S
300DA	04142W	3/4	9.25	18	1-1/2	4.25	25	Green	1-1/4	10	20	11.5	371/10	2050B	2050DB	350K	3M003C02S
322DC*	04481WC	3/4	14	20	1-1/2	7	23	Yellow	1-1/2	15	24	11.5	3471/15	2450B	2450DB	350K	3M003C02S
344DC	04491WC	1	11	20	2	5.5	23	Blue	1-1/2	12	30	13	372/12	3050B	3050DB	350K	3M004C02S
6000DA*	04182W	N/A			3	5	27	Green	2	12	30	25.5	RLC19	2050B	2050DB	350 5 6	Top: 3M007C05S Bottom: 3M007C06S
Standard Hooks with Heavy Duty Swivel Gate Latches																	
250CA	04192W	1/2	9	21	1	4.25	25	Green	1-1/4	10	20	11	371/10	2050B	2050DB	350K	14L1
300CA	04143W	3/4	9	21	1-1/2	4.25	25	Green	1-1/4	10	20	11	371/10	2050B	2050DB	350K	14L1
322CC*	04482WC	3/4	14	23	1-1/2	7	27	Yellow	1-1/2	15	24	11.5	3471/15	2450B	-	350K	324PGH1
344CC*	04492WC	1	11	23	2	5.5	27	Blue	1-1/2	12	30	12.5	372/12	3050B	-	350K	324PGH1
6000CA*	04183W	N/A			3	5	29	Green	2	12	30	12.5	RLC19	2050B	2050DB	350 5 6	Top: 3M005A03S Bottom: 3M005A02SB
Hot Stick Ring Hooks with Hot Stick Ring Safety Latches																	
250DHA*	04193W	1/2	9.25	18	1	4.25	25	Green	1-1/4	10	20	11.5	371/10	2050B	2050DB	350K	324DH
300DHA*	04144W	3/4	9.25	18	1-1/2	4.25	25	Green	1-1/4	10	20	11.5	371/10	2050B	2050DB	350K	324DH
322DHC*	04483WC	3/4	14	22	1-1/2	7	26	Yellow	1-1/2	15	24	11.5	3471/15	2450B	2450DB	350K	Hook: 3M003C03 Latch: 324DH9
344DHC*	04493WC	1	11	22	2	5.5	26	Blue	1-1/2	12	30	13	372/12	2050B	3050DB	350K	Hook: 3M004C06 Latch: 324DH10

* Includes Hot Stick Rings on all hooks and control surfaces and quick disconnect shaft.

Little Mule Lineman's Strap Hoists and Cable Hoists are made in the USA in accordance with ASME B30.21 Standard for Manually Lever Operated Hoists and can be used for lifting, pulling and tensioning applications. (Note: Hoists should not be used to lift people or lift loads over people.)

HOOK OPTIONS

Little Mule Strap Hoists are available with 4 hook configurations:



STANDARD HOOK WITH SAFETY LATCH

Forged steel hooks provide lasting strength and durability. Hooks will bend open under extreme overload situations. Latches are standard.

(Suffix: A/C)



HOT STICK RING HOOK WITH SAFETY LATCH

Hot stick hooks have a welded ring for use with holding sticks. Latches are standard.

(Suffix: DA/DC)



STANDARD HOOK WITH HEAVY-DUTY SWIVEL GATE LATCH

Bullard-type, swivel gate latch provides positive locking action for secure load holding in all environments.

(Suffix: CA/CC)



HOT STICK RING HOOK WITH HOT STICK RING SAFETY LATCH

Hot stick gate latch models have rings on the latch and the hook for use on energized lines. Holding sticks can easily maneuver the latch and hooks.

(Suffix: DHA/DHC)

HANDLE OPTIONS



STANDARD HANDLE

Solid fiberglass, non-conductive handle (standard).



HANDLE WITH HOT STICK RING

Solid fiberglass, non-conductive handle with aluminum hot stick ring.



MODEL 250A

1 ton Capacity
Standard Hooks & Safety Latches
(Double-Line Configuration Shown)

HOOK OPTIONS:

- Hot Stick Ring Hook
- with Safety Latch (250DA)
- Standard Hook with Heavy-Duty Swivel Gate with Latch (250CA)
- Hot Stick Ring Hook with Hot Stick Ring Hook Safety Latch (250DHA)

HANDLE OPTIONS:

- Standard Handle
- Handle with Hot Stick Ring



MODEL 300A

1-1/2 ton Capacity
Standard Hooks & Safety Latches
(Double-Line Configuration Shown)

HOOK OPTIONS:

- Hot Stick Ring Hook
- with Safety Latch (3000DA)
- Standard Hook with Heavy-Duty Swivel Gate with Latch (300CA)
- Hot Stick Ring Hook with Hot Stick Ring Hook Safety Latch (300DHA)

HANDLE OPTIONS:

- Standard Handle
- Handle with Hot Stick Ring

**MODEL 322C**

1-1/2 Ton Capacity
Standard Hooks & Safety Latches
(Double-Line Configuration Shown)

HOOK OPTIONS:

- Hot Stick Ring Hook with Safety Latch (322DC)
- Standard Hook with Heavy-Duty Swivel Gate Latch (322CC)
- Hot Stick Ring Hook with Hot Stick Ring Safety Latch (322DHC)

HANDLE OPTIONS:

- Standard Handle
- Handle with Hot Stick Ring

**MODEL 344C**

2 Ton Capacity
Standard Hooks & Safety Latches
(Double-Line Configuration Shown)

HOOK OPTIONS:

- Hot Stick Ring Hook with Safety Latch (344DC)
- Standard Hook with Heavy-Duty Swivel Gate Latch (344CC)
- Hot Stick Ring Hook with Hot Stick Ring Safety Latch (344DHC)

HANDLE OPTIONS:

- Standard Handle
- Handle with Hot Stick Ring

**MODEL 6000A**

3 ton Capacity
Standard Hooks & Safety Latches
(Double-Line Configuration Shown)

HOOK OPTIONS:

- Hot Stick Ring Hook with Safety Latch (6000DA)
- Standard Hook with Heavy-Duty Swivel Gate Latch (6000CA)

HANDLE OPTIONS:

- Standard Handle
- Handle with Hot Stick Ring

FIRST IN SAFETY

The Little Mule Lineman's Strap Hoist features an industry-leading solid fiberglass handle with overload protection, designed to keep the operator safe.



HANDLE TIP WITH OVERLOAD PROTECTION

This special steel tube is designed to bend in an overload situation instead of suddenly snapping or breaking. This acts as a visual indicator to the operator that the hoist is overloaded. Replacement handle tips are available and can be replaced in the field. Several competitive units have an aluminum tip that can snap when overloaded. The sudden shock can cause a wrist, shoulder, elbow or other type of injury to the operator.

SOLID FIBERGLASS HANDLE

The non-conductive handle is made of solid fiberglass, making it more durable and less susceptible to breaking or shattering. Competitive units use a fiberglass handle with a foam core, increasing the likelihood of the handle breaking or shattering when the hoist is overloaded.

NON-SLIP GRIP

The durable rubber grip allows the operator to get a firm grip, even while wearing gloves.

HOT STICK RING

Handles are available with an aluminum hot stick ring for hot line models.



SECURE HANDLE ATTACHMENT TO HOIST

The handle is secured to the hoist's body with a pegged thumbscrew that cannot be backed out. Competitive units use a butterfly nut that can accidentally loosen or fall off, causing the handle to detach.

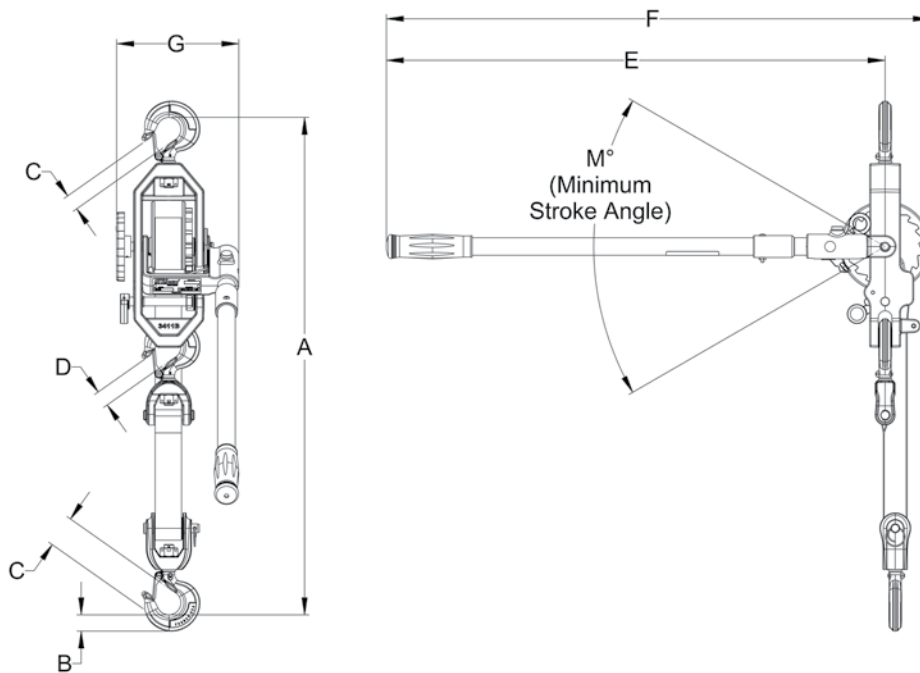

DIMENSIONS

Model Number	Product Code	Single Line		Double Line		Dimensions (in.)								
		Capacity (tons)	Lift (ft.)	Capacity (tons)	Lift (ft.)	A (Single Line)	A (Double Line)	B	C	D	E	F	G	M°
Standard Hooks with Safety Latches														
250A	04190W	1/2	9	1	4.5	17.0	25.0	0.94	0.88	0.88	21.4	23.5	6.0	22°
300A	04141W	3/4	9	1-1/2	4.5	17.0	25.0	0.94	0.88	0.88	21.4	23.5	6.0	22°
322C	04480WC	3/4	14	1-1/2	7.0	18.3	23.3	0.94	0.88	0.88	25.8	28.4	6.9	22°
344C	04490WC	1	11	2	5.5	19.5	29.5	1.04	1.02	0.88	31.8	34.4	6.9	22°
6000A	04181W	N/A		3	5.0	-	27.3	1.44	1.30	-	25.3	28.0	8.7	36°
Hot Stick Ring Hooks with Safety Latches														
250DA	04191W	1/2	9	1	4.5	17.0	25.0	0.94	0.88	0.88	22.8	24.8	6.0	22°
300DA	04142W	3/4	9	1-1/2	4.5	17.0	25.0	0.94	0.88	0.88	22.8	24.8	6.0	22°
322DC*	04481WC	3/4	14	1-1/2	7.0	18.3	23.3	0.94	0.88	0.88	27.2	29.8	6.9	22°
344DC	04491WC	1	11	2	5.5	19.5	29.5	1.04	1.02	0.88	33.2	35.8	6.9	22°
6000DA*	04182W	N/A		3	5.0	-	27.3	1.44	1.30	-	26.7	29.5	8.7	36°
Standard Hooks with Heavy Duty Swivel Gate Latches														
250CA	04192W	1/2	9	1	4.5	19.6	28.9	1.04	1.13	1.13	21.4	23.5	6.0	22°
300CA	04143W	3/4	9	1-1/2	4.5	19.6	28.9	1.04	1.13	1.13	21.4	23.5	6.0	22°
322CC*	04482WC	3/4	14	1-1/2	7.0	20.9	27.2	1.04	1.13	1.13	25.8	28.4	6.9	22°
344CC*	04492WC	1	11	2	5.5	21.7	33.0	1.04	1.13	1.13	31.8	34.4	6.9	22°
6000CA*	04183W	N/A		3	5.0	-	28.9	1.34	1.37	-	25.3	28.0	8.7	36°
Hot Stick Ring Hooks with Hot Stick Ring Safety Latches														
250DHA*	04193W	1/2	9	1	4.5	18.3	27.0	0.94	0.88	0.88	22.8	24.8	6.0	22°
300DHA*	04144W	3/4	9	1-1/2	4.5	18.3	27.0	0.94	0.88	0.88	22.8	24.8	6.0	22°
322DHC*	04483WC	3/4	14	1-1/2	7.0	19.6	25.3	0.94	0.88	0.88	27.2	29.8	6.9	22°
344DHC*	04493WC	1	11	2	5.5	20.8	31.4	1.04	1.02	0.88	33.2	35.8	6.9	22°

* Includes Hot Stick Rings on all hooks and control surfaces and quick disconnect shaft.

Little Mule Lineman's Strap Hoists and Cable Hoists are made in the USA in accordance with ASME B30.21 Standard for Manually Lever Operated Hoists and can be used for lifting, pulling, and tensioning applications. (Note: Hoists should not be used to lift people or lift loads over people.)

LSB-NC RATCHET LEVER HOIST

CAPACITIES

3/4 to 6 tons

LIFTS

Up to 20 ft.
(longer lifts are available)

SPECIFICATIONS

- Lifetime Warranty

Built on proven technology and decades of engineering expertise, the Coffing LSB-NC is designed for safety, strength, and reliable performance - and it's made in the USA with domestic and imported parts at our facility in Wadesboro, NC. With American-made hooks, chain, and other key components, as well as a stamped-steel housing, these ratchet lever hoists are lightweight and durable, making them ideal for construction and commercial applications.

FEATURES & BENEFITS

MADE IN THE USA WITH AMERICAN AND IMPORTED PARTS

Hoist is made in the USA in Wadeboro, NC, with domestic and imported parts. Features American-made hooks and chain, manufactured by Columbus McKinnon, along with additional imported and domestic components.

COMPACT, LIGHTWEIGHT DESIGN

The LSB-NC hoist portfolio features a short handle that is ideal for use in applications with space constraints. Hoist is also lightweight and easy to transport from job to job.

LOW PULL FORCE

Simple, low-effort operation. Double-reduction gearing and a short, cushioned-grip handle ensure ease of use with minimal handle effort.

EASY FREE CHAINING

A state-of-the-art freewheeling mechanism allows for quick and easy one-handed take up and positioning of slack chain. Designed not to accidentally free chain while under load.

BUILT FOR SAFETY AND DURABILITY

- Powder-coated finish provides protection against corrosion.
- Stamped steel housing withstands impact and rugged use.
- For added safety, the LSB-NC includes American-made hooks featuring a forked latch that helps ensure positive engagement of the hook tip with the latch.
- Plated, American-made chain provides strength and longer chain life.

POSITIVE LOAD CONTROL

Enclosed screw-and-disc type load brake stays clean and dry for positive load positioning. Latches on hooks provide positive load engagement.

360° ROTATING HANDLE

The rotating handle provides versatile rigging options when used in confined spaces and enables near effortless operation.

OPTIONAL SHIPYARD HOOKS

Available on 1, 1-1/2, and 3-ton units.



SPECIFICATIONS

Capacity Tons (kgs)	Product Number	Lift ft (m)*	Reeving	Min Distance between hooks in. (mm)	Handle Length in. (mm)	Average Handle Effort lbs. (kgs)	Net Weight** lbs. (kgs)
3/4 (750)	LSB07505NC	5	1	11.73 (298)	9.84 (250)	53 (24)	13.59 (6.17)
	LSB07510NC	10	1	11.73 (298)	9.84 (250)	53 (24)	15.84 (7.19)
	LSB07515NC	15	1	11.73 (298)	9.84 (250)	53 (24)	18.09 (8.21)
	LSB07520NC	20	1	11.73 (298)	9.84 (250)	53 (24)	20.34 (9.23)
	LSB075NCLCX	Less Chain	1	11.73 (298)	9.84 (250)	53 (24)	11.46 (5.20)
1 (1000)	LSB10005NC	5	1	12.40 (315)	10.51 (267)	51 (23)	20.01 (9.08)
	LSB10010NC	10	1	12.40 (315)	10.51 (267)	51 (23)	23.01 (10.48)
	LSB10015NC	15	1	12.40 (315)	10.51 (267)	51 (23)	26.01 (11.78)
	LSB10020NC	20	1	12.40 (315)	10.51 (267)	51 (23)	29.01 (13.18)
	LSB100NCLCX	Less Chain	1	12.40 (315)	10.51 (267)	51 (23)	17.63 (8.00)
1-1/2 (1500)	LSB15005NC	5	1	13.94 (354)	10.51 (267)	77 (35)	20.34 (9.23)
	LSB15010NC	10	1	13.94 (354)	10.51 (267)	77 (35)	23.78 (10.79)
	LSB15015NC	15	1	13.94 (354)	10.51 (267)	77 (35)	27.29 (12.38)
	LSB15020NC	20	1	13.94 (354)	10.51 (267)	77 (35)	30.79 (13.97)
	LSB150NCLCX	Less Chain	1	13.94 (354)	10.51 (267)	77 (35)	17.63 (8.00)
3 (3000)	LSB30005NC	5	1	16.46 (418)	14.80 (376)	87 (39)	38.98 (17.68)
	LSB30010NC	10	1	16.46 (418)	14.80 (376)	87 (39)	46.10 (20.91)
	LSB30015NC	15	1	16.46 (418)	14.80 (376)	87 (39)	52.81 (23.95)
	LSB30020NC	20	1	16.46 (418)	14.80 (376)	87 (39)	67.81 (30.76)
	LSB300NCLCX	Less Chain	1	16.46 (418)	14.80 (376)	87 (39)	32.62 (14.80)
6 (6000)	LSB60005NC	5	2	21.34 (542)	14.80 (376)	92 (42)	65.95 (29.92)
	LSB60010NC	10	2	21.34 (542)	14.80 (376)	92 (42)	80.17 (36.37)
	LSB60015NC	15	2	21.34 (542)	14.80 (376)	92 (42)	94.39 (42.82)
	LSB60020NC	20	2	21.34 (542)	14.80 (376)	92 (42)	108.61 (49.27)
	LSB600NCLCX	Less Chain	2	21.34 (542)	14.80 (376)	92 (42)	54.66 (24.79)

* Standard lifts shown. Consult factory for other available lifts.

** Net weight with standard chain

G SERIES RATCHET LEVER HOIST

CAPACITIES	LIFTS	SPECIFICATIONS
3/4 to 15 tons	Up to 60 in.	• Lifetime Warranty

Coffing G Series ratchet lever hoists are efficient and durable, featuring malleable iron roller chain. Roller chain, often referred to as bicycle chain, can be spliced to create longer lifts and can handle higher capacities than coil chain. G Series hoists are ideal for utility transmission and distribution work.

FEATURES & BENEFITS

CAPACITIES & LIFT

Rated loads from 3/4 to 15 tons. For standard lifts, see chart below. Other lifts available.

RUGGED

Unit and handle made from malleable iron. Riveted construction makes the unit tamper resistant.

FREE CHAINING

Free-chaining mechanism allows quick and easy take-up and positioning of slack chain. Hoist will not free chain when under load.

HANDLE STOPS

Prevent handle from spinning if it is accidentally released by the operator.

OPTIONS

- Bullard Hooks
- Bronze Hooks
- Zinc-Plated Hooks (consult factory)

SINGLE OR DOUBLE LOCKING RATCHET AND PAWL DESIGN PROVIDES MULTIPLE RIGGING OPTIONS

Hoist can lift, pull or bind. Can be operated from either side and will work in any position with equal efficiency.

SNAP HOOK AND LINK

Allows operator to convert unit to the next smallest capacity to provide longer lift and faster operation. Snap hook acts as an end stop and will not pass through the chain sprocket.

ADJUSTABLE LIFT

The lift/reach can be adjusted by adding or removing links.



Snap Hook

SPECIFICATIONS

Capacity		Model Number †	Standard Lift (in.)	Strands of Load Chain	Minimum Distance Between Hooks (in.)	Handle Length (in.)	Minimum Increment (in.) †	Average Handle Effort (lbs.)	Net Weight (lbs.)
(lbs.)	(kg.)								
1500	3/4	AG/AGI	56-1/2	1	13	18-3/4	.624/.313	56	14
3000	1-1/2	ATG/ATGI	57	2	15	18-3/4	.313/.156	60	17
3000	1-1/2	FG/FGI	56-1/2	1	16	27-5/8	1.0/.5	116	25
6000	3	FTG/FTGI	57	2	17-5/8	27-5/8	.50/.25	120	34
9000	4-1/2	ZG-41/2	53	3	25	33-5/8	0.3333	124	49
12000	6	ZG-6	53	4	25	33-5/8	0.25	124	59
18000	9	WG-9	60	5	30	33-5/8	0.2	124	120
22000	11	WG-11	60	6	30	33-5/8	0.167	124	130
26000	13	WG13	60	7	30	33-5/8	0.143	124	140
30000	15	WG-15	60	8	30	33-5/8	0.125	124	150

† First designation is single-pawl model and second "I" designation is double-pawl model.

Note: For complete dimensional data, refer to Coffing Dimensional Databook.

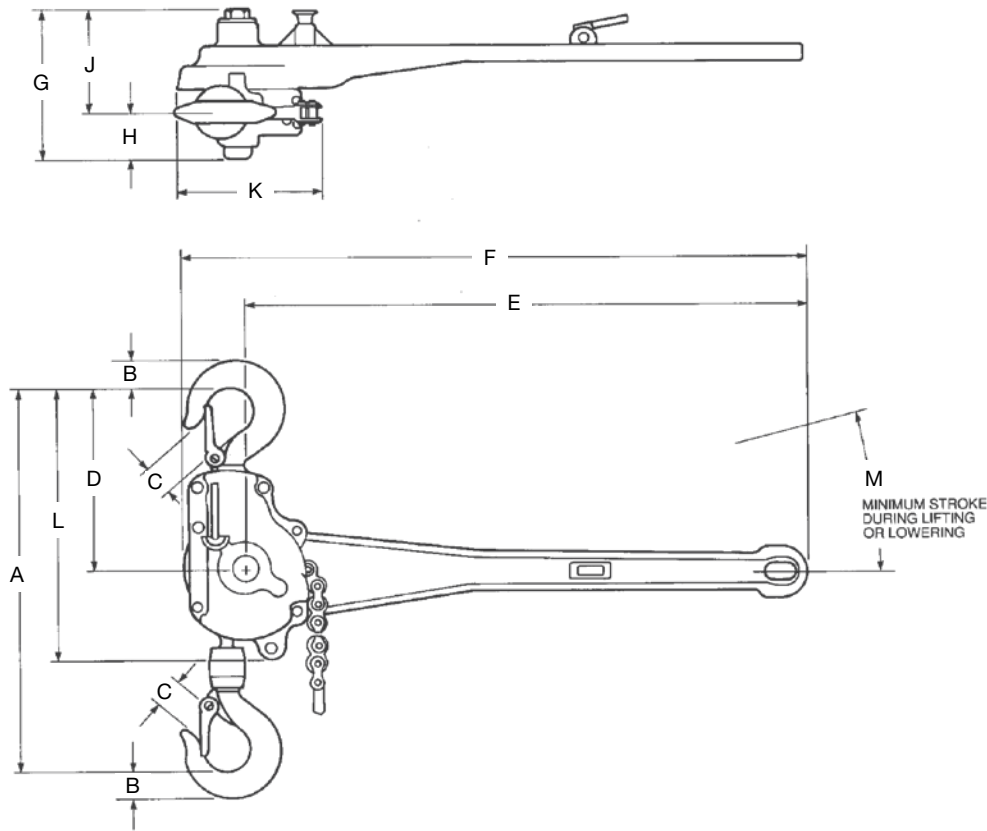

DIMENSIONS

Model Number	Capacity (lbs.)	Standard Lift (in.)	Dimensions (in.)											M
			A	B	C*	D	E	F	G	H	J	K	L	
AG/AGI ¹	1,500	56-1/2	13	1	1	6-1/4	18-3/4	20-3/4	5	1-1/2	3-1/2	4-1/2	9-1/4	AG=60°, AGI=30°
ATG ² /ATGI ^{1,2}	3,000	57	15	1	1	6-1/4	18-3/4	20-3/4	5	1-1/2	3-1/2	4-1/2	9-1/4	ATG=60°, ATGI=30°
FG/FGI ¹	3,000	56-1/2	16	1-1/8	1-1/8	7	27-5/8	29-7/8	6-1/4	1-3/4	4-1/2	5-3/4	10 1/4	FG=60°, FGI=30°
FTG ³ /FTGI ^{1,3}	6,000	57	17-5/8	1-1/8	1-1/8	7-3/8	27-5/8	29-7/8	6-1/4	1-3/4	4-1/2	5-3/4	10-5/8	FTG=60°, FTGI=30°
ZG-41/2 ⁴	9,000	53	25	1-13/16	1-11/16	8-1/4	33-5/8	36-1/8	6-1/8	1-11/16	4-7/16	6-1/8	12-7/8	60°
ZG-6 ⁵	12,000	53	25	1-13/16	1-11/16	8-1/4	33-5/8	36-1/8	6-1/8	1-11/16	4-7/16	6-1/8	12-7/8	60°
WG-9	18,000	60	30	2-1/8	1-5/8	9-1/8	33-5/8	41-3/8	6-3/8	1-3/4	4-5/8	13-1/2	14-5/8	60°
WG-11	22,000	60	30	2-1/8	1-5/8	9-1/8	33-5/8	41-3/8	6-3/8	1-3/4	4-5/8	13-1/2	14-5/8	60°
WG13	26,000	60	30	2-1/8	1-5/8	9-1/8	33-5/8	41-3/8	6-3/8	1-3/4	4-5/8	13-1/2	14-5/8	60°
WG-15	30,000	60	30	2-1/8	1-5/8	9-1/8	33-5/8	41-3/8	6-3/8	1-3/4	4-5/8	13-1/2	14-5/8	60°

¹ Double Pawls — can be operated with half strokes of lever when using in close quarters.

² Convertible model — 1 chain 3/4 ton, 112" lift. 2 chains 1-1/2 tons, 57" lift.

³ Convertible model — 1 chain 1-1/2 tons, 112" lift. 2 chains 3 tons, 57" lift.

⁴ Convertible model — 2 chain 3 tons, 76" lift. 3 chains 4-1/2 tons, 51" lift.

⁵ Convertible model — 3 chain 4-1/2 tons, 70" lift. 4 chains 6 tons, 53" lift.

All dimensions are in inches unless otherwise indicated.

** Minimum stroke on double-locking pawl models (AGI, ATGI, FGI, FTGI) is one-half (30°) that of single-locking pawl models (AG, ATG, FG, FTG).



TORNADO 360°™ RATCHET LEVER HOIST

CAPACITIES

3/4 to 9 tons

LIFTS

Up to 20 ft.
(longer lifts are available)

SPECIFICATIONS

• Metric Rated

Redefining lever-operated hoists, the CM® Tornado 360°™ features the revolutionary Sidewinder™ lever handle that allows for efficient operation in both lifting and pulling applications. Ergonomically designed for increased safety, the patent-pending CM Tornado 360° lets the operator work up to 12 times faster and with as much as 30% less pull force than with conventional ratchet lever tools.

FEATURES & BENEFITS

SIDEWINDER LEVER HANDLE

This first-of-its-kind lever handle design will revolutionize the ratchet lever hoist industry. Its unique foldable handle and 360° rotating lever increases productivity while reducing the risk of operator injury.

CONVENIENT DIRECTIONAL INDICATOR

Easy-to-use, highly visible directional indicator located on the handle clearly shows the operating direction as lifting, lowering or neutral.

EASY & SMOOTH FREE CHAINING

For quick take up and positioning of slack chain – even with one hand. Designed not to accidentally free chain while under load. Cast chain end stop allows the user to easily position the chain in free-chaining mode and prevents it from entering the liftwheel and jamming the hoist.

POSITIVE LOAD CONTROL

Enclosed Weston-type brake stays clean and dry for precise load positioning.

BUILT TO LAST

Lightweight aluminum housing withstands rigorous use and features high-quality, long-lasting bearings. Powder-coat finish provides extra protection in harsh environments.

MEETS ASME B30.21

EXCELLENT CORROSION PROTECTION

Robust chain guide and chain stripper made from cast steel and zinc plated for corrosion protection.

100% LOAD TESTED ZINC-PLATED CHAIN

Protects against corrosion.

EASY-TO-INSPECT SWIVEL HOOKS

Bolt-on hooks with nylon locks help users comply with ASME B30.21 and B30.10 inspection requirements. Hooks are forged, allowing them to yield under overload without breaking. Cast safety latches provide positive and secure load engagement.

INDUSTRY-LEADING WARRANTY

Our lifetime warranty on all mechanical components, including the Sidewinder lever handle, is the industry's best warranty against manufacturing and material defects.

With our 3-year brake warranty, if the brake discs wear out within 3 years from the date of purchase, CMCO will replace the ratchet disc assembly free of charge.

EASY IDENTIFICATION

Each unit has a unique serial number for easy and accurate identification.



OPTIONS

SHIPYARD HOOKS

Available on 1-1/2 and 3 ton units only.

INTERNAL LOAD LIMITER

Allows the handle to rotate freely, preventing the lifting of an overload sufficient to damage the hoist. Units equipped with a load limiter feature a black hand wheel for quick and easy on-site identification.



DIMENSIONS & SPECIFICATIONS

Capacity/Tons (kg)	Product Code		Standard Lift ft. (m)	Pull Force to Lift Rated Load lbf. (kgf.)		Reeving	Weight lbs. (kg)	Dimensions in. (mm)																													
	without load limiter	with load limiter		Sidewinder Lever Handle Operation	Traditional Lever Operation			A (Min)	B	C	D	E	F	G	H	J	K	L	M	N	O	P															
0.75 (750)	TOR07505	TOR07505LL	5 (1.5)	38.2 (17.3)	47.2 (21.4)	1	14.7 (6.7)	12.60 (320)	0.79 (20)	1.06 (27)	0.71 (18)	12.87 (327)	11.81 (300)	1.57 (40)	3.19 (81)	4.76 (121)	2.20 (56)	4.13 (105)	6.33 (161)	1.18 (30)	4.72 (120)	10.1 (257)															
	TOR07510	TOR07510LL	10 (3.0)				16.8 (7.6)																														
	TOR07515	TOR07515LL	15 (4.5)				18.9 (8.6)																														
	TOR07520	TOR07520LL	20 (6.0)				21 (9.5)																														
	TOR075LCX	TOR075LCXLL	Less Chain				12.3 (5.6)																														
1.5 (1,500)	TOR15005	TOR15005LL	5 (1.5)	58.5 (26.5)	60.7 (27.5)	1	21.1 (9.6)	14.76 (375)	1.02 (26)	1.22 (31)	0.83 (21)	12.87 (327)	11.81 (300)	2.01 (51)	3.78 (96)	5.79 (147)	2.71 (69)	4.33 (110)	7.05 (179)	1.18 (30)	4.72 (120)	10.7 (273)															
	TOR15010	TOR15010LL	10 (3.0)				24.6 (11.2)																														
	TOR15015	TOR15015LL	15 (4.5)				28.2 (12.8)																														
	TOR15020	TOR15020LL	20 (6.0)				31.7 (14.4)																														
	TOR150LCX	TOR150LCXLL	Less Chain				17 (7.7)																														
	00002145		Optional Upper Shipyard Hook				4.4 (2.0)																14.02 (356)	1.10 (28)	1.06 (27)	0.91 (23)	12.87 (327)	11.81 (300)	1.46 (37)	3.78 (96)	5.24 (133)	2.72 (69)	4.33 (110)	7.05 (179)	1.18 (30)	4.72 (120)	10.75 (273)
	3315WLP		Optional Lower Shipyard Hook				2.87 (1.3)																														
3 (3,000)	TOR30005	TOR30005LL	5 (1.5)	79.4 (36)	90.4 (41)	1	38 (17.2)	17.52 (445)	1.46 (37)	1.57 (40)	1.10 (28)	14.84 (377)	13.78 (350)	2.24 (57)	4.84 (123)	7.09 (180)	3.39 (86)	4.76 (121)	8.15 (207)	1.18 (30)	4.72 (120)	11.77 (299)															
	TOR30010	TOR30010LL	10 (3.0)				45.4 (20.6)																														
	TOR30015	TOR30015LL	15 (4.5)				52.7 (23.9)																														
	TOR30020	TOR30020LL	20 (6.0)				60.1 (27.3)																														
	TOR300LCX	TOR300LCXLL	Less Chain				29.2 (13.2)																														
	00002383		Optional Upper Shipyard Hook				4.23 (1.92)																17.17 (436)	1.46 (37)	1.42 (36)	1.10 (28)	14.84 (377)	13.78 (350)	1.89 (48)	4.84 (123)	6.73 (171)	3.39 (86)	4.76 (121)	8.15 (207)	1.18 (30)	4.72 (120)	11.77 (299)
3403WLP		Optional Lower Shipyard Hook	4.81 (2.18)																																		
6 (6,000)	TOR60005	TOR60005LL	5 (1.5)	83.8 (38)	92.6 (42)	2	63.7 (28.9)	22.17 (563)	1.77 (45)	1.73 (44)	1.38 (35)	14.84 (377)	13.78 (350)	2.80 (71)	6.38 (162)	9.17 (233)	3.39 (86)	4.76 (121)	8.15 (207)	1.18 (30)	4.72 (120)	11.77 (299)															
	TOR60010	TOR60010LL	10 (3.0)				78.4 (35.6)																														
	TOR60015	TOR60015LL	15 (4.5)				93.1 (42.2)																														
	TOR60020	TOR60020LL	20 (6.0)				107.8 (48.9)																														
	TOR600LCX	TOR600LCXLL	Less Chain				45 (20.4)																														
9 (9,000)	TOR90005	TOR90005LL	5 (1.5)	94 (42.6)	112.9 (51.2)	3	109.1 (49.5)	27.36 (695)	2.67 (68)	2.67 (68)	1.96 (50)	14.84 (377)	13.78 (350)	4.56 (116)	7.83 (199)	12.40 (315)	3.39 (86)	4.76 (121)	8.15 (207)	1.18 (30)	4.72 (120)	11.77 (299)															
	TOR90010	TOR90010LL	10 (3.0)				131.1 (59.5)																														
	TOR90015	TOR90015LL	15 (4.5)				153.2 (69.5)																														
	TOR90020	TOR90020LL	20 (6.0)				175.2 (79.5)																														
	TOR900LCX	TOR900LCXLL	Less Chain				82.6 (37.5)																														

3/4, 1-1/2 AND 3 TON UNITS

6 TON UNITS

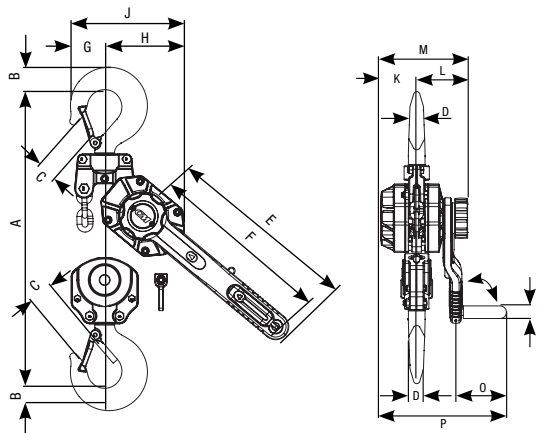
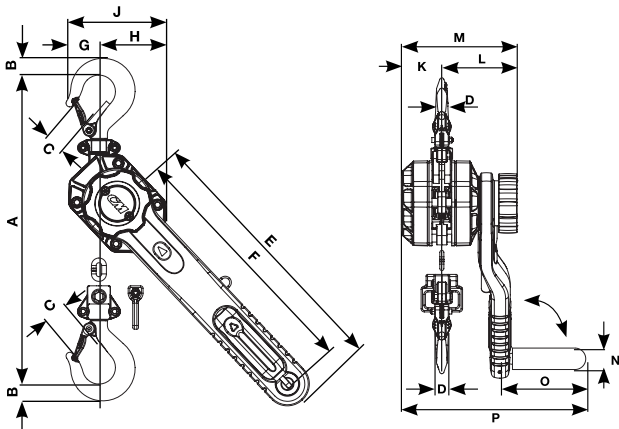

9 TON UNITS

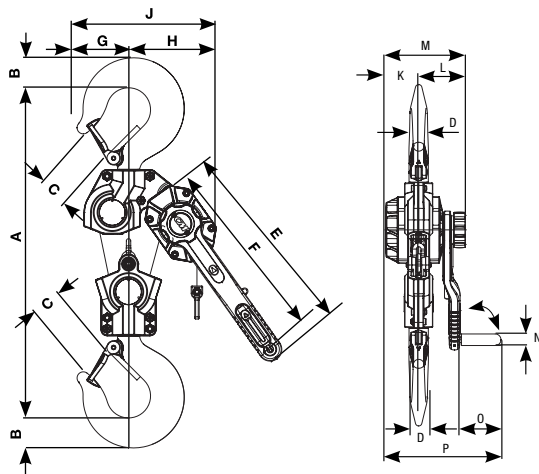

ZINC-PLATED BULK CHAIN & CHAIN DRUM

Product Code	Description	Weight lbs. (kg)
T56Z	Bulk Chain (per foot) for 3/4 ton units	.42 (.19)
635221D500	Chain Drum (500 ft.) for 3/4 ton units	224 (101)
85961ZFT	Bulk Chain (per foot) for 1-1/2 ton units	.708 (.32)
85961ZD500	Chain Drum (500 ft.) for 1-1/2 ton units	354 (160.6)
85394	Bulk Chain (per foot) for 3 & 6 ton units	1.471 (.66)
85394D500	Chain Drum (500 ft.) for 3 & 6 ton units	735.5 (333.6)
85339	Bulk Chain (per foot) for 9 ton units	1.471 (.66)
85339D500	Chain Drum (500 ft.) for 9 ton units	735.5 (333.62)



▶ LEVER HOISTS

THE PATENT-PENDING CM TORNADO 360° RATCHET LEVER HOIST FEATURES THE REVOLUTIONARY SIDEWINDER LEVER HANDLE.

What makes the Sidewinder unique are two innovative components:

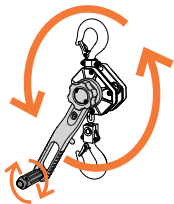

1. 360° ROTATING LEVER

The unique offset, or curved, design of the lever keeps the operator's hand and body aligned with the load chain. This reduces the risk of the twist effect (when a hoist twists around the chain) and the need to stabilize the hoist with another hand.

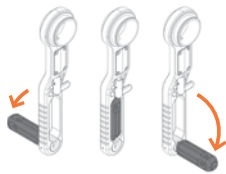

2. FOLD-OUT REVOLVING HANDLE

Recessed in the lever, the heavy-duty steel core handle folds down into position on either side of the lever, allowing for easy operation from any angle. The handle is grooved to provide a secure grip – even with gloves.

The handle revolves, allowing the operator to ergonomically and easily maintain control of the lever through its full 360° range of motion.



Together, the Sidewinder's lever and handle allow the operator to realize the full potential of 360° rotation, making the CM Tornado 360° unlike any other ratchet lever hoist on the market.

DISTINCTIVE CLICKING SOUND
ENSURES THE HANDLE IS LOCKED INTO POSITION

To return handle to upright position, simply pull the handle outward and snap into place inside the lever.



EASILY CHANGE YOUR GRIP TO SUIT THE APPLICATION

When an application requires a customary ratcheting hand grip, the Tornado 360° can be operated like a traditional lever tool when the lever handle is in the upright position.

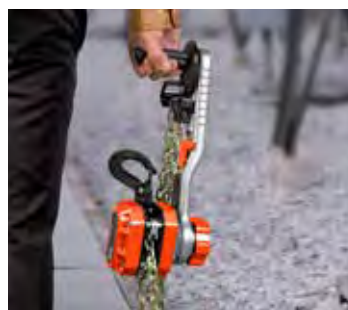

EASILY CARRY & TRANSPORT WITH JUST ONE HAND

When folded out, the lever handle can serve as a carrying grip for easy transport. Simply attach the end stop to the hook and slip the hook onto the Sidewinder lever handle to lift and carry the unit with one hand.



ERGONOMIC DESIGN DELIVERS OPTIMAL OPERATOR SAFETY

Hoist design allows the operator to work in a safe and ergonomic position. Sidewinder lever handle enables smooth 360° operation, reducing repetitive wrist action experienced with traditional ratchet lever hoists.

Double reduction gearing and high-quality bearings decrease required pull force by up to 30%, reducing operator fatigue.





BANDIT™ RATCHET LEVER HOIST

CAPACITIES

3/4 to 6 tons

LIFTS

Up to 20 ft.
(longer lifts are available)

SPECIFICATIONS

• Metric Rated

The CM® Bandit™ is one of the most compact and durable ratchet lever hoists in the industry. Its lightweight and portable design, easy free-chaining feature and 360° rotating handle make it one of the most versatile hoists on the market today. Available in 3/4, 1-1/2, 3 and 6 ton capacities for all of your pulling and lifting needs.

FEATURES & BENEFITS

COMPACT & PORTABLE DESIGN

Rugged, yet lightweight, design and construction allow the Bandit to be easily transported and used in even the most confined spaces.

FREE-CHAINING

Easy free-chaining feature allows for quick take up and positioning of slack chain. Designed not to accidentally free chain while under load.

360° ROTATING HANDLE

Full rotation of handle allows for versatile rigging options when working in tight spaces.

LOW HANDLE EFFORT

Double reduction gearing provides easy operation with minimal handle effort.

COMFORT-FIT HANDLE

Screwed-on comfortable rubber grip makes for a secure hold in all environments.

LOAD SECURITY & EASY INSPECTION

Upper and lower hooks feature standard cast safety latches that provide positive and secure load engagement. Hooks are bolted on for easy removal and inspection.

MEETS ASME B30.21 POSITIVE LOAD CONTROL

Enclosed Weston-type load brake stays clean and dry for positive load positioning.

EASY TO POSITION & ATTACH

Upper and lower hooks feature extra-wide throat openings to allow for easier attachment to pick points. Hooks swivel 360° for faster positioning.

BUILT TO LAST

Impact-resistant stamped steel housing withstands repeated rigorous use.

CORROSION RESISTANT

Standard powder-coat finish on housing and zinc plating on major components for extra protection against corrosion when working in harsh environments.

100% LOAD TESTED ZINC-PLATED CHAIN

Protects against corrosion.

EASY IDENTIFICATION

Each unit has a unique serial number for easy and accurate identification.

OPTIONAL SHIPYARD HOOKS

Shipyards hooks are available as an option on 1-1/2 & 3 ton units.

OPTIONAL GOLD CHROMATE CHAIN

Designed and manufactured in the U.S.A. by Columbus McKinnon. Protects against corrosion.

OPTIONAL INTERNAL LOAD LIMITER

Allows the handle to rotate but will not lift if load exceeds 125% of the working load limit.

SHIPS IN 3 DAYS – GUARANTEED

3/4 & 1-1/2 ton units are eligible for our In-Stock Guarantee.

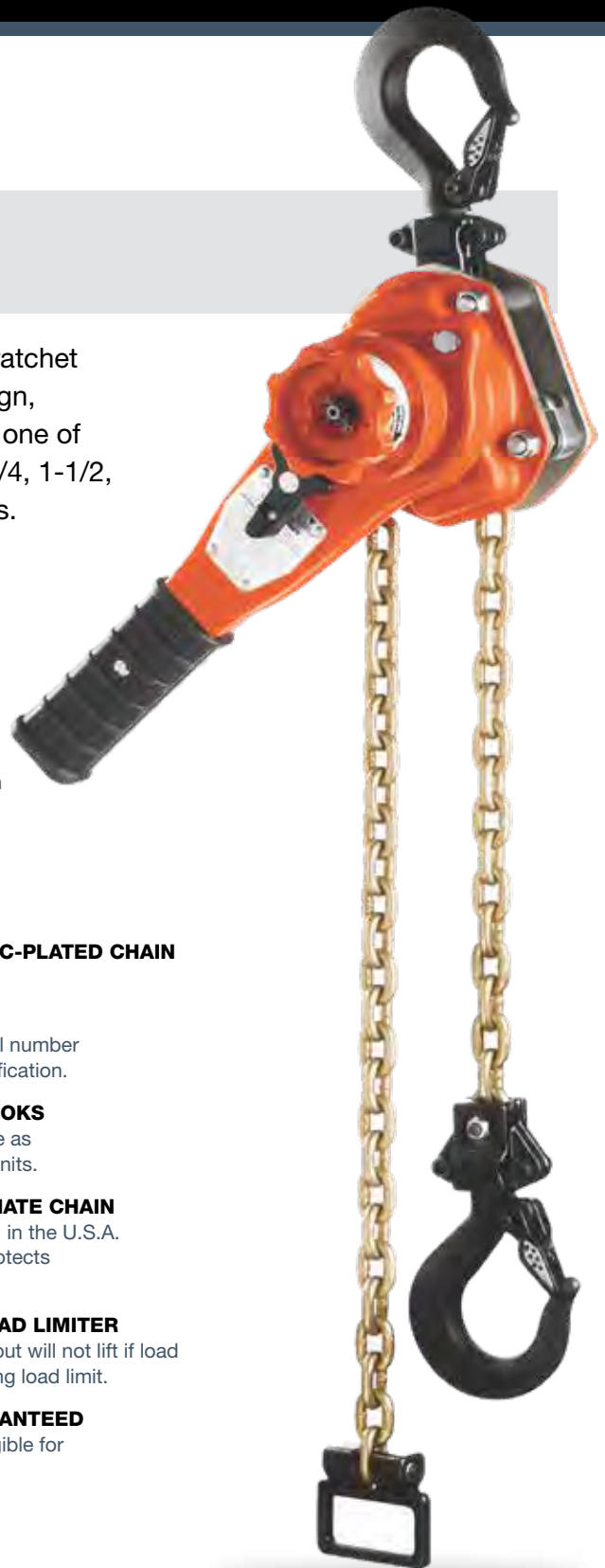

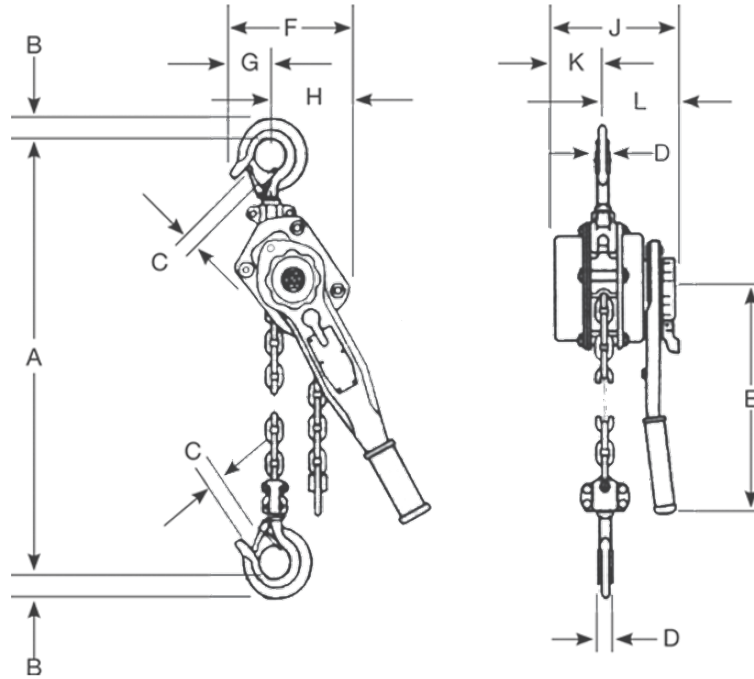

SPECIFICATIONS

Model Number	Capacity Metric Rated Ton (kg)	Standard Lift ft. (m)	Lever Pull to Lift Rated Load lbs./ft. (kg)	Weight lbs. (kg)	Dimensions in. (mm)										
					A	B	C	D	E	F	G	H	J	K	L
BAN07505	3/4 (750)	5 (1.52)	45 (20.41)	13.6 (6.17)	12.80 (325.12)	0.94 (23.88)	1.13 (28.70)	0.69 (17.53)	9.63 (244.60)	4.88 (123.95)	2.19 (55.63)	3.31 (84.07)	6.06 (153.92)	2.11 (53.59)	3.95 (100.33)
BAN07510		10 (3.05)		15.7 (7.12)											
BAN07515		15 (4.57)		18 (8.16)											
BAN07520		20 (6.1)		20.1 (9.12)											
BAN15005	1-1/2 (1500)	5 (1.52)	64 (29.03)	20.7 (9.39)	14.20 (360.68)	1.13 (28.70)	1.25 (31.75)	0.81 (20.57)	10.25 (260.35)	5.63 (143.00)	2.38 (60.45)	3.56 (90.42)	6.75 (171.45)	2.69 (68.33)	4.13 (104.90)
BAN15010		10 (3.05)		24.3 (11.02)											
BAN15015		15 (4.57)		27.9 (12.65)											
BAN15020		20 (6.1)		31.5 (14.29)											
BAN30005	3 (3000)	5 (1.52)	73 (33.11)	38.3 (17.37)	17.50 (444.5)	1.69 (42.93)	1.56 (39.62)	1.25 (31.75)	16.37 (415.8)	7.52 (191.01)	3.38 (85.85)	4.65 (118.11)	7.84 (199.14)	3.29 (83.57)	4.56 (115.82)
BAN30010		10 (3.05)		45.7 (20.73)											
BAN30015		15 (4.57)		53 (24.04)											
BAN30020		20 (6.1)		60.4 (27.4)											
BAN60005	6 (6000)	5 (1.52)	93 (42.18)	63.2 (28.67)	22.00 (558.8)	1.81 (45.97)	2.19 (55.63)	1.50 (38.1)	16.37 (415.8)	9.47 (240.54)	3.38 (85.85)	6.05 (153.67)	7.84 (199.14)	3.29 (83.57)	4.56 (115.82)
BAN60010		10 (3.05)		77.9 (35.33)											
BAN60015		15 (4.57)		92.6 (42.00)											
BAN60020		20 (6.1)		107.3 (48.7)											

Check for availability on 3 and 6 ton units.



SERIES 602™ & 603™ MINI RATCHET LEVER HOISTS

CAPACITIES

550 to 1,100 lbs.

LIFTS

Standard Lifts of 5 & 10 ft.

SPECIFICATIONS

- Weston Brake
- Lifetime Warranty
- Plated Chain

The CM® Series 602™ and Series 603™ mini ratchet lever hoists are the most compact ratchet lever hoists on the market. With capacities up to 1,100 pounds, these lightweight and portable hoists operate just like larger lever hoists. The Series 602 and 603 can easily fit in a tool box, allowing you to carry these handy hoists to and from projects.

FEATURES & BENEFITS

EASY TO USE

Great for use in confined areas, even with one-handed operation. Rubber hand grip for better comfort and security.

EASY & SMOOTH FREE CHAINING

Easily position the chain and quickly attach it to the load. Designed not to accidentally free chain while under load.

POSITIVE LOAD CONTROL

Enclosed Weston-type brake stays clean and dry for precise load positioning.

EXCELLENT CORROSION PROTECTION

Powder-coat finish provides extra protection in harsh environments.

BUILT TO LAST

Steel frame, gear case and cover withstand rigorous use.

PLATED LOAD CHAIN

Hardened, link-type alloy steel load chain is zinc plated on the Series 602 and gold chromate on the Series 603 for protection against corrosion.

EASY-TO-INSPECT SWIVEL HOOKS

Upper and lower hooks are forged, allowing them to yield under overload without breaking. Cast safety latches provide positive and secure load engagement.

METRIC RATED

INDUSTRY-LEADING WARRANTY

Our lifetime warranty on all mechanical components is the industry's best warranty against manufacturing and material defects.



Series 603
1,100 lb.
Capacity

Series 602
550 lb.
Capacity

OPTIONS

- Convenient Carrying Bag



Series 602
Carrying Bag



Series 603
Carrying Bag

The CM® Series 602™ and Series 603™ mini ratchet lever hoists are ideal for pulling fiber optic, phone and other types of wire through underground conduit where there is not a lot of tension on the wire.

SPECIFICATIONS

Product Code	Model Number	Rated Capacity		Standard Lift (ft.)	Number of Chainfalls	Minimum Distance Between Hooks (in.)	Lift w/One Full Lever Turn (in.)	Handle Length (in.)	Handle Pull @ W.L.L. (lbs.)	Weight (lbs.)
		(lbs.)	(Kg.)							
0210	Series 602	550	250	5	1	9.45	3.15	6.300	56	6.0
0214	Series 602	550	250	10	1	-	-	-	-	7.0
0212	Series 602 Carry Bag	-	-	-	-	-	-	-	-	0.3
0215	Series 603	1,100	500	5	1	11.125	1.57	6.375	78	7.0
0216	Series 603	1,100	500	10	1	11.125	1.57	6.375	78	8.0
0217	Series 603 Carry Bag	-	-	-	-	-	-	-	-	0.3



SERIES 602

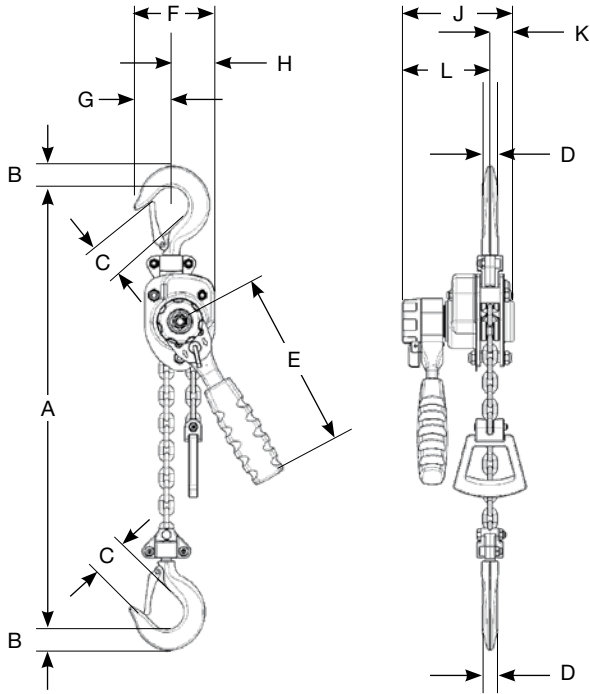

SERIES 603

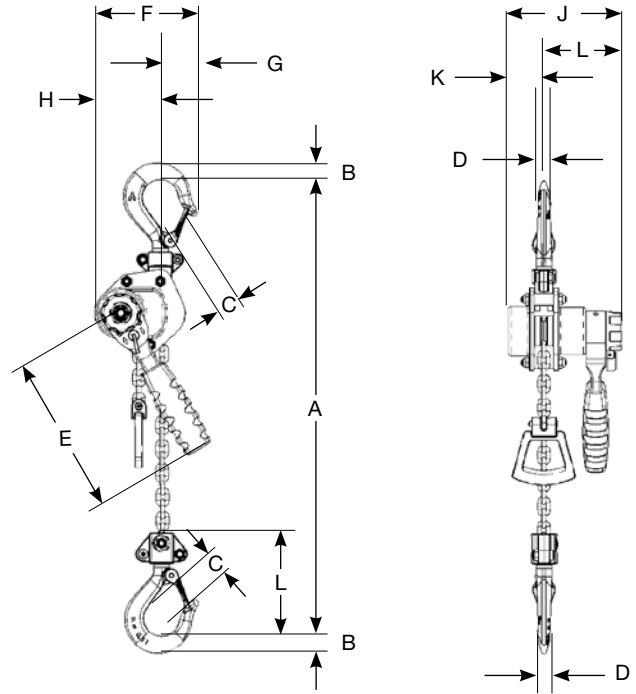

DIMENSIONS

Product Code	Model Number	Capacity (lbs.)	Standard Lift (ft.)	Dimensions (in.)										
				A	B	C	D	E	F	G	H	J	K	L
0210	Series 602	550	5	9.45	0.790	0.83	0.55	6.300	2.840	1.30	1.500	3.86	0.830	-
0214	Series 602	550	10	9.45	0.790	0.83	0.55	6.300	2.840	1.30	1.500	3.86	0.830	-
0215	Series 603	1,100	5	11.25	0.625	1.00	0.50	6.375	4.125	1.50	2.625	4.50	1.375	4.3125
0216	Series 603	1,100	10	11.25	0.625	1.00	0.50	6.375	4.125	1.50	2.625	4.50	1.375	4.3125



Our compact mini hoists operate just like larger ratchet lever hoists, but they're small enough to fit in the palm of your hand.





BATTERY-POWERED HOIST

50 CM® BATTERYSTAR™



BATTERYSTAR™ BATTERY POWERED CHAIN HOIST

CAPACITIES

1 metric ton

LIFTS

20 ft. standard
(Optional lifts to 60 ft.)

SPECIFICATIONS

• Lift Speed: 8 feet per minute

Do you need the portability of a manual hoist without the time consuming effort of manual operation? The CM BatteryStar battery-powered chain hoist gives you that portability combined with the strength and speed of a powered chain hoist. Powered by an M18™ Red Lithium Battery from Milwaukee Tool®, the BatteryStar is built for heavy-duty lifting and uses the same M18™ battery you may already have on your job site for added convenience. Whether you need to lift components up a pole or move debris after a storm, the BatteryStar can get the job done.

FEATURES AND BENEFITS



NO ELECTRIC POWER REQUIRED

Operates on battery power, specifically a Milwaukee Tool® brand M18™ battery, making it ideal for temporary applications or areas of a facility or job site where electricity is unavailable or difficult to reach.

Provides lifting speeds up to 8 FPM, helping increase operator efficiency as much as 4x compared to using a manual hoist. Hoist also helps reduce operator effort and fatigue as compared to using a lever or hand chain hoist.



PORTABILITY

Weighing less than 50 lbs. when 20 feet of chain is included, the BatteryStar is compact and lightweight for easy portability within a facility or to a job site.

Optional road/carrying cases available. Contact us for details.

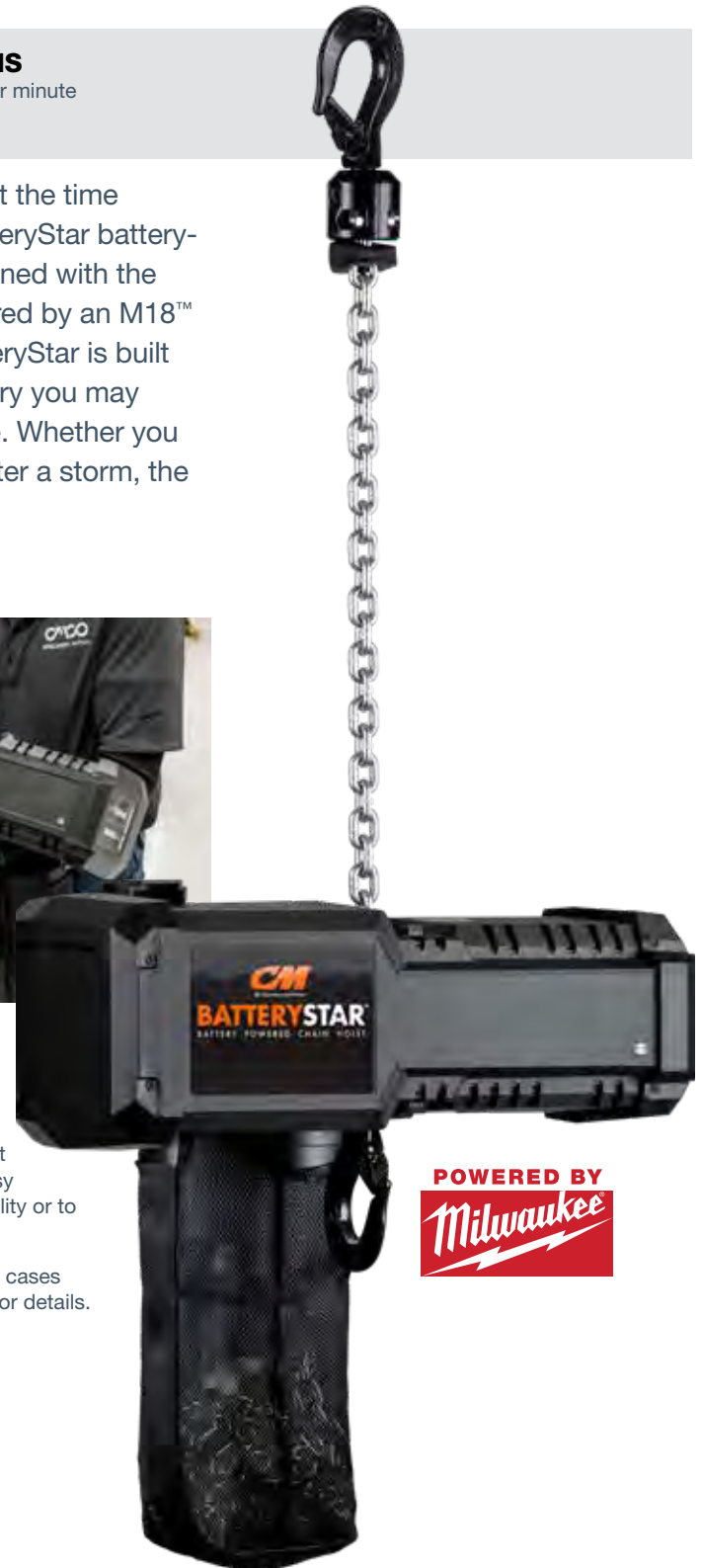

FEATURES AND BENEFITS



VERSATILE OPERATION

Hoist can be used in either typical mounting orientation with the hoist body attached to the anchor point or inverted.

Inverted operation eliminates the need to carry the weight of the hoist up to the anchor point. Just carry the hook up to the anchor point and let the hoist lift itself and the load up.

QUICK & EASY INSTALLATION

Lightweight and portable, the BatteryStar can be easily attached to an anchor point, then you're ready to lift. No cords or power is required.

Simply snap a charged battery into place, and the hoist is ready to operate.



PATENT-PENDING BRAKE

With a patent-pending design, the mechanical brake automatically applies itself when lowering the load, providing controlled descent and positioning.

Brake inspection windows on the top and bottom of the hoist allow operators to easily check brake wear, helping to facilitate preventative maintenance.



DURABILITY & RELIABILITY

Electronic clutch and secondary mechanical clutch provide dual protection from hoist overload.

Integrated limit switch for the highest and lowest hook position considerably extends the service life of the slip clutch, motor and gearbox.

Electronics are IP55 rated.

PRECISE LIFTING

Hoist offers true variable speed, allowing for precise lifting in any application.



LONG HOIST & CHAIN LIFE

Rugged composite hoist cover designed for durability in rough conditions.

Brushless DC motor for extended hoist life.

Zinc-plated load chain for protection against corrosion. Long Hoist & Chain Life

Rugged composite hoist cover designed for durability in rough conditions.

Brushless DC motor for extended hoist life.

Zinc-plated load chain for protection against corrosion.



SAFE, REMOTE OPERATION

Remote buttons allow for true variable speed – the further you push the button, the faster the lifting speed. This allows the operator to precisely position the load.

Wireless remote keeps the operator safe and away from the load, allowing for operation from over 60 ft. away from the hoist.

Remote features built-in intelligence, alerting the operator with light-up icons if the hoist is overcapacity, low battery, or hoist inspection is due.* See image above.

Rugged and durable, the remote is IP55 rated and can stand up to the harsh conditions of any worksite.

Remote is easy to connect. Features a light to show that connection is in progress, and the hoist makes an audible sound when connection is complete.

Standard stop button easily disables the remote.

Remote includes a lanyard to prevent the operator from dropping it during operation and a belt clip for easy portability.

RF-certified.

OTHER FEATURES:

5-year hoist warranty from Columbus McKinnon. 3-year battery warranty from Milwaukee Tool®.

FEM 1Cm rated. Third-party certified to UL and CSA requirements.

Chain bag provided as standard.



► BATTERY POWERED HOIST

FEATURES AND BENEFITS

TRUSTED, HIGH-QUALITY BATTERY

Supplied battery is fully compatible with more than 250 Milwaukee Tool® products utilizing M18™ batteries for added convenience on the job site.

Unique patented designs protect every REDLITHIUM™ Battery, safeguarding your investment through drops, weather exposure, and harsh environments.

Hoist includes Milwaukee Tool® ONE-KEY™* that allows you to:

- Connect your hoist and other smart tools to your job site for easy asset management and tracking.
- Access to equipment information from your computer or smartphone with an easy-to-use app and interface.
- Inspection interval feature to set reminders and store records of hoist inspections.

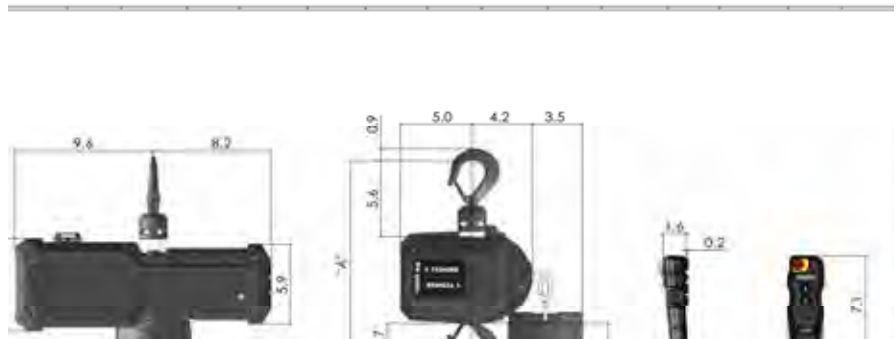

If the battery runs out during hoist operation, the load can be manually lowered. Simply open the end compartment and use a screwdriver or power drill to lower the load.

HOOK TRAVEL DISTANCE BY LOAD CAPACITY

Battery	Load (tonnes)	*Hook Travel (ft.)
12.0 Ah Battery	1/4	480
	1/2	300
	3/4	220
	1	180

*Estimated total travel with equal lifting and lowering

*Hoist inspection light is based on the recommended annual hoist inspection for normal use. Refer to the operator's manual for inspection recommendations by application. Hoist inspection indication requires the use of ONE-KEY™

SPECIFICATIONS

Product Number	Capacity	Hoist Speed (FPM)	Suspension Type	Lift (ft)*	Battery/Charger Included
BCC1008R201US	1 metric ton (1000kg)	8	Rigid Latch Type	20 ft	Yes
BCC1008R202US	1 metric ton (1000kg)	8	Rigid Latch Type	20 ft	No
BCC1008S201US	1 metric ton (1000kg)	8	Swivel Latch Type	20 ft	Yes
BCC1008S202US	1 metric ton (1000kg)	8	Swivel Latch Type	20 ft	No



*Can be ordered in 1 ft increments using BCC1008 configured code



Hook Type	Dimension "A" (inches)
RIGID	14.6
SWIVEL	15.8





UTILITY ACCESSORIES

- 48 CANT HOOKS
- 49 PEAVIES
- 50 PIKE POLES
- 51 LIFTING TONGS

CANT HOOKS

Made from the highest quality materials, Dixie cant hooks are used to move, roll, slide or float logs or poles into position. With the blunt end up against a log or pole, the hook grabs it at a second location. Once engaged, the handle gives the operator leverage to reposition it. These tools are great for right-of-way clearing and for positioning utility poles.

FEATURES & BENEFITS

HIGH-QUALITY MATERIALS AND CRAFTSMANSHIP

Handles are made from top-quality, straight-grain white mountain hickory hardwood, kiln dried to 18% moisture content, then precision cut to an exact fit.

DURABLE STEEL COMPONENTS

Duckbill hooks are drop forged with the bills ground to a fine point. Clasps and extension toe rings are ductile iron castings for long-lasting service.

REPLACEMENT PARTS AVAILABLE

Replacement handles, duckbill hooks, extension toe rings and clasps are available.

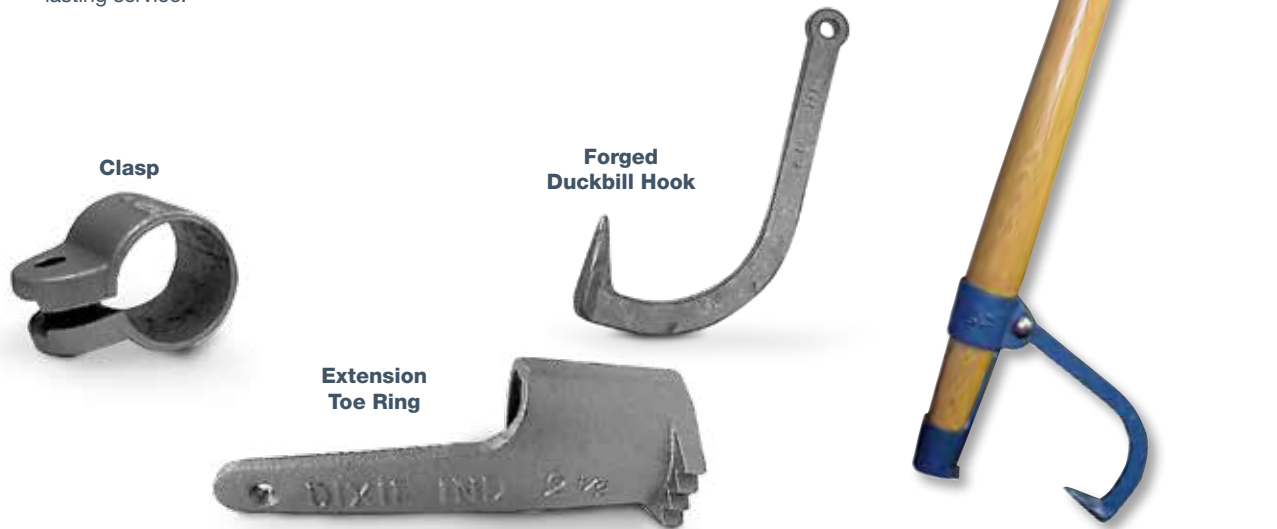

SPECIFICATIONS

Item #	For Log Sizes (in.)	Total Weight (lbs.)	Replacement Handle item #	Handle Dia. (in.)	Handle Length (ft.)	Handle Weight (lbs.)	Duckbill Hook #	Duckbill Hook Length (in.)
Hickory Handle								
06100	6 to 16	4.6	06102	2-1/4	2	2.0	24010	7/16 x 7/8 x 8
06110	6 to 16	6.0	06112	2-1/4	2-1/2	3.0	24010	7/16 x 7/8 x 8
06120	6 to 16	6.4	06122	2-1/4	3	3.5	24010	7/16 x 7/8 x 8
06130	6 to 16	7.0	06132	2-1/4	3-1/2	3.8	24010	7/16 x 7/8 x 8
06140	6 to 16	8.3	06142	2-1/4	4	4.0	24010	7/16 x 7/8 x 8
06240	6 to 16	10.1	06242	2-1/2	4	5.0	24010	7/16 x 7/8 x 8
06250	8 to 24	11.7	06252	2-1/2	4-1/2	5.5	24230	1/2 x 1 x 9
06260	8 to 24	13.5	06262	2-1/2	5	6.0	24230	1/2 x 1 x 9

Dixie Industries cant hooks can be built to customer specifications upon request.

PEAVIES

Dixie peavies, similar to cant hooks, are used to move, roll, slide or float logs or poles into position. The spike is rammed into a log or pole, then the hook grabs the log at a second location. Once engaged, the handle gives the operator leverage to reposition it. The pointed tip also makes it easier to get in between poles to separate them. Dixie Industries manufactures two styles of peavies: a tubular steel socket style and a rafting/bangor style.

FEATURES & BENEFITS

HIGH-QUALITY MATERIALS AND CRAFTSMANSHIP

Handles are made from top-quality, straight-grain White Mountain Hickory hardwood, kiln dried to 18% moisture content, then precision cut to an exact fit.

DURABLE STEEL COMPONENTS

Duckbill hooks are drop forged with the bills ground to a fine point.

EASY TO REPAIR

The Dixie bangor-style peavey, our lightest tool, features a drop-forged pick, precision welded into a drawn carbon steel socket. This one-piece unit makes field repairs easier.



SPECIFICATIONS

Item #	For Log Sizes (in.)	Total Weight (lbs.)	Replacement Handle Item #	Handle Dia. (in.)	Handle Length (ft.)	Handle Weight (lbs.)	Duckbill Hook #	Duckbill Hook Length (in.)
Solid Steel Socket Style Peavey								
00240	6 to 16	10.5	00242	2-1/2	4	5.0	24010	7/16 x 7/8 x 8
00250	8 to 24	11.3	00252	2-1/2	4-1/2	5.5	24230	1/2 x 1 x 9
00260	8 to 24	12.4	00262	2-1/2	5	6.0	24230	1/2 x 1 x 9
Rafting/Bangor Style Peavey								
03240	6 to 16	8.5	03242	2-1/2	4	4.0	24010	7/16 x 7/8 x 8
03250	8 to 24	10.3	03252	2-1/2	4-1/2	5.5	24230	1/2 x 1 x 9
03260	8 to 24	12.0	03262	2-1/2	5	6.0	24230	1/2 x 1 x 9

Dixie Industries peavies can be built to customer specifications upon request.

PIKE POLES

Originally manufactured to control floating timber in log drives, pike poles are also commonly used to move and position logs and poles in right-of-way clearing and utility maintenance and construction. Dixie manufactures these poles with two types of handles - aluminum and ash.

FEATURES & BENEFITS

STRONG AND DURABLE HOOKS

All pike hooks are manufactured from a single piece of high-carbon steel and drop forged to withstand extensive use.

ALUMINUM HANDLE

Anodized aluminum lasts considerably longer than non-anodized aluminum when used in corrosive or wet environments. Aluminum pike poles are considerably lighter than the same lengths made with ash and will not warp or break with continued use. Dixie's exclusive CORE LOK rubber seal assures a watertight barrier. Aluminum-handled pike poles come with plastic knobs (wooden knobs also available).

ASH HANDLE

All ash handles are second growth American ash with straight grain throughout the entire handle length. Ash is used in pike poles because it is lighter in weight than other woods and offers extremely long grains, increasing resiliency to tearing before breaking.

MIDGET PIKE POLES

Midget pike poles have the same features and benefits as the full-sized poles, but are shorter in length. These are ideal for use in confined areas or where a longer pole would be difficult to handle and maneuver.

SPECIFICATIONS

Handle Item #	Approx. Description	Package Dia. (in.)	Length (ft.)	Weight ea. (lbs.)	Quantity
10082	Aluminum Pike Pole	1.5	6	3.3	3
10002	Aluminum Pike Pole	1.5	8	4.0	3
10012	Aluminum Pike Pole	1.5	10	4.8	3
10022	Aluminum Pike Pole	1.5	12	5.6	3
10032	Aluminum Pike Pole	1.5	14	6.3	3
10042	Aluminum Pike Pole	1.5	16	7.0	3
10062	Aluminum Pike Pole	1.5	20	8.6	3
10072	Aluminum Pike Pole	1.5	24	9.9	3
ASH HANDLE PIKE POLES					
10080	Pike Pole	1.5	6	4.2	3
10687	Replacement Handle	1.5	6	3.1	3
10000	Pike Pole	1.5	8	5.3	3
10607	Replacement Handle	1.5	8	4.2	3
10010	Pike Pole	1.5	10	6.3	3
10617	Replacement Handle	1.5	10	5.3	3
10020	Pike Pole	1.5	12	7.3	3
10627	Replacement Handle	1.5	12	6.3	3
10030	Pike Pole	1.5	14	8.3	3
10637	Replacement Handle	1.5	14	7.3	3
10040	Pike Pole	1.5	16	9.4	3
10647	Replacement Handle	1.5	16	8.3	3
MIDGET PIKE POLES					
13920	Midget Pike Pole - Ash	-	3	2.7	3
13922	Ash Replacement Handle	-	3	1.5	3



Aluminum Handle Pike Pole

Ash Handle Pike Pole



Midget Pike Poles

CERTIFIED LIFTING TONGS

To help decrease the risk of dropped or broken poles and logs, the utility industry relies on these tongs that are certified for lifting versus standard skidding tongs. Their tong-shaped design provides a secure grip.

FEATURES & BENEFITS

HIGH STRENGTH AND DURABILITY

Tongs are made from upset-forged round micro-alloy steel for optimum tensile strength and durability.

CERTIFIED FOR LIFTING

All Dixie certified lifting tongs are proof loaded to 2 times the working load limit then affixed with a permanent metal identification tag. Written certification is also supplied at time of shipment.

CORROSION PROTECTION

Tongs are painted orange for protection against corrosion in harsh environments and for easy identification on the job site.

SECURE ATTACHMENT AND SUPPORT

Lifting tongs are supported by either a screw pin shackle or nut & bolt safety shackle with a ring.

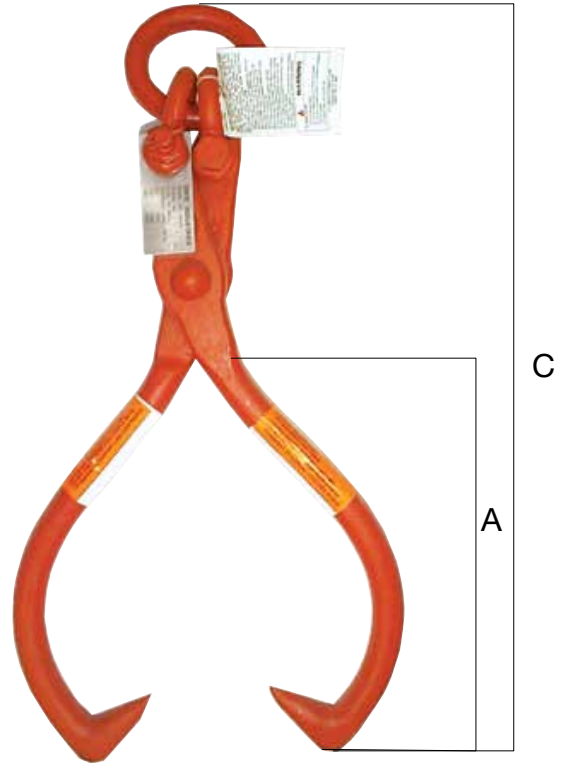

SPECIFICATIONS

Item #	Material Diameter & Maximum Opening (in.)	Close Height "A" (in.)	Overall Height "C" (in.)	Attachment/Support Type		Working Load Limit (WLL) at Degree of Opening						Approx. Weight (lbs.)
						75°		135°		180°		
				Shackle Size (in.)	Ring Size (in.)	Jaw Open (in.)	WLL (lbs.)	Jaw Open (in.)	WLL (lbs.)	Jaw Open (in.)	WLL (lbs.)	
40008	3/4 x 16	7	18-3/4	3/8 N/B*	5/8 x 2-3/4	3-3/8	1,500	12	1,000	16	750	7.0
40218	1 x 20	9	23-1/4	1/2 N/B	3/4 x 3	4	2,500	17	2,000	20	1,500	16.5
40228	1 x 25	10	25-1/4	1/2 N/B	3/4 x 3	4-1/2	2,500	20	2,000	25	1,500	17.0
40458	1-1/4 x 32	14	31	5/8 N/B	7/8 x 3-1/4	7	3,000	27	2,500	32	2,000	36.0
40558	1-1/2 x 36	16	37-3/4	3/8 N/B	1 x 4	7-1/2	5,000	32	4,000	36	3,000	50.5

Warning: Do not exceed the working load limit. The WLL decreases as you increase the size of the jaw opening. Do not heat tongs to sharpen points. Do not exceed maximum rated capacity.

*NB= nut and bolt





GENERAL RIGGING PRODUCTS

- 62 **CHAIN**
- 64 **CHAIN SLINGS**
- 66 **HOOKS**
- 68 **RINGS AND LINKS**
- 70 **SHACKLES**
- 71 **WIRE ROPE ATTACHMENTS**
- 72 **LOAD SECUREMENT**







CHAIN

Our chain manufacturing roots date back to the late 1800s and the Columbus Chain Company. We hold patents in chain and chain link design as well as patents in chain manufacturing processes, which help ensure our chain is the strongest and most reliable on the market today. We also invented the first alloy chain in 1933 – the forerunner to our industry-changing Herc-Alloy 800® and 1000 chains.

Today, Columbus McKinnon is an industry-leading chain manufacturer. Relying on more than a century of chain-making expertise and innovation, we manufacture a wide selection of welded graded chain in Tennessee, for use in a variety of industries. We have always been an innovator in chain and rigging products, and we continually work to improve our processes and materials to ensure we manufacture the best chain in the industry year after year.

GRADED WELDED CHAIN AT A GLANCE

	ASTM & NACM Grade	CM Chain Embossment	ASTM Specification	Name	Typical Uses
	GRADE 30	G30	A413	Proof Coil	General-purpose, low-carbon chain for industrial and agricultural applications including guard rails, logging and load securement. Not to be used for overhead lifting.
	GRADE 43	G43	A413	High Test	Grade 43 chain is manufactured to meet ASTM & NACM specifications. Typical uses include container securement, logging, towing and marine industry applications. Grade 43 is available in many finishes. Not to be used for overhead lifting.
	GRADE 70	G70	A413	Transport	A higher-strength, heat-treated carbon steel chain typically used by truckers, loggers and highway crews for load securement, towing, lashing and as trawler chain. Load ratings of Grade 70 chain are approximately 20% higher than Grade 43. Not to be used for overhead lifting.
	GRADE 80	HA800	A391	Alloy	A higher-strength, heat-treated alloy steel chain primarily used as a sling component for overhead lifting, but can also be used in rigging and tie-down applications where a lighter weight, higher strength chain is desirable. Recommended for overhead lifting by NACM, ASME and OSHA.
	GRADE 100	HA1000	A973	Alloy	With approximately 25% higher strength than Grade 80, Grade 100 chain is used primarily as a sling component for overhead lifting. Grade 100 chain can be used for all of the same applications as Grades 30 through 80. Recommended for overhead lifting by NACM, ASME and OSHA.

DIMENSIONS, WEIGHTS & WLL

Chain Size (in.)	Wire Diameter Nominal (in.)	Inside Length Nominal (in.)	Inside Width Nominal (in.)	Weight Per 100 ft (lbs.)	Working Load Limit (lbs.)
GRADE 30 (PROOF COIL)					
1/2	0.50	1.73	0.81	227.0	4,500
5/8	0.63	1.92	0.86	363.0	6,900
3/4	0.78	2.40	1.07	568.0	10,600
GRADE 43 (HIGH TEST)					
1/2	0.50	1.73	0.81	227.0	9,200
5/8	0.63	1.92	0.86	363.0	13,000
3/4	0.78	2.40	1.07	568.0	20,200
GRADE 70 (TRANSPORT)					
1/4	0.39	0.84	0.47	76.4	3,150
5/16	0.33	1.10	0.50	96.9	4,700
3/8*	0.39	1.25	0.57	144.0	6,600
1/2	0.53	1.56	0.73	267.0	11,300
HERC-ALLOY 800® (GRADE 80)					
7/32	0.22	0.68	0.31	44.3	2,100
9/32	0.28	0.88	0.40	72.9	3,500
5/16	0.32	1.02	0.46	90.9	4,500
3/8	0.39	1.25	0.57	144.0	7,100
1/2	0.51	1.44	0.73	255.0	12,000
5/8	0.63	1.78	0.86	382.3	18,100
3/4	0.79	2.23	1.07	595.0	28,300
7/8	0.88	2.25	1.14	776.0	34,200
1	1.00	3.07	1.49	941.0	47,700
1-1/4	1.25	3.92	1.74	1,420.0	72,300
HERC-ALLOY® 1000 (GRADE 100)					
7/32	0.22	0.68	0.31	44.3	2,700
9/32	0.28	0.88	0.40	72.9	4,300
3/8	0.39	1.25	0.57	144.0	8,800
1/2	0.51	1.56	0.73	246.0	15,000
5/8	0.63	1.92	0.86	370.0	22,600
3/4	0.79	2.40	1.07	577.0	35,300

* Standard Link Grade 70 Chain

GRADE 30



GRADE 43



GRADE 70



GRADE 80



GRADE 100





CHAIN SLINGS

Chain slings are a combination of chain, hooks, rings or other attachments used primarily for overhead lifting applications. Slings are generally used in conjunction with a crane or some type of lifting device and allow riggers to create a custom configuration to lift a load depending on the needs of the unique application.

CHAIN SLING CONFIGURATIONS

Standard sling configurations consist of chain branches that are affixed on one end to a master link or ring with some type of attachment, typically a hook, attached to the opposite end. CM manufactures a variety of standard sling configurations, including single, double, triple and quad chain slings. The following symbols are used to describe a sling.

FIRST SYMBOL (BASIC TYPE):

- S** : Single chain sling
- C** : Single choker chain sling with a standard end link on each end, no hooks.
- D** : Double branch chain sling (2 legs)
- T** : Triple branch chain sling (3 legs)
- Q** : Quadruple branch chain sling (4 legs)

SECOND SYMBOL (TYPE OF MASTER OR END LINK):

- O** : Oblong master link of standard dimensions
- P** : Pear shaped master link (available on request)
- R** : Ring

THIRD SYMBOL (TYPE OF HOOK):

- S** : Sling Hook
- G** : Grab Hook
- F** : Foundry Hook
- L** : Latchlok

A hook safety latch is not required by OSHA. However, if a latch is present it must be in working condition.

If attachments are other than standard, give detailed specifications.

Sling tags are stamped 1 to 4 to reflect number of branches. Additional coding is defined as follows:

- | | |
|-------------------------------------|-------------------------------------|
| AS : Adjustable Single | SB : Single Basket |
| ES : Endless Single | ED : Endless Double |
| SAL : Single Adjustable Loop | DAL : Double Adjustable Loop |
| AD : Adjustable Double | DB : Double Basket |

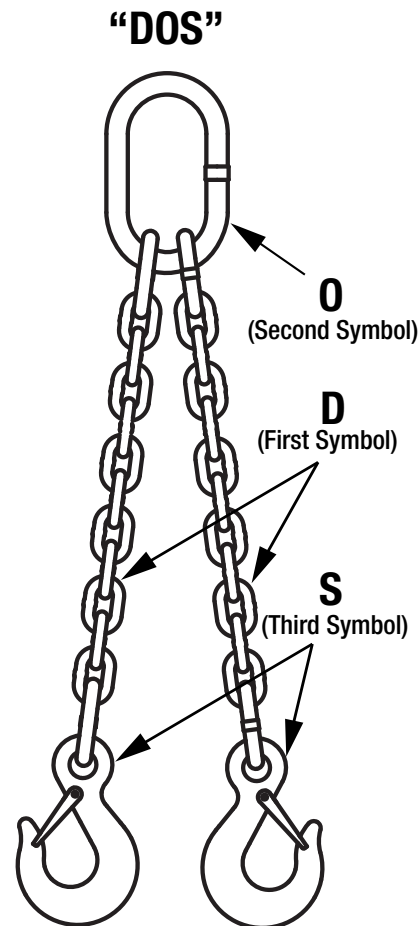

Special configurations available upon request.



STANDARD TYPES OF CM CHAIN SLINGS

SINGLE CHAIN SLINGS : TYPE S & C

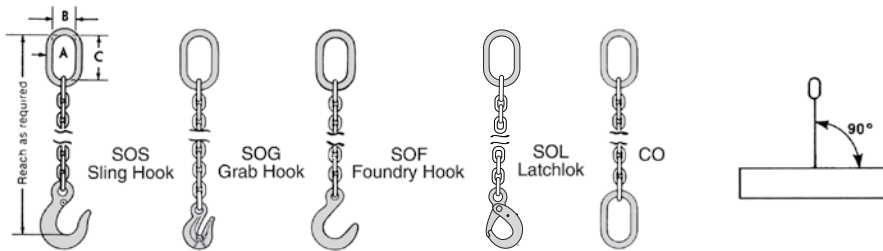

DOUBLE CHAIN SLINGS : TYPE D

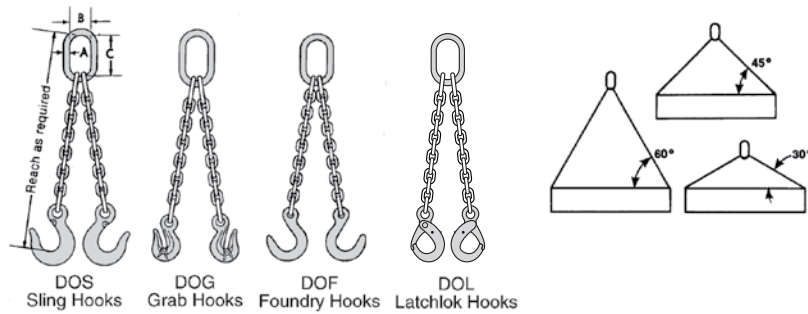

TRIPLE CHAIN SLINGS : TYPE T

QUADRUPLE CHAIN SLINGS : TYPE Q

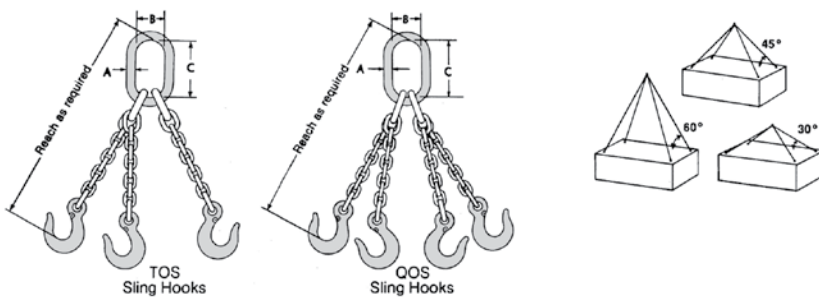

SAFETY NOTE

A quad branch chain sling, especially when used on a load of rigid structure, is usually not sustaining the load evenly on each of its four branches. The maximum working load limits are therefore set at the same values as triple branch chain slings of equal quality and size with branches used at same angle of inclination.

SLING ID TAGS

CM sling configurations come with an affixed metal identification tag that includes

- ▲ Sling size
- ▲ Sling reach
- ▲ Working load limit (all slings must be rated by their weakest component)
- ▲ Serial number
- ▲ Manufacturer name (CM) and grade of sling
- ▲ Number of branches

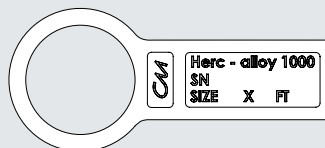

Permanently affixed sling ID tags are required per ASME B30.9 and OSHA 1910.184. To order replacement sling ID tags, contact customer service.



HOOKS

Whether you're lifting, pulling, towing or securing loads, the Columbus McKinnon line of hooks has you covered. Our history in rigging-type products dates back more than 100 years, and we rely on this long-standing knowledge and expertise to develop durable and reliable hooks that can stand up to even the toughest overhead lifting and binding applications.

Available in numerous grades and materials, we have a variety of hook styles for both overhead and non-overhead lifting applications. Learn more about all of our available hook styles below.

OVERHEAD LIFTING HOOKS

Not all hooks are appropriate for overhead lifting. When choosing an overhead lifting hook, it's important to consider the application you will be using it for. If you are lifting a plate, you may need one type of hook, while lifting a vehicle engine may require another. **Only alloy hooks should be used in overhead lifting applications.** Below are various types of hooks CM recommends for overhead lifting applications.

CLEVLOK® HOOKS

CM trademarked Clevlok® Herc-Alloy® Hooks are typically used for overhead lifting applications. This line of hooks offers easy installation in the shop or in the field. These hooks are 100% proof tested at the factory, thus requiring no additional testing once installed.



Grab Hooks Sling Hooks Foundry Hooks Latchlok® Hooks

EYE HOOKS

CM Herc-Alloy® Eye Hooks are an excellent choice for welded assemblies. For some applications, they also may be used with mechanical couplers such as the CM Hammerlok®. These hooks are designed for overhead lifting and can be used in place of Clevlok® hooks if preferred. Overhead lifting eye hooks are 100% proof tested at the factory, thus requiring no additional testing once installed using the CM Hammerlok.



Grab Hooks Sling Hooks Foundry Hooks Latchlok® Hooks Rigging Hooks

“S” HOOKS

CM Herc-Alloy® “S” Hooks are built and designed for special lifting applications. CM “S” hooks are 100% proof tested at the factory and can be used for various applications where a wide throat opening is desired.



PLATE HOOKS

CM Herc-Alloy® Plate Hooks are designed for lifting plate material, like steel, in vertical and horizontal orientations. Plate hooks should be used in pairs and careful attention should be paid to sling angles when determining the working load limit.



SORTING HOOKS

CM Sorting Hooks are designed to lift and move material with long narrow throat openings. Sorting hooks are 100% proof tested and are available with and without handles.





NON-OVERHEAD LIFTING HOOKS

Non-overhead lifting hooks are designed for pulling or load securement application. These hooks do not have the same requirements as those used for overhead lifting. Non-overhead lifting hooks are available in Grades 30, 43, and 70. Grade 80 hooks that are not suitable for overhead lifting are marked T-80 and should only be used for load securement.

CLEVIS HOOKS

Clevis Hooks are not designed for overhead lifting, but instead are most often used for load securement with tie-down chains. Clevis hooks are easy to install in the field and can be used in combination with various grades of chain including Grade 30, 43, 70 and 80. These feature a U-shaped attachment point with a pin to secure chain or other rigging attachments. Different grades of clevis hooks have different working load limits, therefore you must ensure you use the correct hook grade and size for your application.



Grab Hooks Slip Hooks

EYE HOOKS (NON-CRADLE GRAB & SLIP HOOKS)

Standard Eye Hooks are not designed for overhead lifting, but instead are most often used for load securement with tie-down chains. Eye hooks are used in combination with various grades of chain including Grade 30, 43, 70 and 80. Eye hooks feature a simple circular attachment point for rigging chain or other attachments. Different grades of eye hooks have different working load limits, therefore you must ensure you use the correct hook grade and size for your application.



Grab Hooks Slip Hooks

HOOK INSPECTION & USE

INSPECTION:

- ▲ Discard hooks that are worn more than 10% of the original dimension or are worn beyond a specific dimension or tolerance as provided in a wear allowance table, chart or diagram.
- ▲ Discard hooks that have an increase in throat or slot opening more than 5% of the original opening (not to exceed 1/4 inch).
- ▲ Discard hooks with any visibly apparent bend or twist from the plane of the unbent hook.
- ▲ Replace load pins that are permanently distorted.
- ▲ Hooks should not be subjected to bending, exposed to sharp objects or tip loaded.
- ▲ Replacement load pins shall be obtained from the manufacturer of the hook.

USE:

- ▲ Care should be exercised during use, so the hook is not abused or damaged.
- ▲ Hooks attached to chain should be selected to match the size and working load limit of the chain.
- ▲ Do not exceed the working load limit or shock load the chain or attachments. Loads applied rapidly or dropped freely can result in serious overloading of the hook.
- ▲ Use proper size chain in the throat of the grab hook.
- ▲ Hooks should not be subjected to bending, exposed to sharp objects, tip loaded (unless specified by the manufacturer) or loaded in a manner inconsistent with its design.
- ▲ Avoid exposure to corrosive mediums or high temperatures that could affect the thermal treatment and strength of the hook.
- ▲ Hooks can be used from -40 degrees F to 400 degrees F without reduction of working load limit. Call the manufacturer if you exceed these temperatures.

Refer to American Society of Mechanical Engineers ASME B30.10 for a discussion of hooks, inspection procedures and operating practices.

HOOK LATCHES



CORRECT INCORRECT
Hook latches (when required) must be in good working condition. If not, the hook should be removed from service.

NEVER TIP LOAD A HOOK!

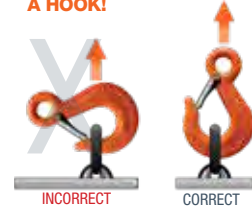

INCORRECT CORRECT

90° MAX INCLUDED ANGLE FOR HOOKS

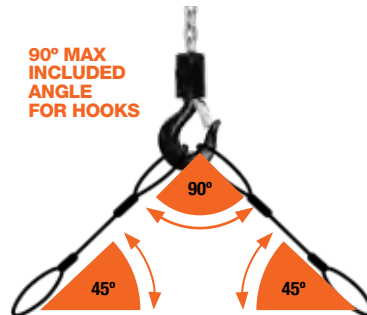

SELECTING THE RIGHT SIZE HOOK/SLING

Be sure the component is of adequate size and shape so that it can be properly seated in the saddle of hook or lifting device.



LOW HORIZONTAL ANGLES

Use a shackle or oblong master link when working with low horizontal angles. Both can be used with included angles up to 120°.

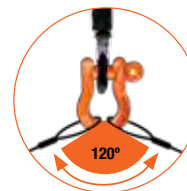

Always verify manufacturer's information prior to use.





RINGS & LINKS

While alloy steel rings and links may be used individually for lifting and rigging applications, they are used most frequently as components of a sling. Rings and links are sized for use with Grade 80 or Grade 100 chain and enable the user to construct a balanced sling system for lifting and rigging. We offer a variety of rings and links suitable for overhead and non-overhead lifting applications, explained in detail below.

OVERHEAD LIFTING RINGS & LINKS

MASTER RINGS

Master Rings are an important part of most rigging applications and can be used universally because of their round configuration.

OBLONG MASTER LINKS

Featuring an optimum design for sling construction, Oblong Master Links have a greater capacity when compared with master rings of the same size because of their smaller width. Oblong master links' oval shape is also ideal for use with crane hooks, since the depth of a crane hook is normally greater than the width.

PEAR-SHAPED MASTER LINKS

These links may be used for the same applications as oblong master links, but their design is not optimum for multiple branch slings and, in some cases, may interfere with the crane hook.



OBLONG MASTER LINK SUB-ASSEMBLIES

Designed primarily for constructing slings with multiple branches, Oblong Master Link Sub-Assemblies allow you to construct a sling using mechanical couplers between the welded master couplers and the chain branches.



HAMMERLOK® COUPLING LINKS

Constructed of drop forged alloy steel and used primarily in the construction of overhead lifting slings. Specifically used for connecting the chain branches to the master link and to the hook attachments. Dual-rated Hammerloks® meet the strength levels of Grade 80 and 100. Must be matched to the chain size. Not to be used for repair or splicing of the chain.



A Columbus McKinnon Original. ▶
First introduced by Columbus McKinnon in 1955, the CM Hammerlok® coupling link made it possible for riggers to build chain slings at the job site.

NON-OVERHEAD LIFTING RINGS & LINKS

MID-LINKS

Mid-Links are typically used for quick repair, both temporary and permanent, of chain or for attaching chain hooks, rings and swivels to chain. They should not be used for overhead lifting. Can be used for cargo securement.



▶ LINK INSPECTION & USE

INSPECTION:

Care should be exercised so that the ring and link(s) are not abused in any way during use.

- ▲ Links should not be subjected to bending or exposed to sharp corners or objects.
- ▲ Avoid exposure to corrosive mediums or high temperatures.

Visually inspect all rings and links before each use for the following conditions:

- ▲ Twists or bends
- ▲ Nicks or gouges
- ▲ Excessive wear at bearing points (innerlink area)
- ▲ Elongation (link elongation)
- ▲ Corrosion or other obvious damage

Since any of these conditions can affect the strength of the attachments shown above, a qualified person should conduct the inspection and determine whether replacement is necessary.

⚠ WARNING

Improper use or care of rings and links can result in bodily injury or property damage. To avoid injury:

- ▲ Always inspect before use for wear, damage, and elongation.
- ▲ Do not use if excessively worn or damaged.
- ▲ Never exceed the working load limit.
- ▲ Ensure the proper size link is used, and the working load limit of the ring or link is equal to or greater than the working load limit of the chain.
- ▲ Do not impact or shock load. Apply load slowly.
- ▲ Do not use on oversize crane hooks where link does not fit in saddle of the hook.
- ▲ Protect from corrosion.
- ▲ Use only alloy chain and attachments for overhead lifting.
- ▲ Do not use Hammerlok® coupling links or any of the couplers shown above to repair alloy chain for overhead lifting.



SHACKLES

Columbus McKinnon prides itself on providing the strongest and most reliable shackles on the market. We carry a full line of anchor and chain shackles manufactured in the U.S.A. through our state-of-the-art forging process.

CM shackles are available in four materials, including carbon, super strong and alloy. Our innovative Super Strong Shackles are unique in the industry, featuring strength ratings up to 50 percent stronger than comparable sized carbon shackles and a 6:1 design factor for ultimate safety.

CM shackles are available in a three styles: Screw Pin; Bolt, Nut & Cotter; and Round Pin. Learn more about the uses and benefits of each shackle style below.

BOLT, NUT & COTTER SHACKLES

Of all shackle types, Bolt, Nut and Cotter Shackles provide the most secure pin arrangement, resisting axial and torsional loading. This type of shackle should be used in semi-permanent applications where the pin is removed infrequently or where cyclical loading occurs. This is the preferred type of shackle in areas that are difficult to reach or inspect. Recommended for overhead lifting, bolt, nut and cotter shackles are available in capacities up to 150 tons.



SCREW PIN SHACKLES

Screw Pin Shackles allow for quick and easy removal of the screw pin, which makes this style ideal for applications where the shackle is removed frequently. While the threaded pin can resist axial forces, it should not be cyclically loaded and is unreliable and vulnerable to backing out in applications where the pin is subjected to a torque or twisting action. Recommended for overhead lifting, screw pin shackles are available in capacities up to 43 tons. Screw pins should be moused in some applications.



ROUND PIN SHACKLES

Round Pin Shackles allow for easy removal by simply removing the cotter that holds the pin in place. These shackles perform well where the pin is subjected to a torque or twisting action, but they should not be subjected to an axial load. Round pin shackles are available in capacities up to 43 tons and are not recommended for overhead lifting.



3 TYPES OF SHACKLE MATERIAL

MATERIAL	STYLE	WLL (TONS)	SIZES (IN.)	STYLES	DESIGN FACTOR	FINISHES
CARBON	Anchor	1/3 to 85 ton	3/16" to 3"	Bolt, Nut & Cotter; Screw Pin; Round Pin	6:1*	Orange Powder Coated, Galvanized
	Chain	1/2 to 35 ton	1/4" to 2"			
SUPER STRONG 17 to 50% stronger than comparable-sized Carbon	Anchor	1/2 to 55 ton	3/16" to 2-1/2"	Bolt, Nut & Cotter; Screw Pin; Round Pin	6:1**	Orange Powder Coated, Self Colored, Galvanized
	Chain	3/4 to 35 ton	1/4" to 2"			
ALLOY (U.S.) ~50% stronger than comparable-sized Carbon and ~25% stronger than Super Strong	Anchor	2 to 120 ton	3/8" to 3"	Bolt, Nut & Cotter; Screw Pin; Round Pin	5:1	Orange Powder Coated, Self Colored, Galvanized

** Round pin and all 2-1/2" super strong shackles have a 5:1 design factor

WIRE ROPE ATTACHMENTS

Wire rope is frequently used to make slings for rigging applications. The CM portfolio of wire rope attachments, including wire rope clips and turnbuckles, are used to secure loops or turn back wire rope when used as part of a sling. Learn more about our specific wire rope attachment products and their uses below.

WIRE ROPE CLIPS

Wire Rope Clips are used to secure the end of wire rope when forming a loop; i.e., for wire rope turn-back. Clips are available in two configurations: mid-grip (double saddle) and single saddle. Each configuration is equally strong and effective, but care must be exercised for proper installation of single saddle clips; i.e., saddle must rest against live end of wire rope. All clips should be used in conjunction with a wire rope thimble and may require torquing.

NOTE: Wire rope clips are not recommended for fabricating slings for overhead lifting. Reference ASME B30.9 for special applications.

MID-GRIP WIRE ROPE CLIPS

The CM Mid-Grip is designed for applications in the scaffolding industry. The redesigned mid-grip features a hexagon bolt head that fits securely into a forged, hex-shaped socket that prevents spinning even after repeated use and re-torquing. It has precise threading on the nut and bolt to ensure tight alignment. This design also allows for full arc wrench swing, making installation and retightening quick and easy. The mid-grip meets FF-C-450 performance requirements and comes with a smooth, mechanical galvanized finish for protection in harsh environments.

BUNDLING CLIPS

The CM Bundling Clip is built for harsh environments and demanding applications of the oil and gas industry. They are user-friendly with an easy-to-assemble, U-shaped design, allowing for fewer dropped or lost parts. The CM bundling clip design eliminates shear points and damage to wire rope, and prevents the choker from going slack and the load spreading after tension is released from the sling.



PIGGYBACK® WEDGE SOCKET CLIPS

The CM PiggyBack® Wedge Socket Clip is the only clip on the market specifically designed for securing the dead end of a wire rope on a wedge socket. Its revolutionary dual saddle design attaches quickly and easily to prevent crimping and damage to the live end of wire rope and eliminates the need for a short rope piece or loop on dead end. Properly secured dead end will not snag/foul and shear off at wedge socket. Available in 3/8 inch to 1-1/2 inch sizes. Hot dip galvanized with orange painted U-bolts and drop forged saddles.



TURNBUCKLES

Turnbuckles provide easy means for tensioning, loosening and removing chain and rope load lines. CM Turnbuckles are forged then hot dip galvanized. All meet Federal Specification FF-T-791b Type 1, Form 1. Turnbuckles are available in eye and eye, hook and hook, hook and eye, eye and jaw, and jaw and jaw styles in sizes from 1/4 to 1-1/2 inch thread diameter.

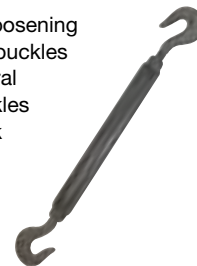



LOAD SECUREMENT

Load securement, also known as tie-down or load binding, can be a complex rigging application that often has strict specifications and regulations. CM offers a number of load securement products, including load binders, binder chain assemblies and tie-down hooks, that help you safely secure loads for transport as well as meet federal, state and Commercial Vehicle Safety Alliance (CVSA) regulations. Our load securement products comply with the National Association of Chain Manufacturers (NACM) Welded Steel Chain specifications and the American Society of Testing and Materials (ASTM) specifications. They are also designed to meet applicable Federal Motor Carrier Safety Administration (FMCSA) rules for cargo securement.

LOAD BINDERS

Load Binders are typically used to take up slack and apply tension to a tie-down system. Designed primarily for use with graded chains, they can also be used with cable, steel strap or fiber webbing to secure loads in a variety of applications. Load binders are available in two general configurations: Lever-type (over the center) and Ratchet-type. CM load binders are rated by working load limit and are provided with the appropriate hooks to accept the chain size and grade consistent with the binder's load rating.

LEVER-TYPE LOAD BINDERS

Lever-type, or over-the-center, Binders utilize mechanical advantage to reduce the manpower required to secure a load. When using a lever-type load binder, tension can be applied and released quickly. Operators should use caution, as the handle may whip suddenly. When securement is complete, the lever stores in line with load.



• Lever-Type Load Binder

RATCHET-TYPE LOAD BINDERS

Ratchet Binders utilize a screw or rotating motion to tighten and secure loads. Ratchet binders tighten slower but are easier to operate than lever-type load binders. They also do not require a handle to lock in place to ensure the binder stays tightened. Available with a variety of end fittings.



• Ratchet-Type Load Binder

RIVER RATCHETS

River Ratchets operate similar to ratchet-type load binders, but have a substantially larger capacity. Typically, these ratchets are used to gang barges utilizing a gravity-operated, double-pawl design. River ratchets are available with a variety of attachments.

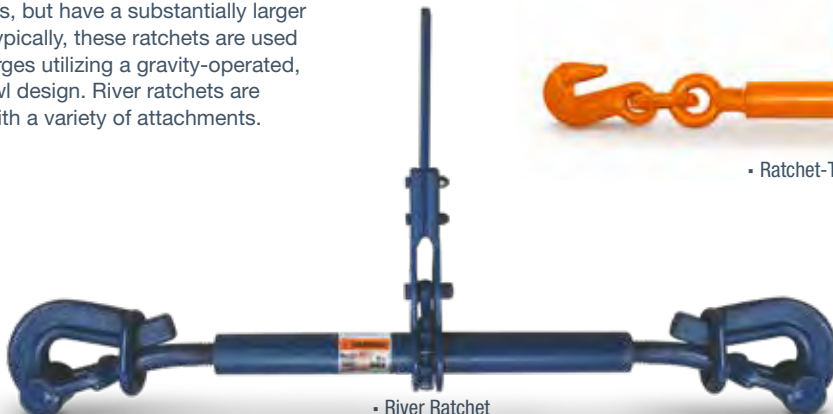

• River Ratchet

BINDER CHAIN ASSEMBLIES

Binder Chain Assemblies are most often used to secure loads to trucks, rail cars or truck trailers. They typically consist of a length of chain ranging from 6 to 26 feet in length with a grab hook at each end. The grab hook can be clevis style or eye style depending on your application. Standard binder chain assemblies are available in Grades 30, 43, 70, 80 and 100.

CLEVIS HOOK ASSEMBLIES

Clevis Hook Assemblies are available in various lengths and grades, depending on your application. CM offers different dimensional binder chains as part of these assemblies, including short link chain, which provides you with easier take up and better cornering, or traditional pitch chain that gives you less pounds per foot in weight.

EYE HOOK ASSEMBLIES

Similar to CM clevis hook assemblies, Eye Hook Assemblies prevent the loss or theft of hooks from the binder chain. Eye hook assemblies are offered with short or traditional pitch chain.



TIE-DOWN HOOKS

Tie-down Hooks come in various grades, designs and installation types. Both clevis and eye style tie-down hooks are high-quality forgings made here in the U.S. The clevis style hook is most popular because of the ability to self-install with limited need for tools. The eye style hook is typically factory installed during a welding process, but is beneficial in that it protects against loss or theft of the hook.

GRADE 70 TRANSPORT HOOKS

Transport Hooks are available in both clevis and eye types in either slip or grab styles. These hooks are rated for use with Grade 70 chain and are available in self-colored or yellow chromate finishes.



GRADE 80 HEAVY-DUTY HOOKS

Grade 80 Hooks available in both clevis and eye types in either slip or grab styles and are rated for use with Grade 80 chain. Grade 80 clevis-style hooks are marked "T80" and should not be used for overhead lifting because of their pin and cotter design. These hooks are available in self-colored or orange powder-coated finishes.



⚠ WARNING

Improper use or care of load binders can result in bodily injury or property damage.
To avoid injury:

- ▲ Never exceed working load limit.
- ▲ Always inspect binder before use for wear, damage, and elongation.
- ▲ Do not use cheater bar or handle extension.
- ▲ Do not operate load binder while anyone is on the load.
- ▲ Release load on lever type binders with extreme care. Make sure everyone is clear of the load. Handle may whip suddenly.

TRAINING OVERVIEW

Columbus McKinnon is not only a leading manufacturer of hoist and rigging products for the utility industry, it is also a global leader in providing expertise and training on the proper use, care and inspection of these products. Our professional training courses held at our state-of-the-art training centers across North America, along with our extensive offering of online training courses, provide you with everything you need to work safely and efficiently.

UTILITY HOIST MAINTENANCE CERTIFICATION

1-DAY COURSE COURSE CODE: UTL-CRT

This hands-on class is designed for those responsible for maintenance, inspection and testing of Little Mule® utility products. Instruction includes disassembly, inspection, adjustment and reassembly of the G-Series roller chain hoist, RA Series welded link chain hoist, and Lineman's strap hoists. Class size is limited to 10 students to assure maximum hands-on experience.

COURSE TOPICS:

- OSHA 1910.269 & ASME B30.21 regulations
- Hoist inspection and testing
- Hoist warning labels and markings
- Hook inspection criteria
- Load chain and web strap inspection
- Wire grip applications and configurations
- Comparison of lever hoists
- Ratchet & pawl design
- Weston brake design

HANDS-ON TRAINING:

- Disassembly
- Inspection
- Adjustments
- Re-Assembly

STUDENT WILL RECEIVE:

- Student workbook
- Certificate of course completion

CMCO Little Mule Utility Hoist Certification is optional and requires passing a multiple choice examination. Those successfully completing the exam will receive certification that is valid for 5 years. There is no additional charge for certification.

**TRAINING REGISTRATION:
CALL 877.298.6511
TRAINING.CMWORKS.COM**



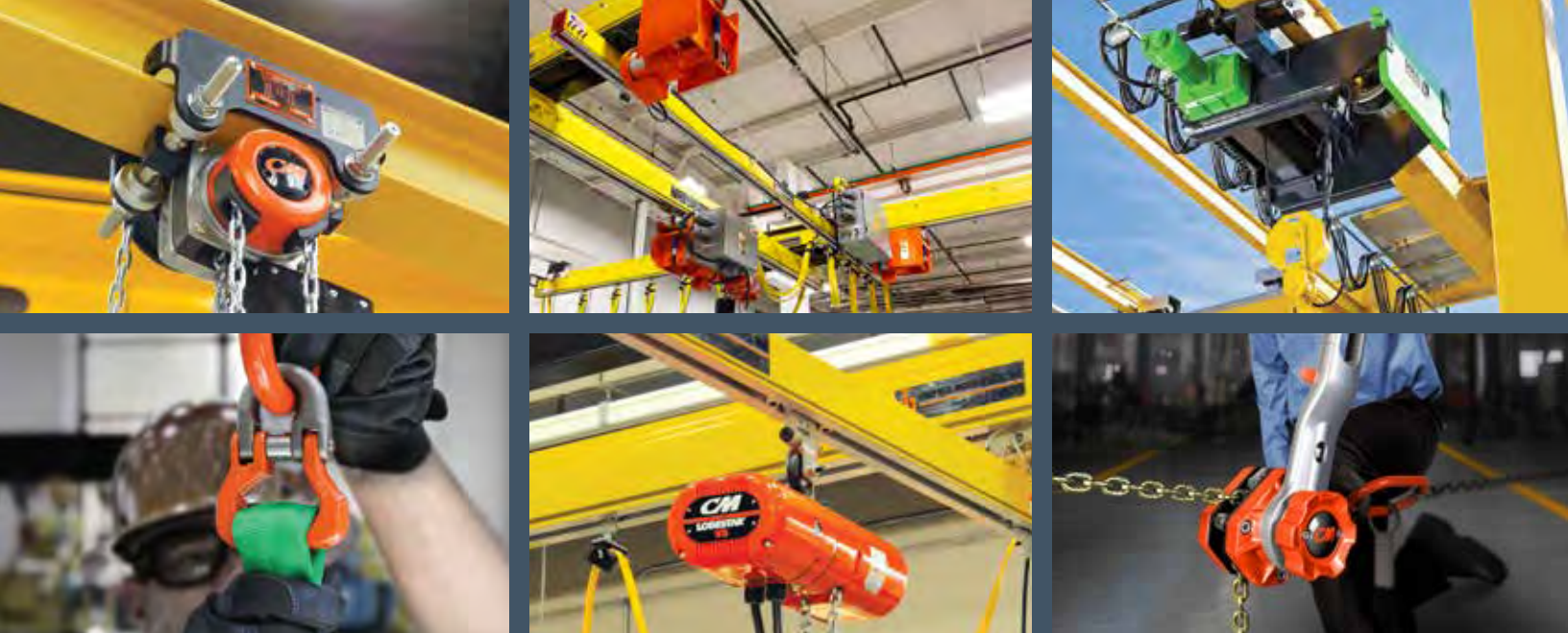

MOVING THE WORLD FORWARD

When you have a lifting, conveying or motion control challenge, we have the solution. Columbus McKinnon's intelligent motion solutions are used day in and day out in critical applications that move the world forward and improve lives. From variable speed electric chain hoists featuring Intelli-Connect™ Mobile: Drive Monitoring, Analytics, and Configuration to the CM Tornado 360™ and its revolutionary Sidewinder™ lever handle, Columbus McKinnon is engineering intelligent motion solutions for tomorrow's workforce.

BE SAFE. GET TRAINED.

Columbus McKinnon is committed to providing expert safety training on the proper use and inspection of rigging and overhead lifting equipment. Our company offers comprehensive programs at our national training centers as well as on-site at your facility. We also have an extensive offering of online courses available on our training website. Courses include hoist and rigging safety and inspection; crane operation and safety; and load securement.

Columbus McKinnon's facility in Buffalo, New York, is home to our state-of-the-art **Niagara Training Center**. The 3,000-square-foot facility is dedicated to training Channel Partners and end users on the safe and proper use of hoist and rigging products. The Center offers a one-of-a-kind training experience on chain and rigging equipment with more than 75 manual and powered hoists, enclosed track systems and our 50-foot-wide crane system with 3 ton Yale® YK™ wire rope hoist.

CMCO UNIVERSITY™

Win in the marketplace with CMCO University. This intense program is designed to give Channel Partners intimate product and application knowledge that they can use to advise their end-user customers during the product selection and sales processes.



LIFTING SOLUTIONS



USA

p: 800.888.0985

p: 716.689.5400

f: 716.689.5644

CAN

p: 877.264.6478

f: 877.264.6477

www.cmco.com | CMCOPartners@cmworks.com