

KAL SERIES
Air Powered Chain Hoist

Parts and Instruction Manual

Fill in the information below before installing the hoist.

316A

Hoist S/N _____

Trolley S/N _____

Capacity _____

Model No. _____

Date of Purchase _____

Yale

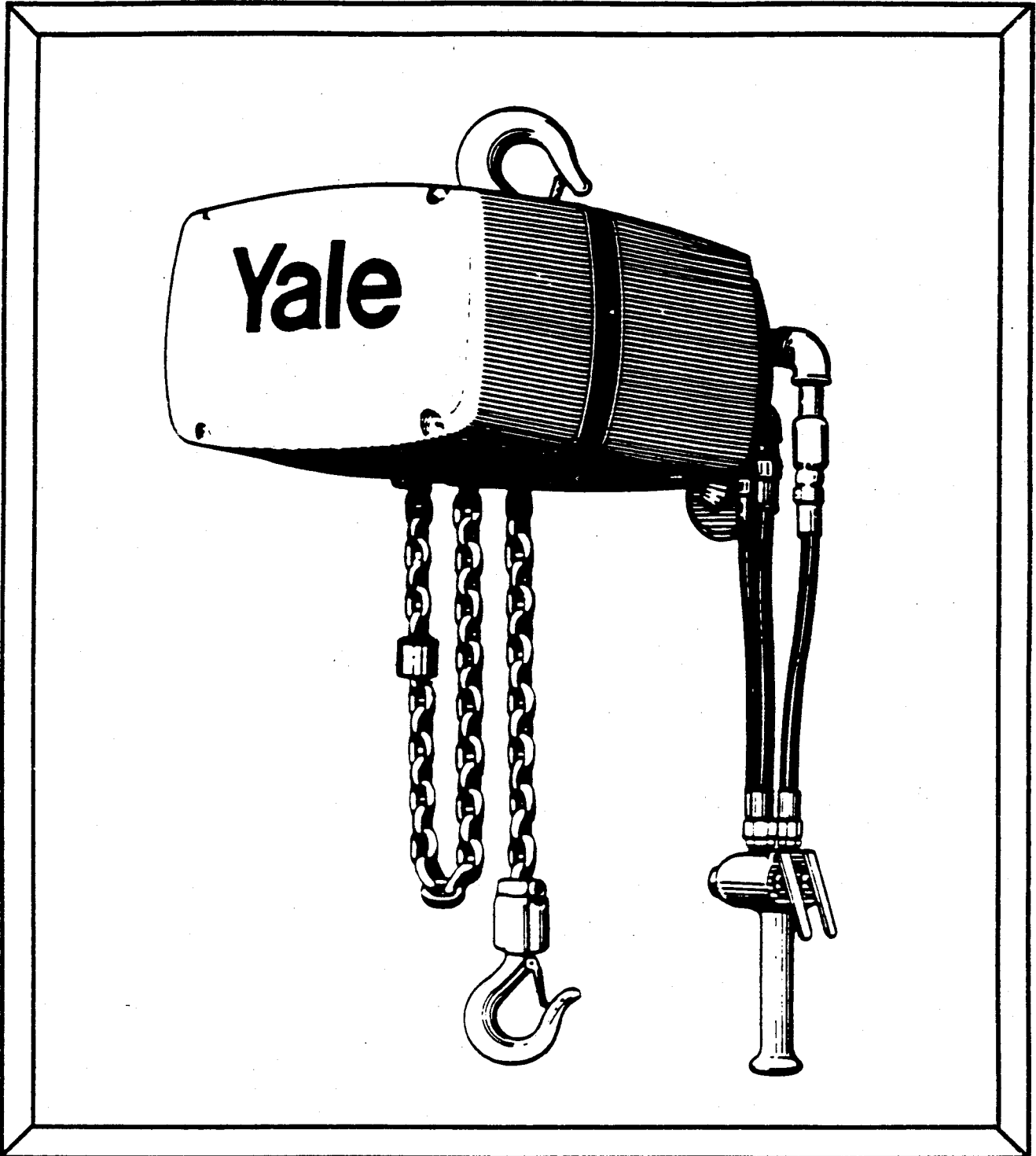

MFG. SERIES D

Yale®

- TABLE OF CONTENTS-

	<u>Page</u>
SAFE HOISTING PRACTICE.....	2
GENERAL INFORMATION.....	5
Warranty Policy.....	Inside Back Cover
Repair Parts Ordering Information.....	5
Model Number Explanation.....	5
INSTALLATION INSTRUCTIONS.....	6
Basic Suspension.....	6
Pendant Air Line Connections.....	7
Trolley Suspension.....	7
Trolley Adjustment.....	8
Function Testing.....	8
Travel Limits.....	9
Operating Instructions.....	9
PREVENTIVE MAINTENANCE.....	10
Lubrication Charts.....	10
Preventive Maintenance Schedule.....	10
Daily Inspection.....	11
Monthly Inspection.....	11
Annual Inspection.....	13
Allowable Chain Wear Chart.....	13
Function Testing.....	13
Normal and Maximum Hook Openings.....	13
TROUBLE SHOOTING GUIDE.....	14
DISASSEMBLY.....	17
Installing New Load Chain.....	17
Guide Sheet For Installing Chain.....	18
1. Recommended Sequence Of Disassembly.....	20
2. To Remove The Motor And Manifold.....	22
3. To Remove The Motor Brake.....	22
4. To Remove The Gearing Or Load Limiting Clutch.....	23
5. To Remove The Load Brake.....	23
6. To Remove The Driven Pocket Wheel And Chain Guide.....	23
7. To Remove The Top Hook Or Lug.....	23
8. To Remove The Bottom Hook.....	23
9. To Remove The Gear Case Cover.....	24
REASSEMBLY.....	24
Top And Bottom Crosshead Assembly.....	25
REPAIR PARTS.....	32
Recommended Spare Parts For One Year.....	32
Bottom Block Assemblies.....	33
Housing And Frame Parts.....	36
Gear Train And Motor Brake.....	38
Air Motor, Connections And Pendant.....	40
Suspension Parts.....	42
Trolleys.....	44
Chain Containers.....	54
AIR FLOW DIAGRAMS.....	57
AIR MOTOR TROUBLE SHOOTING, DISASSEMBLY AND REPAIR.....	59
INSPECTION RECORD SECTION.....	In Back

When Replacement Parts Are Needed, Order Only YALE® Factory Engineered Parts

Yale®

Safe Hoisting Practices

Yale AIR HOIST

For your own safety and that of your fellow workers, Material Handling Equipment must be used as recommended by the Manufacturer. Failure to heed the following recommendations could endanger your life. Use good common sense and judgment at all times. Safety is the responsibility of the operator of the equipment. You must be competent and attempt to foresee and avoid all hazardous conditions. To be safe as possible, the hoist must be given proper preventative maintenance and testing as described in the ANSI B30-16 Safety Code for Overhead Hoists and this manual.

BEFORE OPERATING HOIST:

1. Do not operate hoist unless you are properly trained, physically fit, and authorized to do so. You must be familiar with all operating controls of the hoist, warnings and instructions on the hoist, the safe hoisting practices listed in this bulletin, ANSI B30-16 Safety Code for Overhead Hoists, and all pertinent Federal, State, and local regulations before beginning operation.
2. Do not allow unqualified personnel to operate the hoist.
3. On powered hoists, test all controls and limit switches and make sure hoist is well lubricated at beginning of each shift. Make sure needed lubrication, adjustments or repairs are made by appointed personnel before operations are begun.
4. Be familiar with the equipment and its proper care. Do not operate hoist if adjustment or repairs are necessary, if any damage or undue wear is known or suspected, or if any warning, operating, or capacity instructions normally attached to hoist are damaged or missing, report same promptly to the proper person and also notify next operator when changing shifts.
5. Do not operate hoist if it is functioning improperly.
6. Do not operate hoist with an out-of-order sign attached until sign has been removed by a properly authorized person.
7. Do not adjust or repair hoist unless qualified for maintenance of hoist.
8. On powered hoists, be sure the power supply is disconnected before maintenance and repair procedure is performed.
9. Do not use the chain or rope as a ground for welding.
10. Do not touch a welding electrode to the chain or rope.

When Replacement Parts Are Needed, Order Only YALE® Factory Engineered Parts

Yale®

Safe Hoisting Practices

Yale AIR HOIST

APPLYING THE LOAD:

11. Never wrap the hoist rope or chain around the load.
12. Always use slings or other approved devices to attach load.
13. Be sure the sling is properly seated in the saddle of the hook.
14. Do not apply a load to tip of hook, or in such a way as to cause bending or prying forces on the hook or hook support block.
15. When hoisting, be sure chains or wire ropes are not kinked or twisted or that multiple part chains or ropes are not twisted about each other.
16. Do not operate hoist if wire rope or chain is not seated properly in the grooves of the drum, sheaves or sprockets.
17. On wire rope hoists, do not load hoist with less than two wraps of rope on the drum, unless a lower limit device is provided, in which case, no less than one wrap shall remain on drum.
18. Center hoist unit over the load before lifting. Avoid side pull.
19. Never pick up a load beyond the rated capacity appearing on the hoist, except for properly authorized tests.

MOVING THE LOAD:

20. Do not engage in any activity which will divert your attention while operating hoist.
21. Respond to signals from designated personnel only, except for stop signals.
22. Never lift a load with the hoist until you and all other personnel are clear of load.
23. Make sure a load clears neighboring stock piles or machinery before moving.
24. On powered hoists, inch the hoist slowly into engagement with a load, but avoid excessive plugging, inching, and quick reversals of load.
25. Do not lift load more than a few inches until it is well balanced in the sling or lifting device.

When Replacement Parts Are Needed, Order Only YALE® Factory Engineered Parts

Yale®

Safe Hoisting Practices

Yale AIR HOIST

26. Each time a load approaching rated capacity is handled, check load brake action by raising load just clear of supports and continuing only after you are sure brake is operating properly.
27. Do not transport load over personnel.
28. Never carry personnel on the hook or the load.
29. Avoid swinging of load or load hook when traveling the hoist.
30. On trolley mounted hoists, avoid sharp contact between trolleys, or between trolleys and rail stops.
31. On powered hoists, do not use limit devices as a normal means of stopping the hoist. These are emergency devices only.
32. On powered hoists, do not exceed the maximum duty cycle specified by the manufacturer.

PARKING:

33. Do not leave a load suspended in the air for extended or unattended periods.
34. On powered hoists, keep load block above head level when not in use.



CAUTION

DO NOT USE YALE HOISTS OR TROLLEYS FOR
PASSENGER ELEVATOR APPLICATIONS.

The safety laws for passenger elevators specify construction details that are not incorporated in Yale Hoists. We recommend that passenger elevator operation equipment be used that meets all state and national safety codes. Yale Hoists will not accept responsibility for applications of Yale Hoists on passenger elevators.

INSPECTION, PREVENTIVE MAINTENANCE AND TESTING

A preventive maintenance program should be initiated for this hoist immediately after it is entered into service. The preventive maintenance program should comply with recommendations in the applicable Yale Parts and Instruction Manual, and all pertinent Federal, State, and local regulations. Regular inspections, maintenance, and testing required should be followed for the life of the hoist and written inspection records kept as specified. Sample inspection check lists are included at back of this manual. Extra inspection check lists can be obtained from your nearest authorized Yale Distributor.

When Replacement Parts Are Needed, Order Only YALE® Factory Engineered Parts

Yale®

Repair Parts Ordering Information

This Parts and Instruction manual is provided as a convenience to assist you in ordering repair parts for your YALE® KAL SERIES AIR HOIST. To insure prompt service, place all parts orders with your local distributor.

Give all information listed below in items (a), (b), (c) and (d). This will enable your distributor to fill your order promptly.

- (a) Give complete data from hoist nameplate.
- (b) Give part number, description and quantity required.
- (c) Give the correct shipping destination.
- (d) For ordering motor repair parts, give all data on the hoist and motor nameplates.

If it becomes necessary to return the complete hoist or certain parts to the factory, a letter requesting such a return is necessary. This letter should contain an explanation for requesting the return. A return authorization will be issued giving you clearance for returning the hoist or parts to the factory. Should you need additional help in ordering, contact your local YALE® distributor.

Model Number Explanation

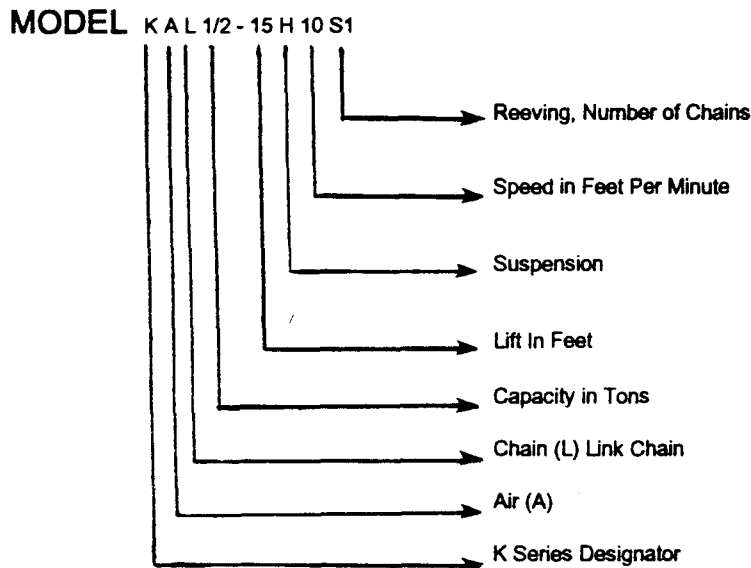

SUSPENSION

- L - LUG
- H - ROTATING TOP HOOK
- NH - NON-ROTATING TOP HOOK
- C - CLEVIS
- NC - NON ROTATING CLEVIS
- P - PLAIN TROLLEY
- G - HAND CHAIN OPERATED TROLLEY
- S - ST MOTOR OPERATED TROLLEY
- T - TT MOTOR OPERATED TROLLEY
- R - RT MOTOR OPERATED TROLLEY

FIGURE I.

When Replacement Parts Are Needed, Order Only YALE® Factory Engineered Parts

INSTALLATION

Yale®

Gear Case Vent

Before hanging the hoist, remove the vinyl plug at the top of the unit with the tag attached. The plug was to prevent oil leakage during shipment and must be removed to prevent oil leaks due to pressure buildup. Check the oil level at the level plug on the side of the unit. See lubrication chart on page 10.

Chain Lubrication

The load chain is the only component requiring lubrication prior to putting the hoist in operation. See lubrication chart on page 10.

Basic Suspension

The basic hoist suspensions are hook, and lug as shown in Figure 2 below. Unless otherwise specified, the hook suspension will be Rigid (non-rotating), Swivel Types are available. The lug suspension is rigid (non-rotating), and adjustable in 90° increments. If it is necessary to reposition the lug, refer to Pages 31, 32 and 33, Assembly Procedure.



CAUTION

FOR MAXIMUM SAFETY, ALL FASTENERS HAVE A DOUBLE LOCKING FEATURE. BE CERTAIN ALL LOCKING DEVICES ARE REPLACED WHEN REASSEMBLING.

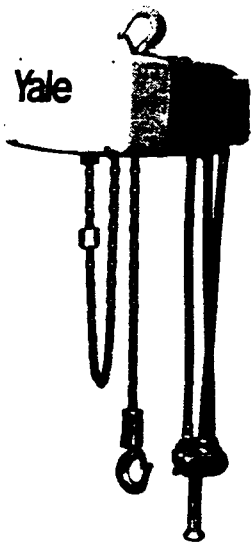

HOOK TYPE

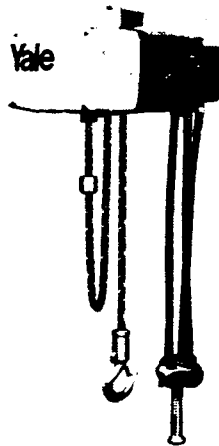

LUG TYPE

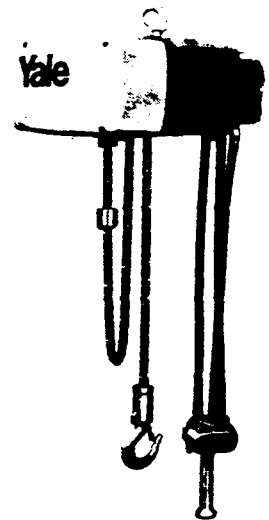

CLEVIS TYPE

FIGURE 2.

YAP-0296

When Replacement Parts Are Needed, Order Only YALE® Factory Engineered Parts

Air Supply



CAUTION:

Before connecting air to hoist make sure the pressure of the air supply corresponds with the rating listed on the hoist nameplate. Automatic air line oiler set to feed at approximately one drop per minute, a moisture trap, and a filter should be installed in the air line not more than 15 feet from the hoist inlet connection.

For efficiency of output and control of speed, use air lines the same size as, or the next pipe size larger, than the intake port of the motor.

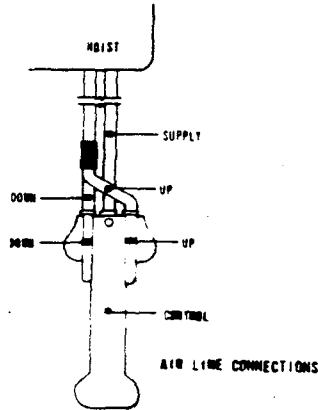

ATTACH PENDANT ASSEMBLY TO HOIST AS SHOWN ABOVE.



FIGURE 3.

Trolley Suspension

Standard Trolley Suspensions is the hand pushed type and hand chain operated. "RT" and "TT" (Not shown) air powered trolleys are also available. If the hoist is equipped with a powered trolley, it will be necessary to refer to the manual furnished with the trolley for installation and service information.

To hang hoist furnished with plain or hand geared trolley, first determine the beam size on which the trolley is to be used, then refer to page 8 for proper spacer arrangement.

Normal and Maximum Hook Openings For KAL Series Hoists



Caution: If "E" Exceeds Maximum shown in table, replace hook & check all other load bearing parts



"NORMAL OPENING E WITH SAFETY LATCH"

Dimensions In Inches		
Capacity In Tons	E Normal	E Maximum
1/2 - Bottom	1 1/32 IN.	1 7/32 IN.
1/2 - Top	1 5/32 IN.	1 27/64 IN.
1 - Bottom	1 5/32 IN.	1 27/64 IN.
1 - Top	1 5/32 IN.	1 27/64 IN.
2 - Bottom	1 17/32 IN.	1 51/64 IN.
2 - Top	1 17/32 IN.	1 51/64 IN.
3 - Bottom	2 1/8 IN.	2 15/32 IN.
3 - Top	2 1/8 IN.	2 15/32 IN..

When Replacement Parts Are Needed, Order Only YALE® Factory Engineered Parts

INSTALLATION

Yale®

Trolley Adjustment

All Yale Trolleys are normally adjusted at the factory to fit the I-Beam size stated on the order.

Note: When disassembling the trolley for installation on the I-Beam, take note of the arrangement of the spacers and washers for correct reassembly.

For installation on I-Beam other than the size preset at the factory, or if final adjustment to the beam is required, follow the instructions listed below.

Measure the I-Beam flange width and temporarily install the trolley sideplates on the hoist before installation to determine the exact distribution of washers.

The distance between track wheel flanges should be 3/16 inch greater than the beam flange width for straight runway beams, and 3/16 to 1/4 inch in runway systems that includes sharp curves. The number of washers between the sideplates and the hoist lug should be the same, or differ only by one (1) washer, in order to keep the hoist centered under the I-Beam. The distribution of washers outside the trolley sideplates is unimportant except that the total number used be sufficient to keep the nuts engaged.

Note: When installing hoist and trolley on beam, tighten nuts snugly so that the trolley sideplates are parallel and vertical.

Center the trolley on the beam and check the clearance between the wheel flange and beam flange. If the trolley is adjusted properly the clearance will be approximately 1/8".



CAUTION BE SURE THERE IS A LOCKWASHER UNDER EACH NUT.

Function Testing

After the hoist and trolley are installed on the I-Beam, operate the trolley over the entire length of the beam with a capacity load to be sure that adjustment and operation is satisfactory.

When Replacement Parts Are Needed, Order Only YALE® Factory Engineered Parts

Yale®

Travel Limits

The KAL chain hoist is equipped with a load limiting clutch to help prevent damage to the hoist which could be caused by loading the hook above 175% of rated load or overrunning the extremities of the chain. The stops attached to the chain provide a positive stop against the bottom steel crosshead in the event the usable length of the chain is overrun. The chain stop at the housing end of the chain may be repositioned further away from the chain end to further limit hook drop.

 **CAUTION**

NEVER REMOVE THE STOP AT HOUSING END OF CHAIN OR POSITION IT CLOSER THAN EIGHT LINKS FROM THE END OF THE CHAIN.

The optional chain stop near the load hook (single line models only) may be repositioned as desired to limit lift, or may be removed. A clutching noise may be heard when operating the hoist against the stops. This indicates the unit is in a dangerously overloaded or stalled condition.

 **CAUTION**

DO NOT USE THE LIMIT CLUTCH AS A REGULAR MEANS OF STOPPING THE HOOK AT EXTREMITIES OF TRAVEL OR AS A REGULAR MEANS OF MEASURING THE MAXIMUM LOAD TO BE LIFTED. THIS IS A SAFETY BACKUP DEVICE ONLY.

The load limiting clutch is a friction device, and therefore susceptible to overheating and wear. For optimum performance and long life, RELEASE THE PENDANT LEVER IMMEDIATELY WHEN THE CLUTCH SLIPS.

Operating Instructions

For your own safety and that of your fellow workers, Material Handling Equipment must be used as recommended by the manufacturer. Failure to heed the safe hoisting practices spelled out on page 2, 3 & 4 could endanger your life. Read them carefully before operating hoist.

When Replacement Parts Are Needed, Order Only YALE® Factory Engineered Parts

**PREVENTIVE
MAINTENANCE**

Hoist Lubrication - KAL Series

Yale®

PART	LUBRICANT	LUBRICATION POINT	LUBRICATION INSTRUCTIONS	DRAIN POINT
Oiler - Filter	Low Motor Oil With MS Rating	Oiler - Filter **	Check Oil Level And Refill When Necessary.	Drain From Bottom Of Filter - Oiler
Gear Case	Part No. 6496850-00* 3/4 Pt. Can of Yale Lube. Gear Case Cap. 2 1/4 Pts.	Fill Plug In Top Of Housing.	Oil Should Be Level with Side Plug In Housing.	Located In Bottom Of Unit.
Chain	Yale Part No. 51562618-01 Type SS2. (In Spray Cans) Or Keystone Graphite No. 2 Penetrating Oil For Chain. Yale Bulk #6466678-00 Or Equal.	Chain	Spray or brush oil onto chain making sure areas between links are completely covered over entire length of chain. Wipe any excess oil off outside surface of chain, leaving oil between links where lubrication is necessary. WARNING: If hoist is operated during chain lubrication, make sure hands and clothing are kept well clear of chain.	
Bottom Block and Idler Wheel Bearings	Shell Alvania No. 2 (or equal)	Bearing Surfaces And Reservoirs At The End Of The Axle.	Apply Grease To Rollers Of Bearing And Fill The Grease Reservoirs.	

* Substitutions Are Not Recommended As They Might Cause Load Brake Chatter.
** Should Be Located No More Than 15 Feet From The Hoist Inlet Connection.

RT, ST And TT Series Trolleys

PART	LUBRICANT	LUBRICATION POINT	LUBRICATION INSTRUCTIONS	DRAIN POINT
Gear Case	Gulf XXX No. 1 Grease RT- Shell Velvata Oil J82 or Equal	Socket Head Plug In Side Of Gear Case.	Fill Until Grease Is Level With Hole.	Socket Head Plug In Bottom Of Gear Case.
Track Wheel	Moly Cote	Pinion And Gear Teeth	Depending On Application, Light Coating Of Grease.	

Hand Chain Operated Trolley

PART	LUBRICANT	LUBRICATION POINT	LUBRICATION INSTRUCTIONS
Hand Chain Guide	Gulf Crown No. 2	Alemite Fitting	Lubricate Until Grease Can Be Seen
Support Bracket	Gulf Crown No. 2	Alemite Fitting	Lubricate Until Grease Can Be Seen

NOTE: TROLLEY WHEEL BEARINGS ARE LIFETIME LUBRICATED.

Preventive Maintenance Schedule

The periods between inspections will vary due to the wide range of duty cycles and operating conditions encountered with this type of equipment. The following inspection periods are based on average duty with single shift operation (40 hours per week) under normal environmental conditions. If the hoist is used in heavier applications or under adverse environmental conditions, it should be inspected more frequently.

When Replacement Parts Are Needed, Order Only YALE® Factory Engineered Parts

Yale®

Daily Inspection

Inspect the following items before operating hoist.

1. Controls: Check all controls and operating mechanism for improper operation.
2. Limit Clutch: Check limit clutch for improper operation. Run the upper and lower chain stop into the hoist at slow speed. A clutching noise may be heard when operating the hoist against the stops. This is normal in an overloaded or stalled condition.
3. Hooks: Check for cracks or deformation. The bottom hook must swivel freely. Check for damaged or missing safety latch. A bent or twisted hook indicates overloading or abuse of the unit. Other load bearing components of the hoist or trolley should be inspected if overloading is apparent or suspected.
4. Chain: Check for nicks, gouges, corrosion, twisted or distorted links.
5. Unusual Conditions: Excessive noise, oil leaks, etc. should be investigated.



CAUTION

DO NOT OPERATE THE HOIST IF IT IS FUNCTIONING IMPROPERLY OR DAMAGE IS NOTED.

Monthly Inspection

1. All items under daily inspection.
2. Chain: If chain binds, jumps, or is noisy, check for cleanliness and proper lubrication. If trouble persists, inspect chain for wear and stretch. See page 13.
3. Hooks: Replace hooks if the throat opening is in excess of maximum shown in Table 1, page 7, or if there is 10 degrees or more twist from normal plane of hook. Check hook retaining nuts or collar and means to secure them.
4. Load and idler pocket wheels or sprockets: Pocket wheels or sprockets which are worn should be replaced, as they can greatly reduce the life of the hoist chain.
5. Air Supply System: Check for leaks or loose connections.
6. Load Brake: Check the function of the load brake by lifting a light load, disconnecting the air line, removing the control cover, and manually opening the motor brake. The load may "creep" slowly while the motor brake is held open. This is normal. However, if the load falls to the floor the instant the motor brake is released, the load brake is not functioning and should be repaired. Replace the load brake assembly 6438664. See item (5) under RECOMMENDED SEQUENCE OF DISASSEMBLY, page 23.
7. Bearings: Check all bearings for noisy operation, which is an indication of wear.
8. Control Pendant: Check pendant for damage, leaks and proper operation.

When Replacement Parts Are Needed, Order Only YALE® Factory Engineered Parts

PREVENTIVE MAINTENANCE

Yale®

9. **Load Brake Backlash:** With no load on the hoist, check the backlash in the load brake by pulling on both the hook side and dead end side of the chain. If the amount of "free chain" that can be pulled back and forth through the hoist exceeds two full links, the backlash is excessive. Disassemble hoist per item (5) page 23, and check load brake disc wear. Replace the load brake assembly if discs are less than 1/16" thick. Adjust the brake backlash per "Important" note in item 1.d page 24 during reassembly.
10. **Lubricant:** Check the condition and level of the lubricant. The lubricant should be clear in color. Black color indicates a chemical change in the lubricant caused by excessive heat from the load brake which is in turn caused by heavy duty cycles. Lubricant that is black in color must be replaced to prevent shortened life of Drive components. If the level is low, check for leaks. Replace gaskets & seals as required. Lubricate chain and other points as required. See chart page 10.

⚠ CAUTION

FOR OPTIMUM LUBRICATION AND LOAD BRAKE COOLING, OIL LEVEL
MUST BE MAINTAINED AT THE LEVEL PLUG.

11. **Warning Labels:** Check for absence or illegibility of required warning labels and tags and replace if necessary.
12. **Supporting Structure of Trolley:** If used, should be checked for continued ability to support the imposed loads. Check for loose suspension or support bolts, axles, nuts, etc.
13. **Hardware:** Check for loose bolts, nuts and rivets.

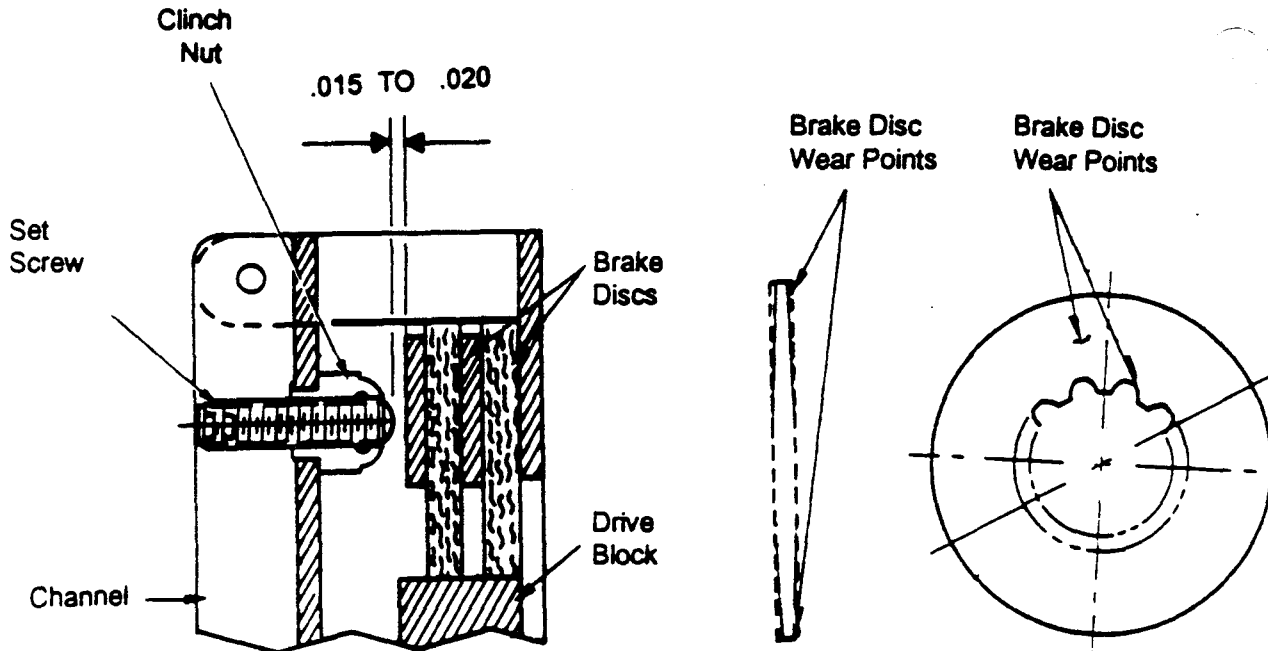

FIGURE 4.

Note: Inspection Record

The last pages of this manual are inspection check lists to be filled out and signed by the person making the monthly or annual inspections.

When Replacement Parts Are Needed, Order Only YALE® Factory Engineered Parts

Yale®

14. **Inspection Check List:**

Fill out inspection check list at back of this manual, sign, date, and file for future reference.

Annual Inspection

1. All items under daily and monthly inspection.
2. Hooks: Magnetic particle or other suitable crack detecting inspection should be performed if need is indicated by external appearance. Check for loose retaining nuts and collars.
3. Load Bearing Parts: Check for worn, cracked or distorted parts such as hook blocks, suspension housing, outriggers, clevises, yokes, suspension bolts, shafts, locking devices, and bearings on hoist (also on trolley if so equipped.)
4. Load Brake: Check load brake for worn discs. If either disc is worn 1/32" or more replace both discs. New discs measure 3/32".
5. Load Limiting Device: Check load limiting device with 175% of rated load.
6. Motor Brake: Check for excessive or uneven wear of the discs, and excessive play between the splines in the discs and the brake hub.
7. Load Chain: Carefully inspect the chain for wear between the links in the section of chain that most often passes over the pocket wheel. Check several links, as wear is seldom even from one link to another. See instructions below and on pages 18, 19 and 20.



CAUTION

THE CHAIN MUST BE REPLACED IF WEAR HAS INCREASED THE SPECIFIED GAGE LENGTH BEYOND THE MAXIMUM GIVEN IN TABLE BELOW. THE GAGE LENGTH SHOULD BE CHECKED ON PORTION OF CHAIN THAT NORMALLY PASSES OVER THE POCKET WHEEL, AND WITH A LOAD ON THE HOOK.

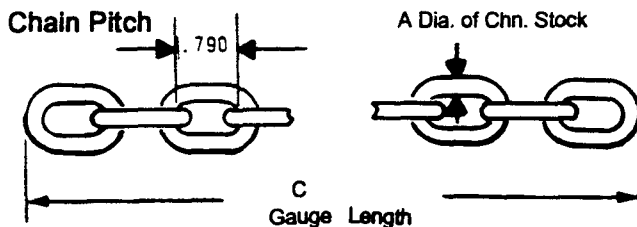

TABLE 3 CHAIN DIMENSIONS

MODEL	CHAIN IDENTIFICATION	A	NUMBER OF LINKS	MAX. C
All Capacities	Y* - 1K or Y1 - 1K	.312 INS	19	15.86



WARNING

WHEN REPLACING LOAD CHAIN, USE ONLY CHAIN STAMPED Y*-1K OR Y1-1K FOR PART NUMBER SEE PAGE 39, ITEM 21. INSTALL PER INSTRUCTIONS ON PAGE 17.

8. Chain Guide And Pocket Wheel: If the load chain is worn or stretched and requires replacing, also examine the pocket wheel and load chain guide and stripper. If these parts are worn they should be replaced to avoid damaging the new load chain and jamming of the chain. New link chain should be installed with weld on vertical link as shown in Figure 5 page 19.
9. Inspection Check List: Fill out inspection check list at back of this manual. Sign, date and file for future reference.

Function Testing

After repair of hoist, test with a light load for proper function. This hoist is equipped with a load limiting device. Load test unit with 100% of rated load, and check load limiting device with 175% of rated load. See item 5 of annual inspection instructions. (If no load bearing parts were repaired or altered, a normal load lifted may be used for test, and test of load limiting device may be omitted.) A written report of the test should be prepared by the person responsible and kept for future reference.

When Replacement Parts Are Needed, Order Only YALE® Factory Engineered Parts

Yale®

1. Hook Does Not Respond To Pendant Lever

<u>Possible Cause</u>	<u>Remedy</u>
(a) Power Failure.	(a) Check air supply source.
(b) Low air pressure	(b) Check air line pressure.
(c) Frozen exhaust muffler or motor.	(c) Excessive moisture in air line. Install dryer or drainer in air line.
(d) Motor brake not opening. (Motor will hum but not rotate.) Some amount of air is exhausting.	(d) Disconnect the hoist from the power source. Check the brake cylinder and control circuit. Replace if necessary.

2. Hook Raises But Will Not Lower, empty hook

<u>Possible Cause</u>	<u>Remedy</u>
(a) Malfunction of manifold valve piston.	(a) Check to see if upper piston is fully closed. Lubricate if necessary.

3. Hoist Will Not Lift The Load

<u>Possible Cause</u>	<u>Remedy</u>
(a) Excessive load.	(a) Reduce load to the capacity limit shown on the hoist nameplate.
(b) Defective motor.	(b) Examine the vanes, vane springs and housing for excessive wear or damaged parts. Replace as required.
(c) Worn load limit clutch.	(c) Follow the instructions under DISASSEMBLY (Note Paragraph u on page 24.) Replace the clutch hub assembly.
(d) Low air line pressure.	(d) Check air supply line and/or air compressor.
(e) Insufficient Lubrication	(e) Check air line oil and filter

When Replacement Parts Are Needed, Order Only YALE® Factory Engineered Parts

Yale®

4. Hook Does Not Stop Promptly

<u>Possible Cause</u>	<u>Remedy</u>
(a) Motor brake slipping	(a) Check for oil on brake discs. Check for proper oil level. Replace the gear case cover oil seal per instructions under RECOMMENDED SEQUENCE OF DISASSEMBLY, Paragraph (o) on page 23, and REASSEMBLY, Paragraph (g) on page 26. Check brake discs for uneven or excessive wear. Replace if necessary. See RECOMMENDED SEQUENCE OF DISASSEMBLY, Item 3, Paragraph (a), page 24 (b), page 25. Check brake mechanism for free operation.
(b) Load brake discs worn.	(b) Follow the instructions under preventive maintenance schedule, monthly inspection number 6, Load Brake: page 11.
(c) Manifold does not exhaust properly.	(c) Check pistons. Install manifold repair kit if necessary. See air flow diagram page 55.
(d) Sticky and/or worn piston.	(d) Lubricate piston with 10W motor oil. Check air line oiler. Replace piston if worn.

5. Motor Overheats Or Frozen

<u>Possible Cause</u>	<u>Remedy</u>
(a) Check air line oiler.	(a) Add oil.
(b) Defective vanes, vane springs and/or push rod.	(b) Install motor repair kit. See Page 57.
(c) Excessive moisture in air line.	(c) Drain air line and filter.

When Replacement Parts Are Needed, Order Only YALE® Factory Engineered Parts

TROUBLE SHOOTING GUIDE

Yale®

6. Hoist Is Noisy In Lowering Direction

<u>Possible Cause</u>	<u>Remedy</u>
(a) Load brake "chattering" due to improper lubricant.	(a) Change lubricant to nameplate specification.
(b) Defective roller clutch.	(b) Replace with Load Brake Assembly 6438664-00 under item 23, page 41.

7. Load Chain Jumps On Pocket Wheel

<u>Possible Cause</u>	<u>Remedy</u>
(a) Worn chain.	(a) To determine allowable wear, see preventive maintenance schedule, load chain page 13.
(b) Worn chain guide or Pocket wheel.	(b) Replace. Follow instructions under RECOMMENDED SEQUENCE OF DISASSEMBLY, Paragraph x on page 24.
(c) Incorrect chain.	(c) Replace with correct chain See page 13.

8. Air Motor Trouble Shooting

Note: See Air Motor Disassembly and Repair Kit Installation Page 57, in Back of Manual.

When Replacement Parts Are Needed, Order Only YALE® Factory Engineered Parts

Yale®

Instructions For Installing New Chain

 CAUTION

DO NOT REMOVE THE OLD CHAIN FROM THE HOIST;
THIS IS THE LAST STEP.

- (a) For 1/2 and 1 Ton Units: Remove the socket head screw from the bottom block. Remove bolt from chain dead end at lower crosshead. Remove chain stop.
For 2 Ton Units: Remove socket head suspension screw holding anchor block, drive out anchor pin. Pull chain thru bottom block. Remove bolt from chain dead end at lower crosshead. Remove chain stop.
For 3 Ton Units: Remove shoulder screw in top of bottom block. Pull chain thru idler sheave and bottom block. Remove bolt from dead end at lower crosshead. Remove chain stop.
- (b) Cut a link from the end of the old chain **WITHOUT REMOVING THE CHAIN FROM THE HOIST.**

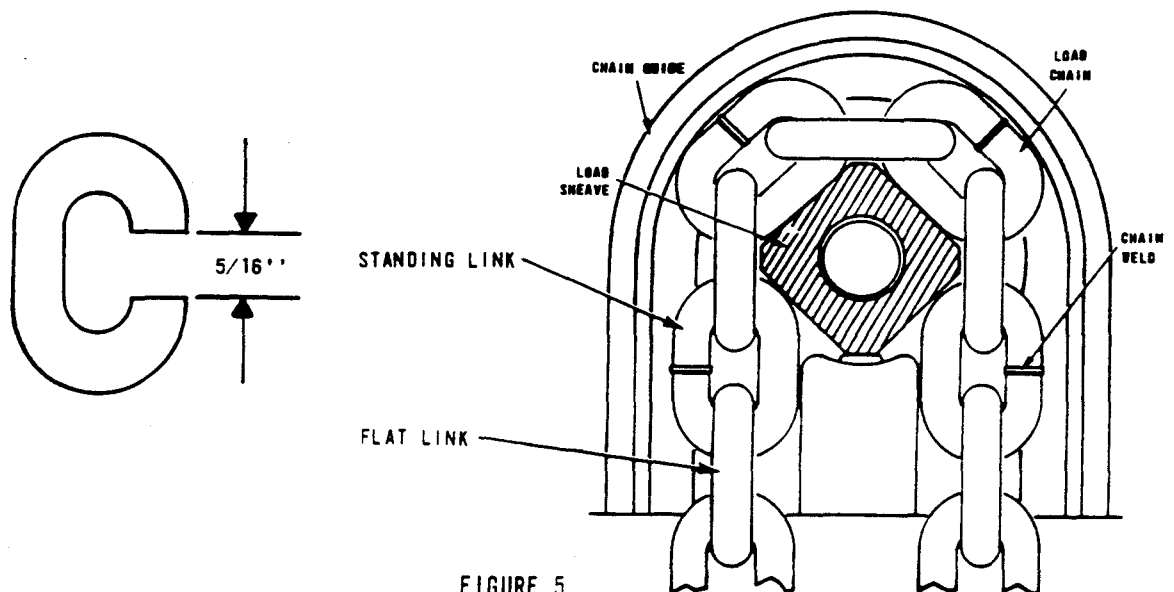

FIGURE 5.

- (c) Notch the links as shown in the illustration above being careful not to distort it in any way. It must pass over the pocket wheel without binding. The chain is hard. An abrasive wheel will be needed to cut it.
- (d) Lubricate the new chain per instructions and lubrication cart on page 10.
- (e) Connect the new chain to the old using the notched link. Be sure the welds of the standing links (links turned perpendicular to the sheave) face away from the driven pocket wheel. On 1/2, 1 & 2 ton units the first link of the new chain must go on flat. On 3 ton units first link of new chain must go on standing. Use 2 notched links if necessary. See Figure 5 above and Figure 6, Page 18.

When Replacement Parts Are Needed, Order Only YALE® Factory Engineered Parts

DISASSEMBLY

Yale®

Guide Sheet For Installing Chain

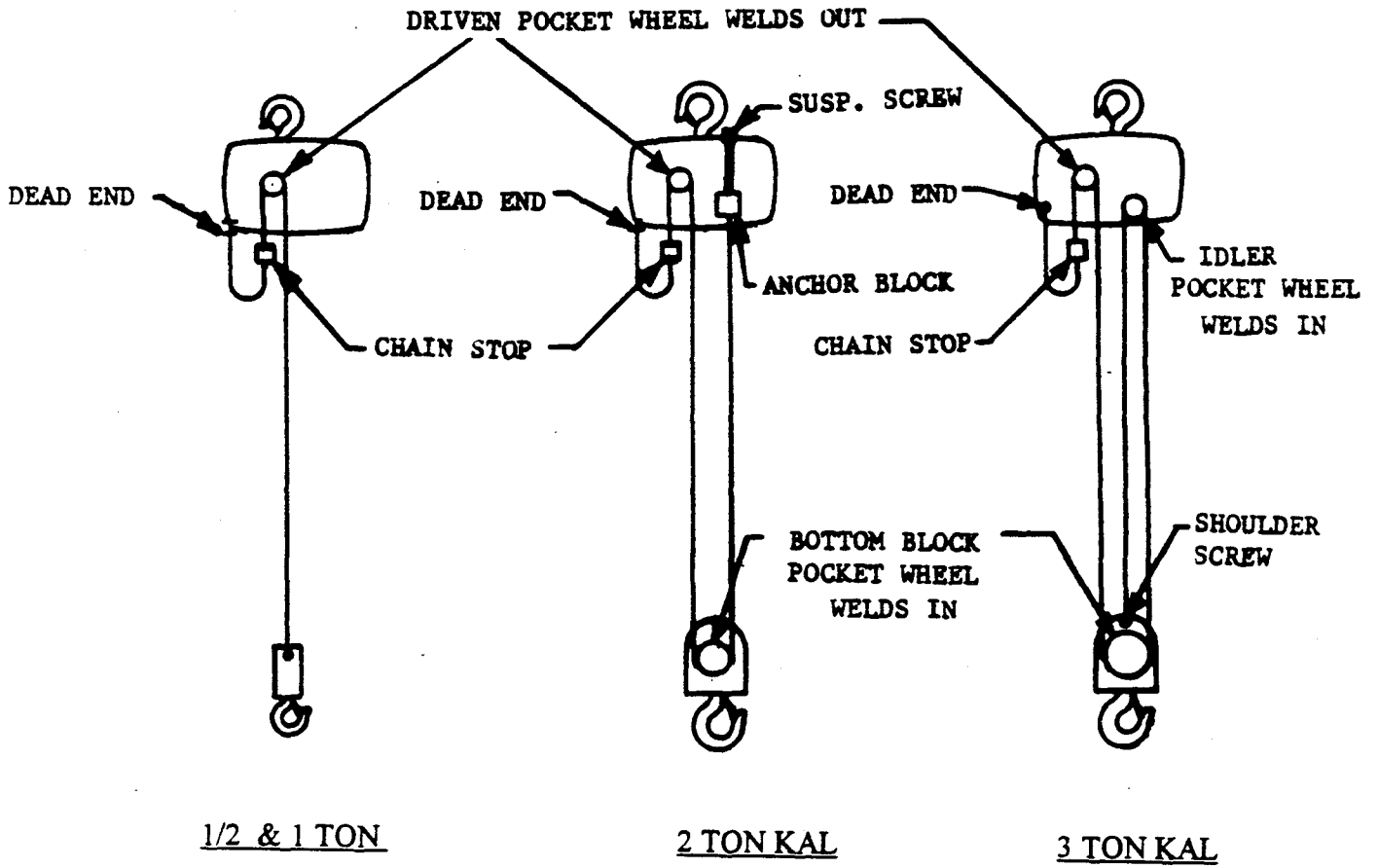

FIGURE 6

When Replacement Parts Are Needed, Order Only YALE® Factory Engineered Parts

Yale®

- (f) Carefully energize the hoist paying off the old chain and feeding on the new chain.
- (g) For 1/2 and 1 Ton Units: Assemble chain to bottom block with the socket head screw and retaining band. Replace chain stop at least 8 links from dead end of chain. Fasten dead end to lower crosshead. Do not twist chain.
For 2 Ton Units: Work chain over bottom block sheave with the chain welds on "Standing Links" toward the sheave. Start with "Flat" link and be sure chain is not twisted. Install chain end to anchor block with anchor pin. **BE SURE CHAIN IS NOT TWISTED.** Install anchor block to hoist with socket head suspension screw, be sure the top lip of anchor block extends past end of bottom crosshead. Socket head screw must be torqued to 40-50 Ft. Lbs. Replace chain stop at least 8 links from dead end of chain. Fasten dead end of chain to bottom crosshead.
Be sure chain is not twisted.
For 3 Ton Units: Work chain over bottom block sheave with the chain welds on "Standing Links" toward the sheave. Start with "Standing Link." Be sure chain is not twisted. Work chain over idler pocket wheel from side away from center line of hoist. Chain welds on "Standing Link" must be toward the pocket wheel. **BE SURE CHAIN IS NOT TWISTED.** Pull end through and fasten to top of bottom block with shoulder screw. Be sure chain is not twisted. Replace chain stop at least 8 links from dead end of chain. Fasten dead end to bottom crosshead. Be sure chain is not twisted.

When Replacement Parts Are Needed, Order Only YALE® Factory Engineered Parts

DISASSEMBLY

Yale®

1. Recommended Sequence Of Disassembly

Before doing any maintenance work on the hoist read the following instructions thoroughly. Refer to the replacement parts section for part identification.

TO COMPLETELY DISASSEMBLE THE HOIST: Follow the disassembly procedures in the order listed.

TO DISASSEMBLE ANY ONE SPECIFIC PART OF THE HOIST: Follow the instructions for that specific section.

- (a) Disconnect the dead end of the chain from the hoist (both ends on 2 Ton models), and remove the chain stop.
- (b) Run the hoist in the lowering direction to remove the chain. If air was disconnected before the chain was removed, wait until step (v) to remove chain.
- (c) If it is necessary to separate the bottom block from the chain, on 1/2 and 1 ton hoists, remove the socket head screw from the bottom block. On 2 ton models, simply pull the chain through the block. On 3 ton models, remove shoulder screw at top of bottom block and pull chain thru block and idler sheave.
- (d) If it is necessary to remove the hook from the block, on 1/2 and 1 ton hoists, remove the 1/4 inch socket head locking screw from the bottom block. On 2 and 3 ton models, remove the two (2) 3/8 inch hex head bolts and separate the block halves, drive out roll pin, unscrew hook nut and remove bearing.



CAUTION

BEFORE CONTINUING FURTHER WITH THE DISASSEMBLY PROCEDURES, CUT OFF ALL POWER TO THE HOIST BY DISCONNECTING THE AIR SUPPLY LINE.

- (e) The hoist should now be removed, if possible, from the working area and placed on a maintenance bench for further disassembly.



CAUTION

NEVER DISASSEMBLE THE HOIST IN DIRTY SURROUNDINGS, NOR ALLOW DIRT, GRIT OR ANY OTHER FOREIGN MATERIAL TO GET ON THE WORKING PARTS OF THE HOIST OR INTO THE WORKING AREAS OF THESE PARTS.

- (f) Drain the oil from the hoist by removing the 1/2 inch hex socket drain plug from the bottom of the gear case.

NOTE:

A convenient way to hold the unit for disassembly is to invert the unit and clamp the top hook or suspension lug in a vise.

When Replacement Parts Are Needed, Order Only YALE® Factory Engineered Parts

Yale®

- (g) Loosen the four (4) slotted 10-24 control cover screws and remove the control cover. Torque to 20-30 in/lbs at reassembly.
- (h) Disconnect 1/4 inch plastic tubing from the three way control valve and two way check valve.
- (i) Disconnect the pendant support cable and remove from the housing.
- (j) Remove two (2) Philip head screws and remove the control cylinder.
- (k) Remove two (2) 8-32 Philip head screws and the control mounting plate.
- (l) Remove the motor brake assembly. **DO NOT REMOVE THE SPLINED BRAKE DISC DRIVE BLOCK AT THIS TIME.**
- (m) Disconnect the 1/4 inch plastic tubing from the (3) three elbows on the air manifold. Disconnect the pendant hoses from the manifold. Remove manifold from motor by removing two (2) socket head screws.
- (n) Remove the four (4) 10-32 bolts from the flange of the motor and carefully remove the motor. The coupling sleeve should come out with the motor shaft; if not, remove the coupling sleeve next. Torque motor bolts to 25-30 in/lbs and manifold mounting screws to 90-120 in/lbs at reassembly.
- (o) Remove the six (6) 1/4-20 hex head screws from the gear case cover and carefully pull the cover back together with the pinion shaft. (If the gear case cover oil seal is to be reused, it is important that the shaft and cover be pulled together to prevent damage to the seal.) As the shaft is removed, it must pass through a second oil seal in the end of the sheave shaft. Keep the shaft straight and centered in the sheave shaft until it is free of the hoist. If the cover gasket is not torn or otherwise damaged, it may be reused. Torque gear case cover screws to 115-125 in/lbs at reassembly.
- (p) Remove the retaining ring and brake drive block from the pinion shaft. If the gear case cover oil seal is to be reused, cover the shaft serration with tape or some other means before pulling the shaft through the seal.
- (q) Remove the retaining ring of the first reduction gear and pull off the gear.
- (r) Remove the three (3) 10-24 hex head bearing retaining screws and pull out the second reduction pinion.
- (s) Remove the two (2) allen screws locking the sheave shaft nut, and remove the nut (left hand thread.) All shaft components will now slide off.

When Replacement Parts Are Needed, Order Only YALE® Factory Engineered Parts

DISASSEMBLY

Yale®

- (t) Do not disassemble the load brake assembly. This is a Factory Assembly. Individual spare parts cannot be obtained separately. See page (39), Item (24) for further information.
- (u) Do not disassemble the overload clutch and second reduction gear assembly. This is a factory calibrated unit that may be damaged if disassembled. Parts for the clutch assembly cannot be obtained separately. See page (39), Item (22) for detailed information.
- (v) If the chain was not removed from the hoist at step (b), remove it now by turning the sheave shaft by hand and feeding the shortest end of the chain straight into the guide.
- (w) Remove the two (2) 1/2-13 allen socket head suspension bolts, and the top and bottom crossheads. See pages 25 through 31 for reassembly.
- (x) Remove the three (3) 10-20 hex head sheave shaft bearing retaining screws. Pull the chain guide halves out of the housing far enough to retract the stripper from the sheave then pull the sheave shaft from the housing being careful not to damage the oil seal if it is to be reused. The chain guide halves can now be removed from the housing.
- (y) This completes the disassembly. UNDER NO CIRCUMSTANCES SHOULD THE THREE (3) TAMPER PROOF SCREWS THAT JOIN THE HOUSING HALVES BE REMOVED. The halves mate with an interference fit and were permanently joined by a hydraulic press before machining. If the halves are separated, the dimensional accuracy of the housing will be destroyed.

2. To Remove The Motor And Manifold

- (a) Cut off all power to the hoist by disconnecting the air feed line.
- (b) Do not allow dirt, grit or any other foreign material to get on the working parts of the hoist or into the working areas of these parts.
- (c) Follow steps (e), (g), (h), (i), (m), and (n) under RECOMMENDED SEQUENCE OF DISASSEMBLY.

3. To Remove The Motor Brake

- (a) Follow steps (a) and (b) above and steps (e) and (g) under RECOMMENDED SEQUENCE OF DISASSEMBLY.

When Replacement Parts Are Needed, Order Only YALE® Factory Engineered Parts

Yale®

- (b) Disconnect the 1/4 inch plastic tubing to the motor brake cylinder and remove the four (4) screws holding the brake to the gear case cover. To replace the brake discs it is necessary only to remove the two (2) upper shoulder screws.

4. To Remove The Gearing Or Load Limiting Clutch

- (a) Follow steps (a) and (b) under TO REMOVE THE MOTOR.
- (b) Follow steps (e), (f), (g), (j), (k), (l), (o), (p), (q), (r), (s), (t), and (v).

5. To Remove The Load Brake

- (a) Follow steps (a) and (b) under TO REMOVE THE MOTOR.
- (b) Follow steps (e), (f), (g), (h), (o), (q), (r), (s), (t) and (u) under RECOMMENDED SEQUENCE OF DISASSEMBLY.

6. To Remove The Driven Pocket Wheel And Chain Guide

- (a) Follow steps (a), and (b) under to remove the load brake.
- (b) Follow steps (v), (w), (x) and (y) under RECOMMENDED SEQUENCE OF DISASSEMBLY.

7. To Remove The Top Hook Or Lug

- (a) Follow steps (a) and (b) under TO REMOVE THE MOTOR.
- (b) Follow steps (e) and (w) under RECOMMENDED SEQUENCE OF DISASSEMBLY.

8. To Remove The Bottom Hook

- (a) Follow step (d) under RECOMMENDED SEQUENCE OF DISASSEMBLY.

When Replacement Parts Are Needed, Order Only YALE® Factory Engineered Parts

REASSEMBLY

Yale®

9. To Remove The Gear Case Cover

- (a) Follow step (a) under TO REMOVE THE LOAD BRAKE.
- (b) Follow steps (e), (f), (g), (j), (l), (o), and (p) under RECOMMENDED SEQUENCE OF DISASSEMBLY.

1. Reassembly

- (a) Reverse the procedure for disassembly replacing all worn or damaged parts.
- (b) First install the pocket wheel shaft and chain guide halves. Then the top and bottom crossheads. See page 25 through 31 for crosshead assembly.
- (c) As in disassembly, invert the unit and clamp the top hook or lug in a vise.
- (d) With the unit inverted, feed the chain straight into the guide rotating the pocket wheel shaft by hand. Be sure the welds of the "standing" links face away from the sheave. See Figure 5, page 17.
IMPORTANT: When installing the left-hand threaded retaining nut at the end of the pocket wheel shaft be sure the output gear-clutch assembly is screwed all the way onto the shaft to allow the nut to bottom on the shaft shoulder. Back off the nut as little as possible to line up the locking screw holes.



CAUTION

BE SURE THE TWO (2) LOCKING SCREWS HAVE LOCKWASHERS.

- (e) When the nut is adjusted properly, the output gear will rotate independently of the chain sheave through an arc not exceeding three gear teeth.
- (f) Be sure all fasteners have lockwashers.
- (g) Remember: Oil seals are delicate, easily distorted in installation and easily cut by shaft serration's and burrs. Cover serration's and lubricate seals when assembling.
- (h) See the PREVENTIVE MAINTENANCE SCHEDULE section for proper motor brake adjustment, page 10.
- (i) Be sure to replace the chain stop before operating the hoist. THE CHAIN STOP ON THE DEAD END OF THE CHAIN MUST BE AT LEAST EIGHT (8) LINKS FROM THE CHAIN END.
- (j) Fill gear case to level plug only with lubricant specified under "LUBRICATION", PAGE 10. (Approx. 2 1/4 pints required.)

When Replacement Parts Are Needed, Order Only YALE® Factory Engineered Parts

K - Series Chain Hoist TOP AND BOTTOM CROSSHEAD ASSEMBLY

Crosshead assembly procedures are slightly different for each hoist rating. The proper procedure **MUST** be followed to insure proper hoist operation.

The Top Crosshead Assembly consists of the Crosshead and one of the illustrated suspensions.

Note: (Rotating is standard.)

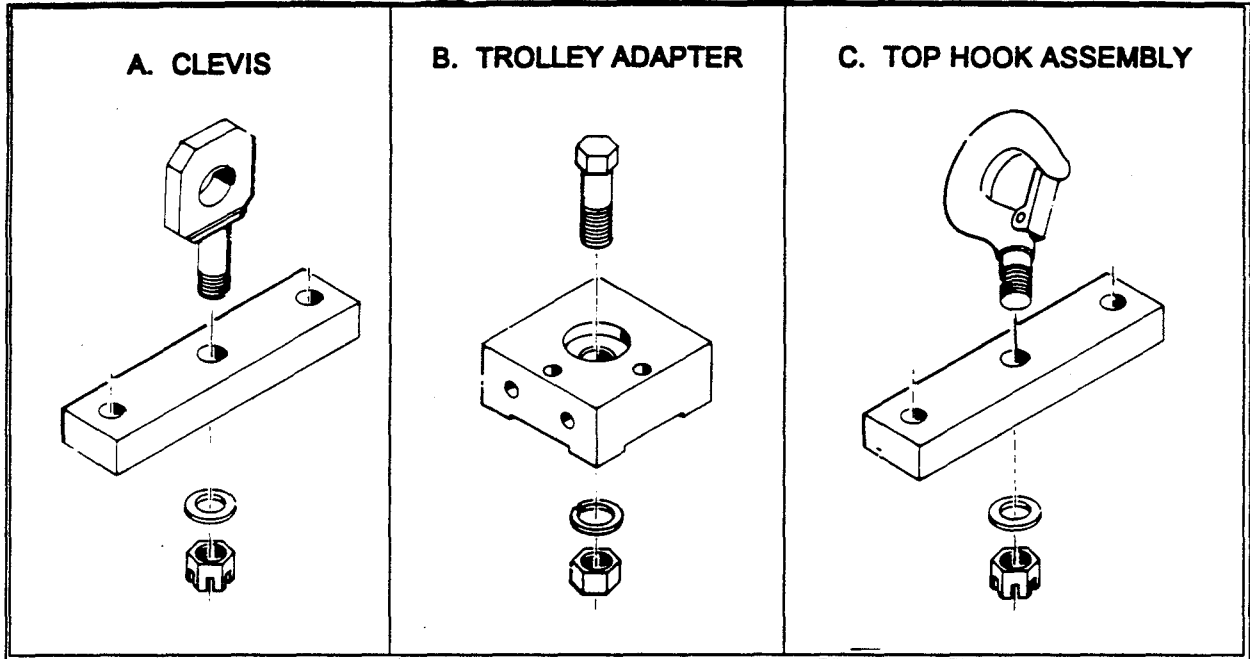

The Bottom Crossheads for each hoist rating are illustrated below:

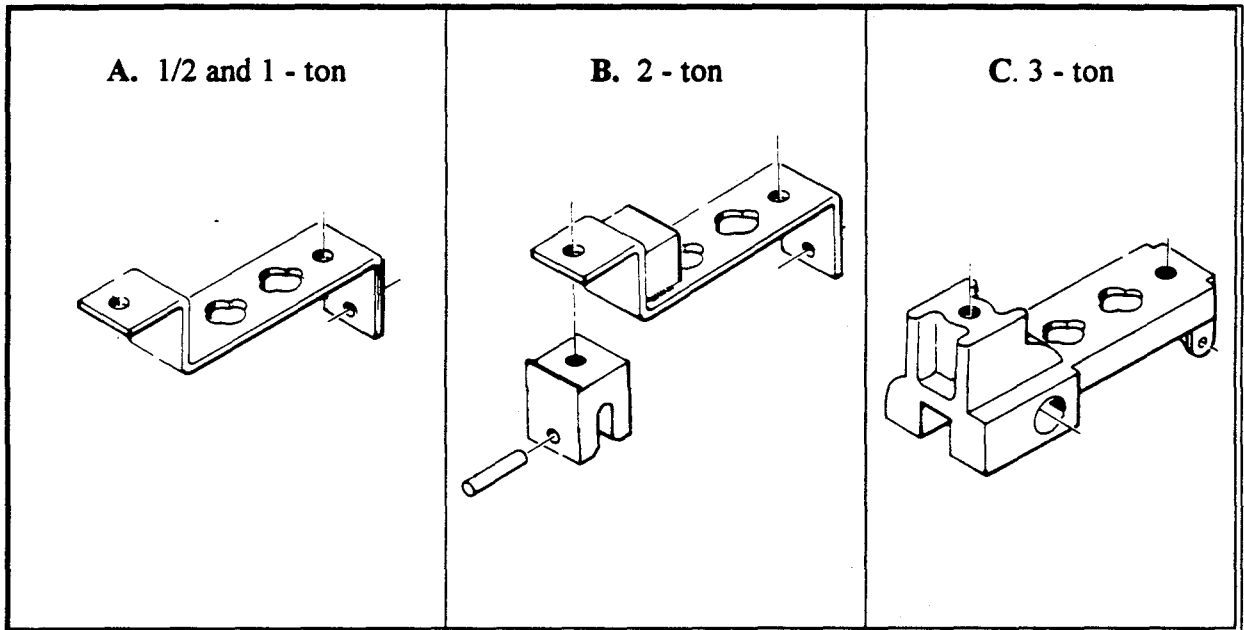

Bottom Crosshead Assembly procedures are described on the following pages. The hoist should be placed on its side to facilitate proper assembly. Wood blocks may be used to hold hoist in position during assembly.

(KAL ONLY) For spark resistant units, follow instructions for next higher rated unit. For example, if nut is a 1-Ton spark resistant hoist, follow procedures listed for the 2-ton unit.

When Replacement Parts Are Needed, Order Only YALE® Factory Engineered Parts

ASSEMBLY PROCEDURE 1/2 and 1 TON units with HOOK or CLEVIS

Note: (Rotating is standard.)

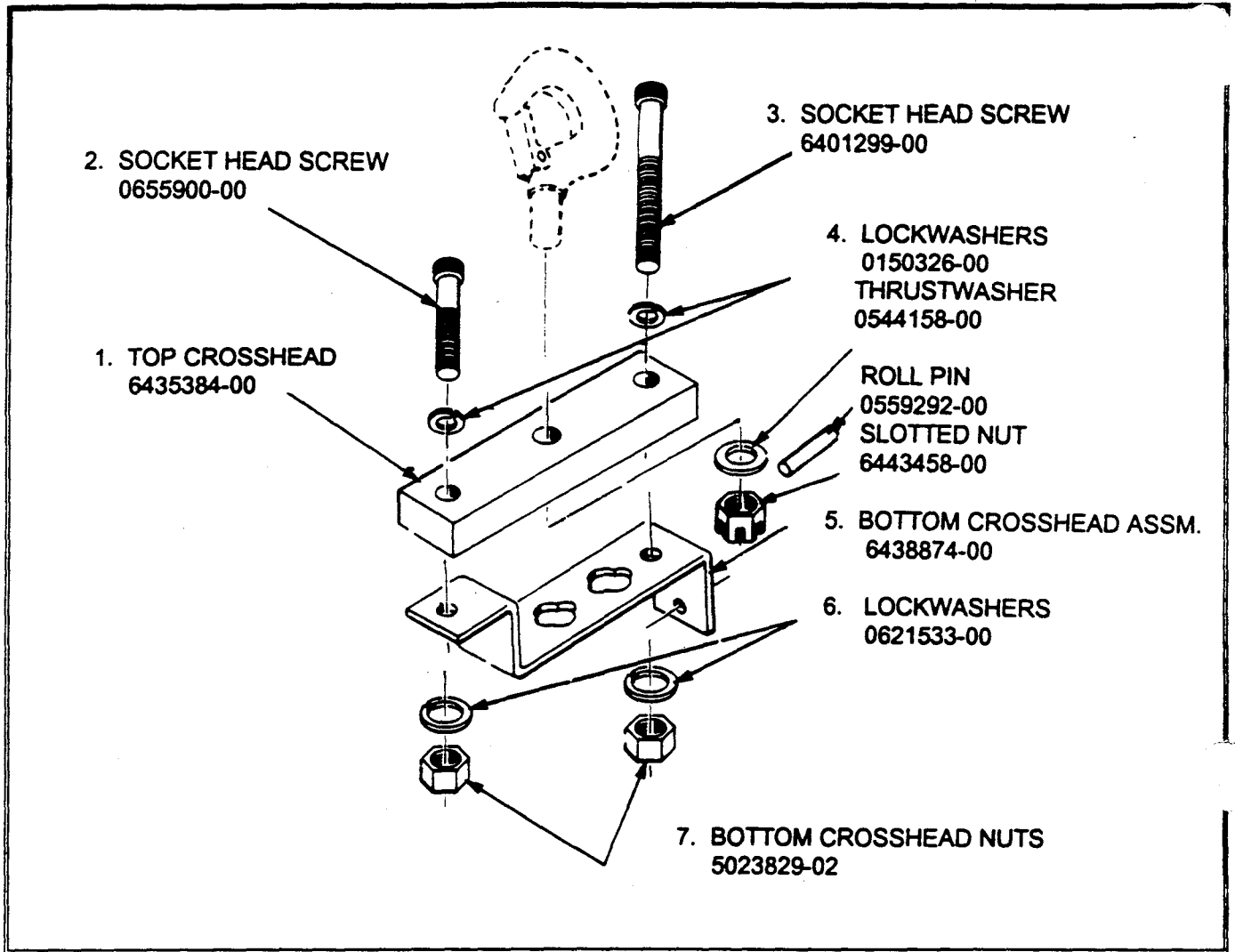

1. Assemble hook to top crosshead (1) with Counterbored holes on hook side (top). Assemble thrustwasher, slotted nut and roll pin. Allow hook to swivel freely.
2. Place Top Crosshead Assembly (1) with Socket Head Screws and Lockwashers (4) in position.
3. Place Bottom Crosshead (5) in position.
4. Assemble Lockwashers (6) and Bottom Crosshead Nuts (7). **CAUTION:** Care should be taken to insure that the nuts do not become cross threaded—they should turn freely until snugged.
5. After nuts are hand-snugged, place Allen Wrench in socket head screw then tighten Bottom Crosshead Nuts to 40 to 50 ft-lb. Torque

When Replacement Parts Are Needed, Order Only YALE® Factory Engineered Parts

ASSEMBLY PROCEDURE 2 TON unit with HOOK or CLEVIS

NOTE: (Rotating is standard.)

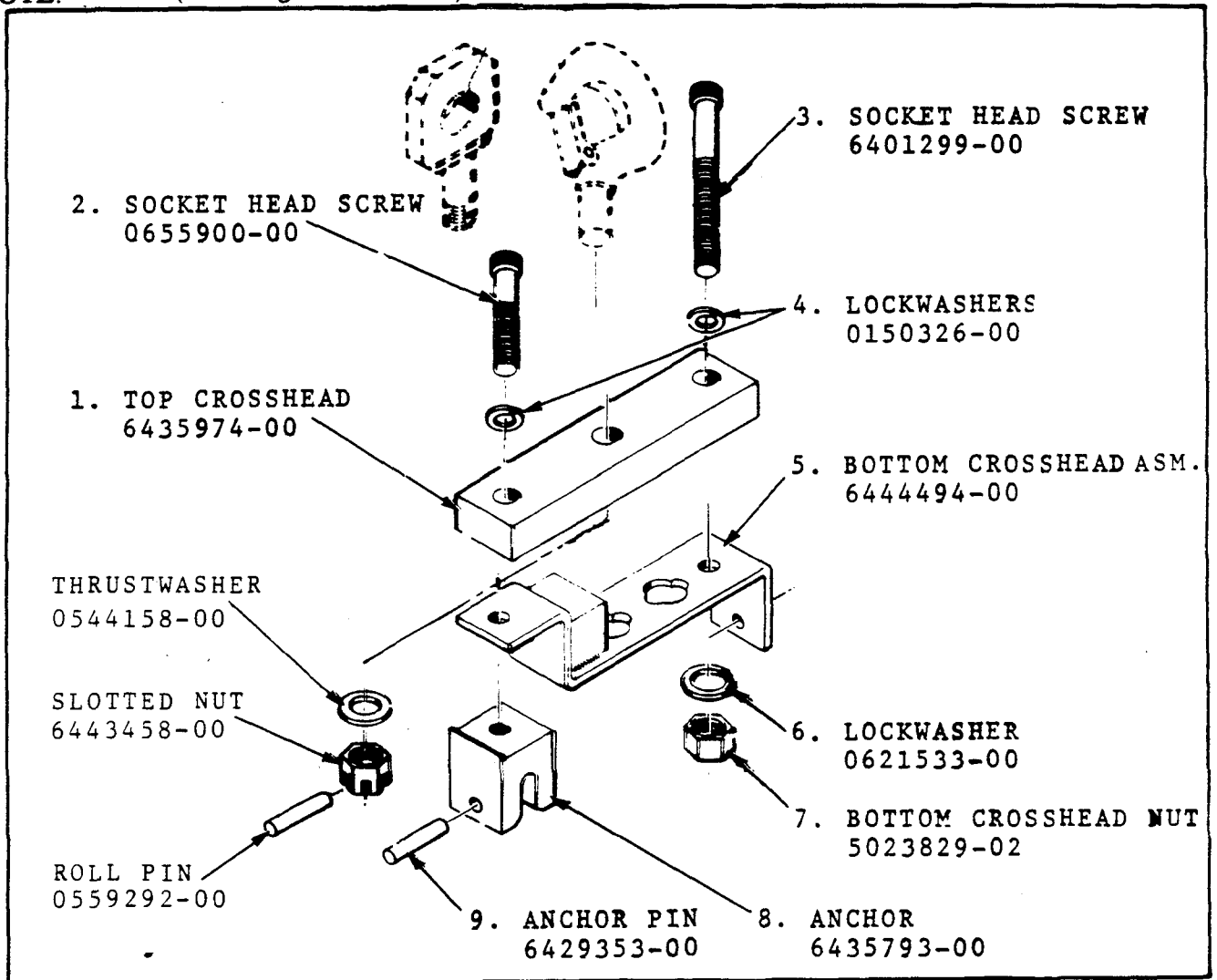

1. Assemble hook to top crosshead (1) with Counterbored holes on hook side (top). Assemble thrustwasher, slotted nut and roll pin. Allow hook to swivel freely.
2. Place Top Crosshead Assembly (1) with socket head screws (2 & 3) and Lockwashers (4) in position.
3. Place Bottom Crosshead (5) in position.
4. Assemble Lockwasher (6) and Bottom Crosshead Nut (7) to Socket Head Screw (3).
CAUTION: Care should be taken to insure that the nut does not become cross threaded—it should turn freely until snugged.
5. Assemble chain to anchor (8) with anchor pin (9).
6. Assemble anchor (8) to Socket Head Screw (2) by turning the screw with an Allen Wrench and aligning the anchor to prevent crossthreading. The anchor should be seated against the Bottom Crosshead before final torque.
7. Tighten both Socket Head Screws to 40 to 50 ft.-lb. Torque

When Replacement Parts Are Needed, Order Only YALE® Factory Engineered Parts

ASSEMBLY PROCEDURE 3 TON unit with HOOK OR CLEVIS

NOTE: (Rotating is standard.)

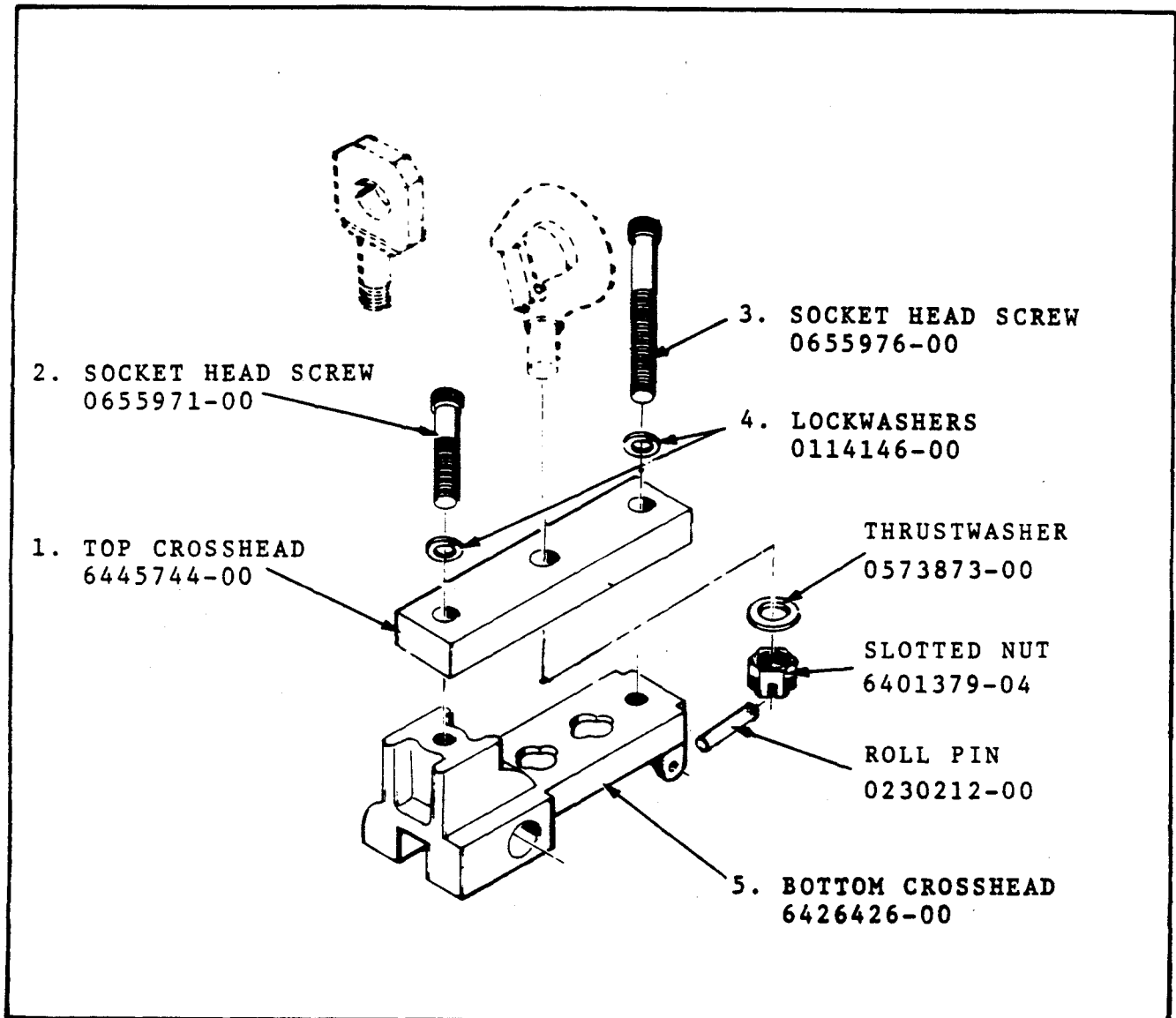

1. Assemble hook to top crosshead (1) with Counterbored holes on hook side (top). Assemble thrustwasher, slotted nut and roll pin. Allow hook to swivel freely.
2. Place Top Crosshead Assembly (1) with Socket Head Screws (2 & 3) and Lockwashers (4) in position.
3. Place assembled Bottom Crosshead in position.
4. Assemble Bottom Crosshead (5) to Socket Head Screws (2 & 3) by turning the screws with an Allen Wrench and aligning the crosshead to prevent cross threading. The crosshead must be seated against the housing before applying final torque.
5. Tighten both Socket Head Screws to 40 to 50 ft.-lb. Torque.

When Replacement Parts Are Needed, Order Only YALE® Factory Engineered Parts

ASSEMBLY PROCEDURE 1/2 AND 1-TON units - Lug Mounted

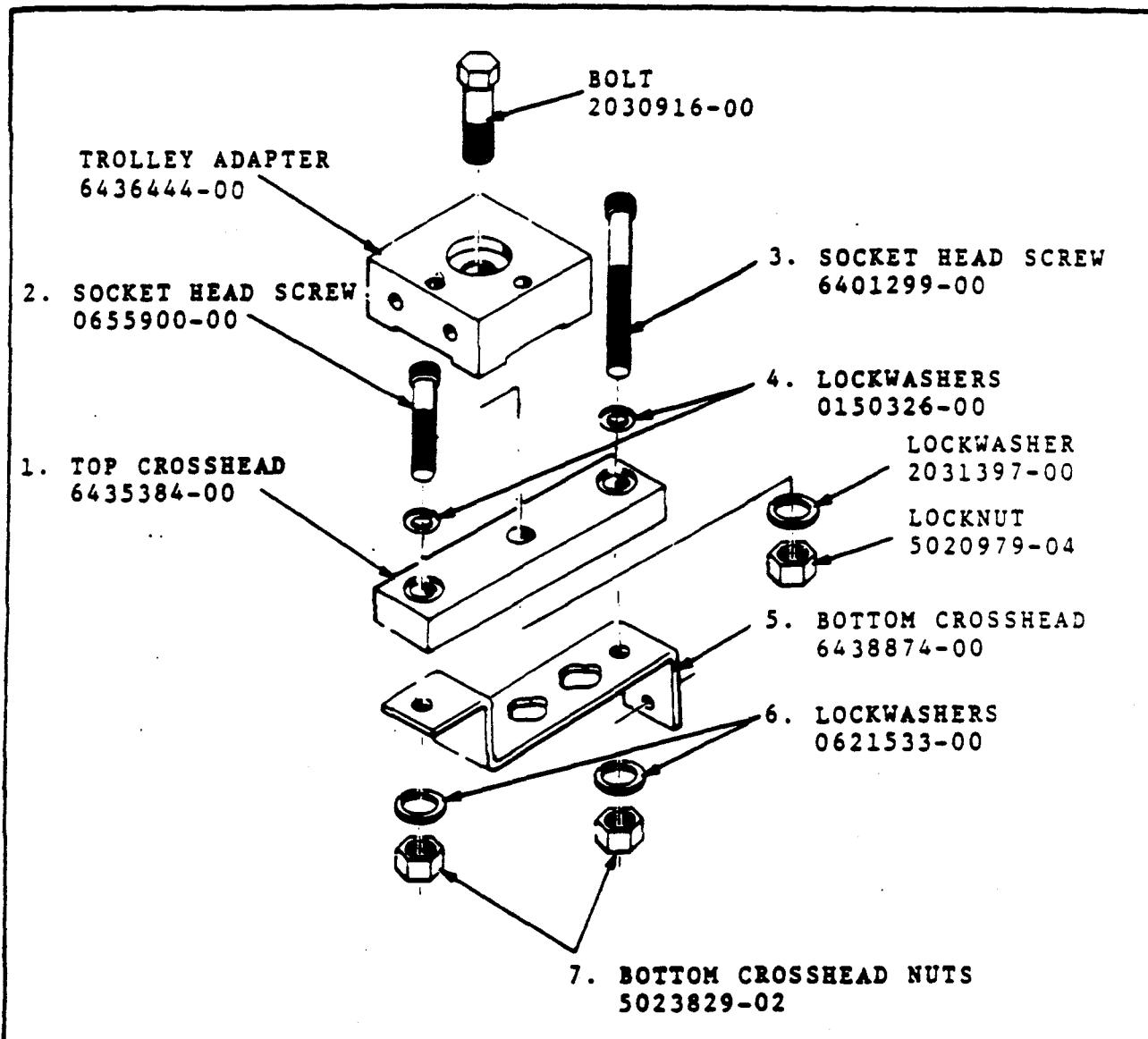

1. Assemble trolley adapter to top crosshead (1) on side with Counterbored holes. Be sure trolley mounting holes are oriented for proper trolley mounting, assemble bolt, lockwasher & locknut, tighten locknut to 150 - 160 ft./lbs. torque.
2. Place Top Crosshead Assembly (1) with Socket Head Screws (2 & 3) and Lockwashers (4) in position.
3. Place Bottom Crosshead (5) in position.
4. Assemble Lockwasher (6) and Bottom Crosshead Nuts (7). CAUTION: Care should be taken to insure that the nuts do not become cross threaded--they should turn freely until snuged.
5. After nuts are hand-snugged, place Allen Wrench in socket head screw then tighten Bottom Crosshead Nuts to 40 to 50 ft-lb.

When Replacement Parts Are Needed, Order Only YALE® Factory Engineered Parts

ASSEMBLY PROCEDURE 2 TON unit - Lug Mounted.

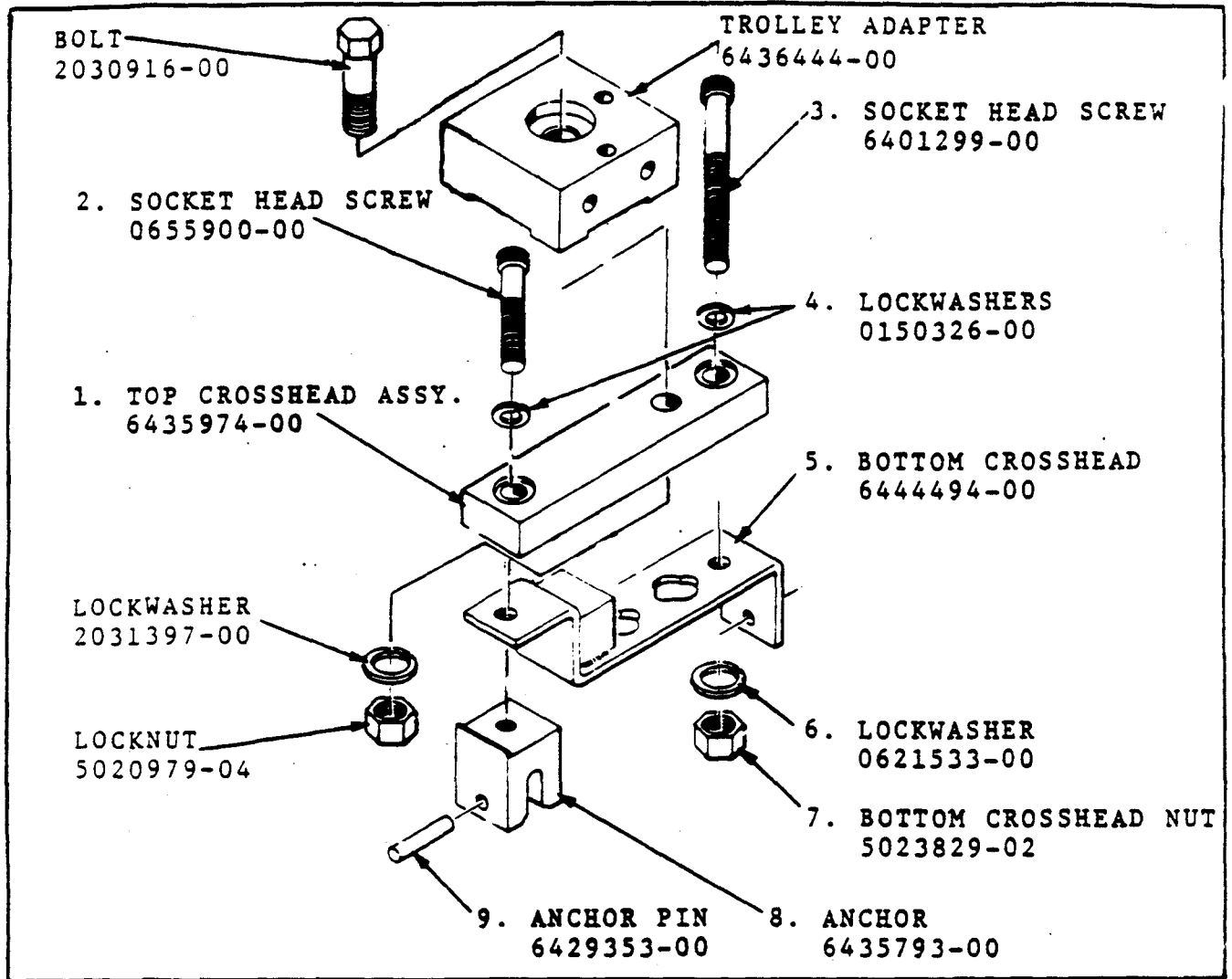

1. Assemble long socket head screw (3) and lockwasher (4) in near hole of crosshead (1) in countersunk side. Assemble trolley adapter with trolley mounting holes properly oriented for trolley mounting and through hole over socket head screw to allow allen wrench access. Assemble lockwasher, bolt and locknut. Tighten locknut to 150 to 160 ft./lbs. torque.
2. Place Top Crosshead Assembly (1) with socket head screw (2) and Lockwasher (4) in position.
3. Place Bottom Crosshead (5) in position.
4. Assemble Lockwasher (6) and Bottom Crosshead Nut (7) to Socket Head Screw (3). **CAUTION:** Care should be taken to insure that the nut does not become cross threaded— it should turn freely until snuged.
5. Assemble chain to anchor (8) with anchor pin (9).
6. Assemble Lockwasher (8) to Socket Head Screw (2) by turning the screw with an Allen Wrench and aligning the anchor to prevent crossthreading. The anchor should be seated against the Bottom Crosshead before final torque.
7. Tighten both Socket Head Screws to 40 to 50 ft.lb. torque.

When Replacement Parts Are Needed, Order Only YALE® Factory Engineered Parts

ASSEMBLY PROCEDURE 3 TON unit - Lug Mounted.

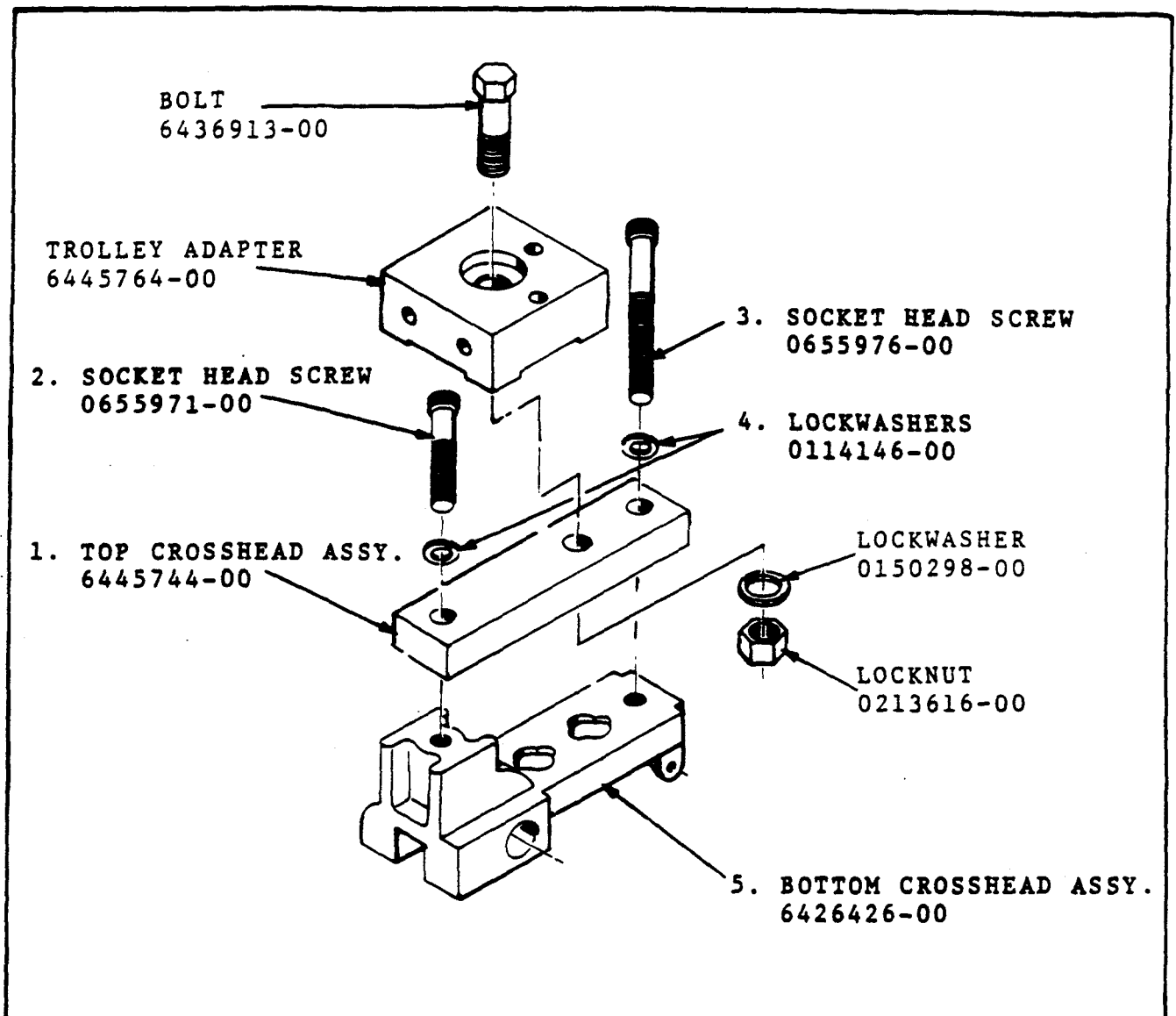

1. Assemble long socket head screw (3) and lockwasher (4) in near hole of crosshead (1) in Counterbored side. Assemble trolley adapter with trolley mounting holes properly oriented for trolley mounting and through hole over socket head screw to allow allen wrench access. Assemble lockwasher, bolt and locknut. Tighten locknut to 190 to 200 ft./lbs. torque.
2. Place Top Crosshead Assembly with Socket Head Screw (2) and Lockwasher (4) in position.
3. Place assembled Bottom Crosshead in position.
4. Assemble Bottom Crosshead (5) to Socket Head Screws (2 & 3) by turning the screws with an Allen Wrench and aligning the crosshead to prevent cross threading. The crosshead must be seated against the housing before applying final torque.
5. Tighten both Socket Heat Screws to 40 to 50 ft-lb.

When Replacement Parts Are Needed, Order Only YALE® Factory Engineered Parts

REPAIR PARTS

RECOMMENDED SPARE PARTS FOR ONE YEAR

ITEM	DESCRIPTION	CAPACITY	PART NUMBER	QTY.
1	HOOK LATCH KIT	1/2 TON	0669400-00	1
		1 TON	0669402-00	1
		2 TON	0669404-00	1
		3 TON	0669406-00	
2	MOTOR REPAIR KIT	1/2, 1 & 2 TON	6453788-00	1
3	MANIFOLD REPAIR KIT	1/2, 1 & 2 TON	6416092-00	1
4	SEAL & GASKET KIT	1/2, 1 & 2 TON	6410282-00	1
5	RETAINING RING	1/2, 1 & 2 TON	6401409-02	1
6	PIN	1/2, 1 & 2 TON	6401999-01	1
7	LUBRICANT (THREE CANS)	1/2, 1 & 2 TON	6496850-00	-
8	BEARING & CAP ASSEMBLY	3 TON	6491450-00	1

When Replacement Parts Are Needed, Order Only YALE® Factory Engineered Parts

Yale® Hoists

BOTTOM BLOCK ASSEMBLIES

S1 REEVED

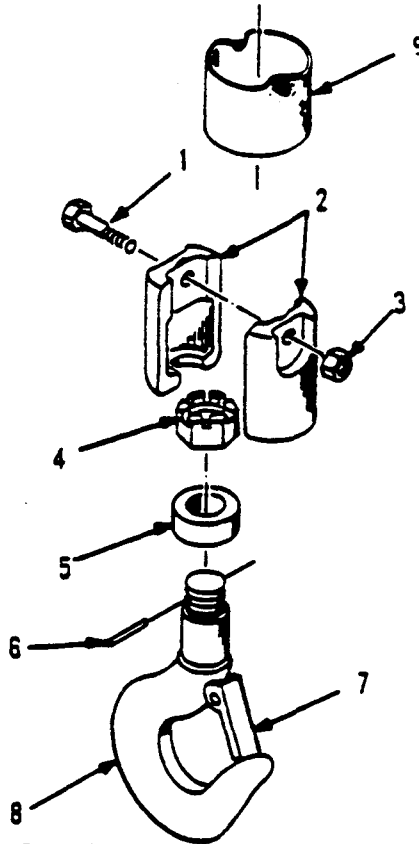

FIGURE 7.

BOTTOM BLOCK ASSEMBLY								
ITEM NO.	STD. HOOKS		BRONZE HOOKS		BULLARD HOOKS		DESCRIPTION	QTY.
	1/2 TON	1 TON	1/2 TON	1 TON	1/2 TON	1 TON		
1	642539200	642596200	642541200	642598200	642543200	642600200	SOCKET HD. SCREW	1
2	642895100	642896100	642895100	642896100	642895100	642896100	BLOCK HALF	2
3	642017100	642039100	642017100	642039100	642017100	642039100	LOCKNUT	1
4	015015200	015015300	015015200	015015300	015015200	015015300	SLOTTED NUT	1
5	010666300	065267300	647204400	065267300	010666300	065267300	THRUST BEARING	1
6	015122100	015122200	015122100	015122200	015122100	015122200	ROLL PIN	1
7	059989100	500409902	059989100	500409902	051191400	500409902	LATCH KIT	1
8	066940000	066940200	646255800	646254800	**	**	HOOK ASM	1
9	642540200	642595202	642542200	642597200	642544200	642599201	RETAINER BAND	1
	645640100	645671100	645670100	645671100	645670100	645671100		

** BULLARD HOOKS DO NOT REQUIRE LATCH KITS

*** INCLUDES 4, 6, AND 7

When Replacement Parts Are Needed, Order Only Yale® Factory Engineered Parts

REPAIR PARTS

Yale®

KAL - Series 2 Ton
Bottom Block Assembly
S2 Reeved

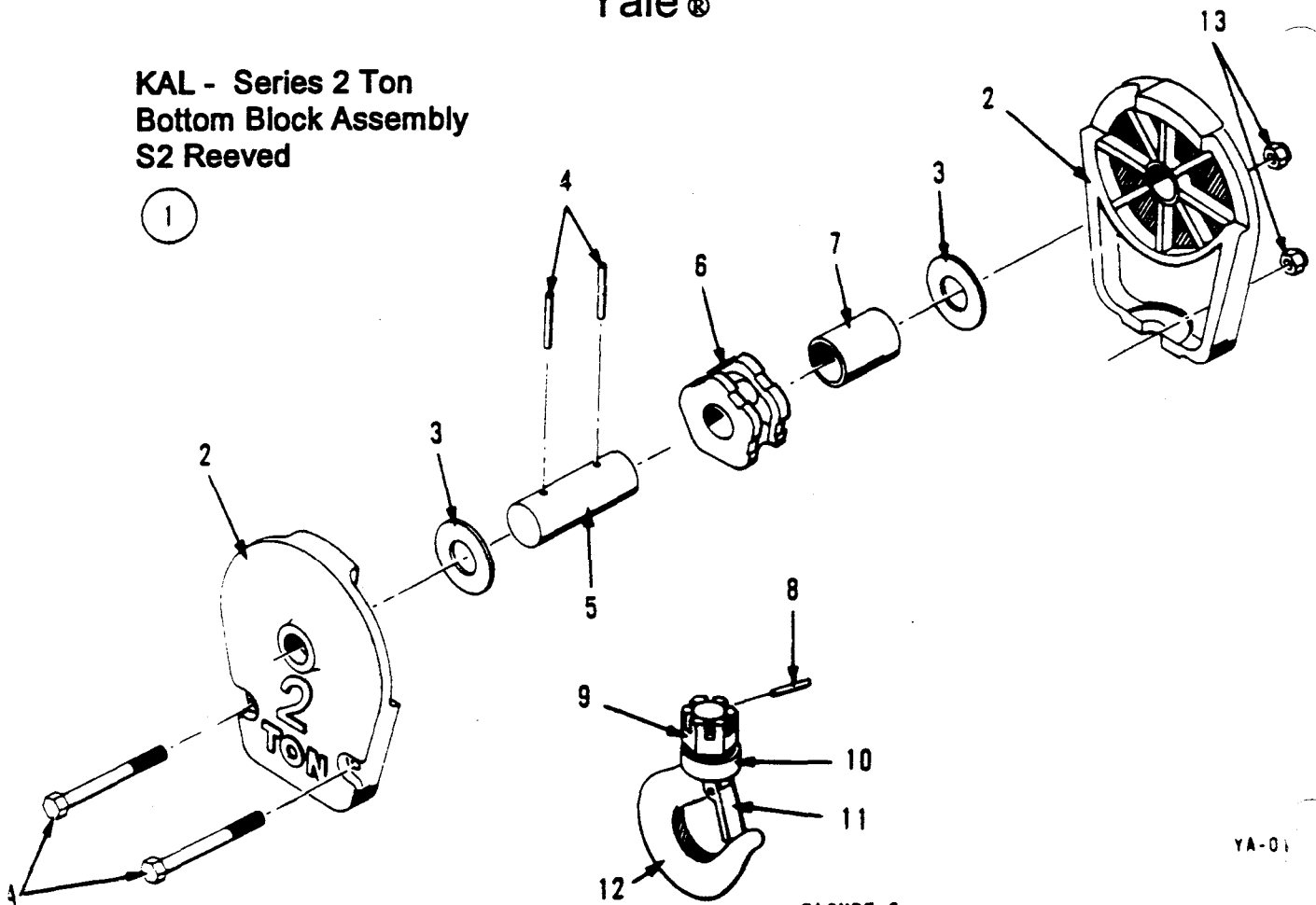

YA-01

FIGURE 8.

ITEM NUMBER	PART NUMBER	DESCRIPTION	QTY.
1	6466490-00	BOTTOM BLOCK ASSEMBLY (Inc. Items 1A through 13)	1
1A	0146724-00	HEX HEAD BOLT	2
2	6418236-00	BOTTOM BLOCK HALF	2
3	0143734-00	FLAT WASHER	2
4	0230207-00	ROLL PIN	2
5	0644897-00	SHEAVE AXLE	1
6	6473710-00	SHEAVE AND BEARING (Inc. Item 7)	1
7	6446268-00	SHEAVE BEARING	1
8	0559292-00	ROLL PIN	1
9	6443458-00	HOOK NUT	1
10	0501931-00	THRUST BEARING	1
11	0669404-00	LATCH KIT	1
12	6465840-00	HOOK (Includes Item 11)	1
13	0150153-00	LOCKNUT HEX	2

When Replacement Parts Are Needed, Order Only YALE® Factory Engineered Parts

REPAIR PARTS

Yale®

KAL- Series 3 Ton
Bottom Block Assembly
S3 Reeved

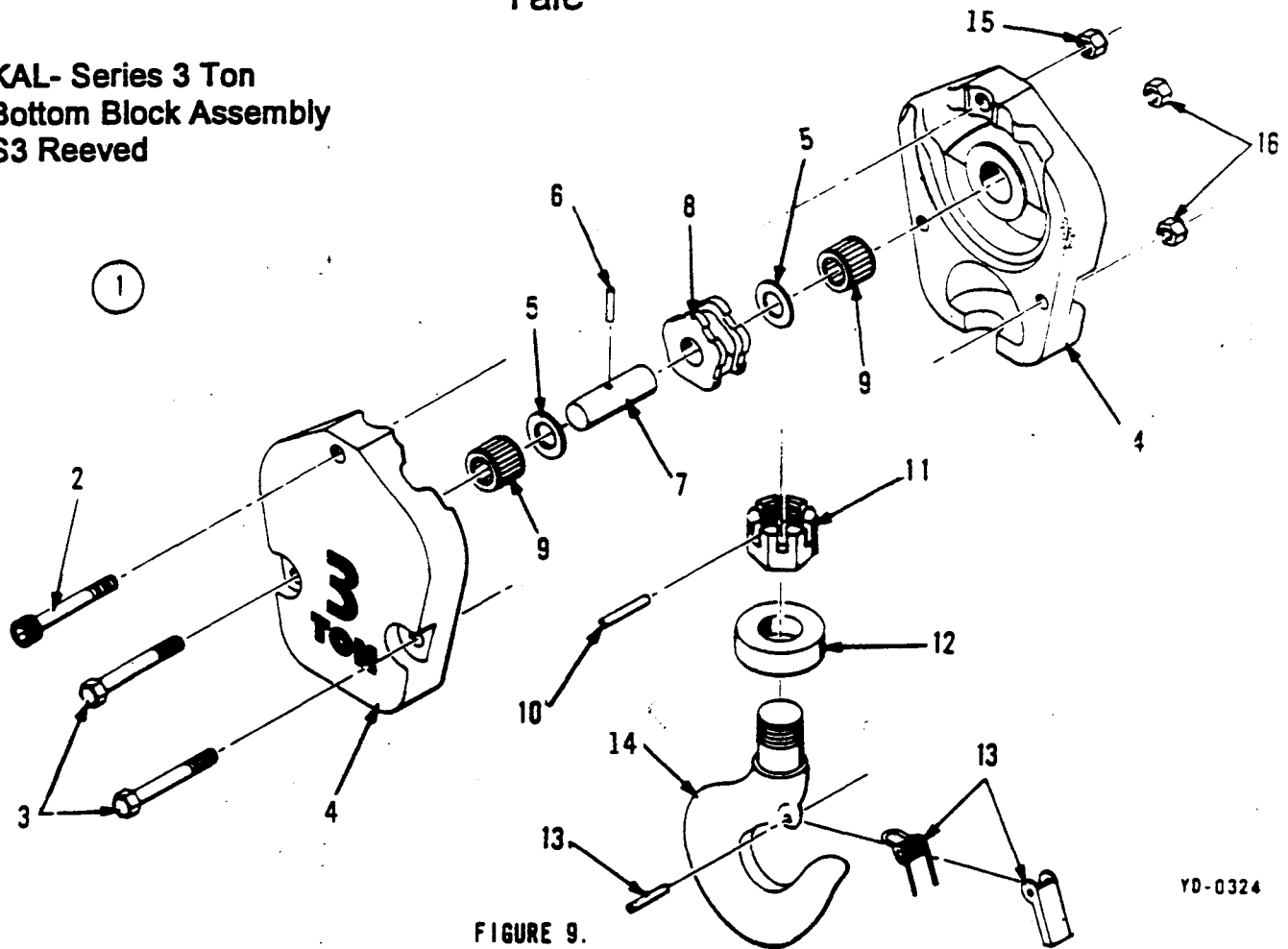

FIGURE 9.

YD-0324

ITEM NUMBER	PART NUMBER	DESCRIPTION	QTY.
1	6483610-00	BOTTOM BLOCK ASSEMBLY (Incl. Items 2 through 16)	1
2	6401549-07	SOCKET HEAD SHOULDER SCREW	1
3	0146724-00	HEX HEAD BOLT	2
4	6426436-00	BOTTOM BLOCK HALF (Inc. item 17 & 18)	2
5	6451908-00	FLAT WASHER	2
6	0329593-00	ROLL PIN	1
7	6451738-00	SHEAVE AXLE	1
8	6436733-00	SHEAVE	1
9	6451768-00	AXLE BEARING	2
10	0230212-00	ROLL PIN	1
11	6401379-04	HOOK NUT	1
12	0501932-00	THRUST BEARING	1
13	0669406-00	LATCH KIT	1
14	648360000	HOOK (Inc. Item 13)	1
15	0150152-00	LOCK NUT	1
16	0150153-00	LOCKNUT HEX	2

When Replacement Parts Are Needed, Order Only YALE® Factory Engineered Parts

REPAIR PARTS

Yale®

KAL- Series 1/2 - 1-2-3 Ton
Housing And Frame Parts

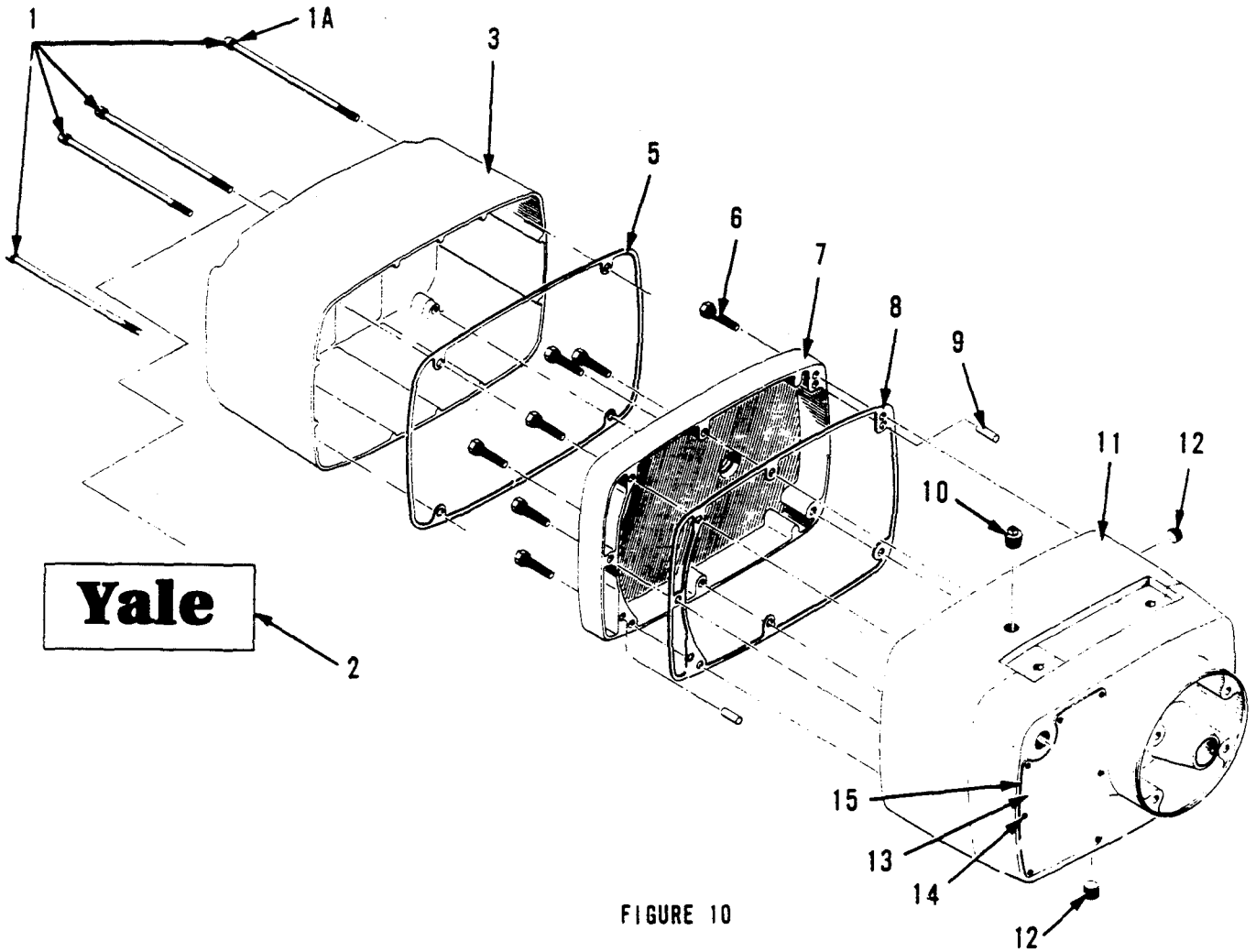

FIGURE 10

When Replacement Parts Are Needed, Order Only YALE® Factory Engineered Parts

Yale®

**KAL- Series 1/2 - 1 - 2 - 3 Ton
Housing And Frame Parts**

ITEM NUMBER	PART NUMBER	DESCRIPTION	QTY.
1	6416611-00	FILLISTER HEAD SCREW (20 to 50 in / # torque)	4
1A	6443488-00	FIBER WASHER	4
2	6444073-00	END DECAL	1
3	6403607-00	CONTROL COVER	1
5	6435574-00	CONTROL COVER GASKET	1
6	6401209-06	THREAD FORMING SCREW (115 to 125 in / # torque)	7
7	6403467-00	GEAR CASE COVER	1
8	6435554-00	GEAR CASE COVER GASKET	1
9	0116531-00	DOWEL PIN	2
10	6439518-00	BREATHER FILL PLUG	1
*11	*6405217-00	HOUSING ASSEMBLY - 1/2 TON, 1 TON	1
	*6406067-00	HOUSING ASSEMBLY - 2 TON	1
12	0230810-00	OIL LEVEL AND DRAIN PLUG	2
13	6456584-00	COVER	1
14	6401209-08	SCREW	7
15	6435564-00	COVER GASKET	1
16	6436044-00	1/2 TON CAPACITY DECAL (NOT SHOWN)	1
	6436054-00	1 TON CAPACITY DECAL (NOT SHOWN)	1
	6436064-00	2 TON CAPACITY DECAL (NOT SHOWN)	1
	6436604-00	3 TON CAPACITY DECAL (NOT SHOWN)	1
17	6444798-00	WARNING DECAL (NOT SHOWN)	1

*** DO NOT DISASSEMBLE UNDER ANY CONDITION**

When Replacement Parts Are Needed, Order Only YALE® Factory Engineered Parts

REPAIR PARTS

Yale®

KAL- Series 1/2 - 1 - 2 - 3 Ton
Gear Train And Motor Brake

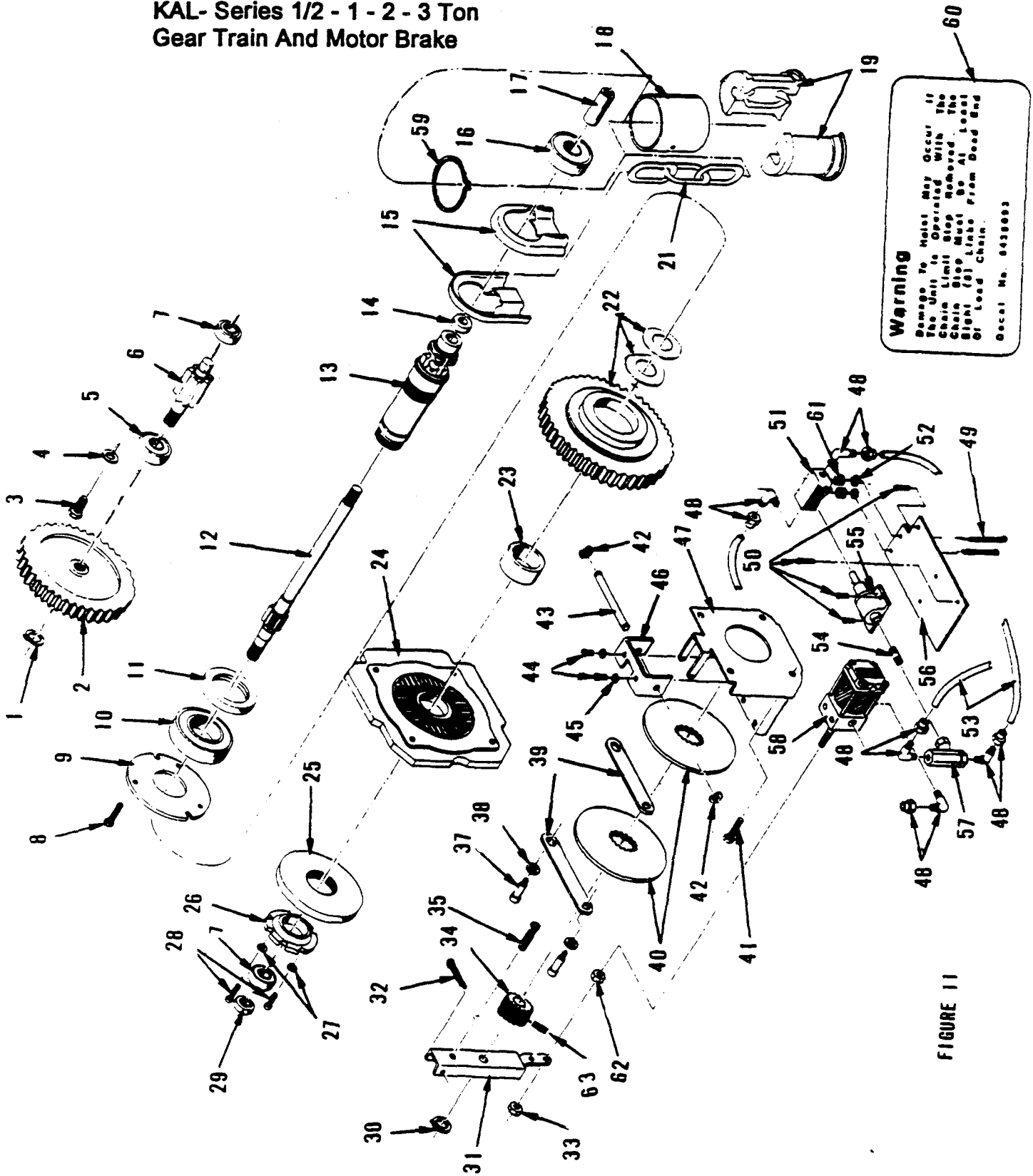

Warning
 Damage To Hoist May Occur If
 The Unit Is Operated With The
 Chain Limit Stop Removed. The
 Chain Stop Must Be At Least
 Eight (8) Links From Dead End
 Of Load Chain.
 Decal No. 6439903

FIGURE 11

When Replacement Parts Are Needed, Order Only YALE® Factory Engineered Parts

Gear Train And Motor Brake

Repair Part

ITEM	1/2 TON PART NUMBER	1 TON PART NUMBER	2 & 3 TON PART NUMBER	DESCRIPTION	QTY
1	0216767-00	0216767-00	0216767-00	RETAINING RING	1
2	6436004-00	6435124-00	6435124-00	HIGH SPEED GEAR	1
3	6401209-03	6401209-03	6401209-03	HEX HEAD SCREW	3
4	6401269-02	6401269-02	6401269-02	WASHER	3
5	0312756-00	0312756-00	0312756-00	BEARING	1
6	6435144-00	6435144-00	6435144-00	PINION	1
7	6400889-03	6400889-03	6400889-03	BEARING	2
8	6401209-05	6401209-05	6401209-05	HEX HEAD SCREW	3
9	6433783-00	6433783-00	6433783-00	SPACER PLATE	1
10	0151197-00	0151197-00	0151197-00	BEARING	1
11	6401229-01	6401229-01	6401229-01	SEAL	1
12	6456504-00	6456524-00	6456524-00	DRIVING PINION	1
13	6440244-00	6440244-00	6440244-00	LOAD SHEAVE	1
14	6443998-00	6443998-00	6443998-00	SEAL	1
15	6438154-00	6438154-00	6438154-00	CHAIN GUIDE AND STRIPPER HALF	2
16	0151208-00	0151208-00	0151208-00	BEARING	1
17	6428333-00	6428333-00	6428333-00	COUPLING	1
18	6435803-00	6435803-00	6435803-00	CHAIN STOP SLEEVE	1
19	6446544-00	6446544-00	6446544-00	CHAIN STOP HALF	2
21	SEE TABLE	SEE TABLE	SEE TABLE	LOAD CHAIN	1
22	6442584-02	6442584-03	6442584-07	OVER LOAD CLUTCH	1
23	6416351-00	6416351-00	6416351-00	BUSHING	1
24	6438664-00	6438664-00	6438664-00	LOAD BRAKE ASSEMBLY	1
25	6444664-00	6444664-00	6444664-00	FRICTION PLATE	1
26	6435913-00	6435913-00	6435913-00	JAM NUT	1
27	0150318-00	0150318-00	0150318-00	LOCKWASHER	2
28	0656253-00	0656253-00	0656253-00	SCREW	2
29	6401219-01	6401219-01	6401219-01	SEAL	1
30	6401409-02	6401409-02	6401409-02	RETAINING RING	1
31	6423961-01	6423961-01	6423961-01	CHANNEL ASSEMBLY	1
32	6401999-01	6401999-01	6401999-01	PIN	1
33	6470394-00	6470394-00	6470394-00	LOCKNUT - Nylon	1
34	6488573-00	6488573-00	6488573-00	DRIVE BLOCK	1
35	6401279-01	6401279-01	6401279-01	SOCKET SCREW	1
36	6439608-00	6439608-00	6439608-00	CLINCH NUT	1
37	6416551-00	6416551-00	6416551-00	SHOULDER SCREW	2
38	0150359-00	0150359-00	0150359-00	LOCKWASHER	2
39	6416481-00	6416481-00	6416481-00	PLATE	2
40	6488583-00	6488583-00	6488583-00	BRAKE DISC	2
41	6401209-09	6401209-09	6401209-09	SCREWS	2
42	0159143-00	0159143-00	0159143-00	RETAINERS	2
43	6429463-00	6429463-00	6429463-00	PIN	1
44	6401209-07	6401209-07	6401209-07	SCREWS	2
45	0656193-00	0656193-00	0656193-00	LOCKWASHERS	2
46	6429453-00	6429453-00	6429453-00	BRACKET	1
47	6417316-00	6417316-00	6417316-00	BRACKET	1
48	5041148-00	5041148-00	5041148-00	ELBOWS	5
49	6401209-04	6401209-04	6401209-04	SCREWS	2
50	6401209-02	6401209-02	6401209-02	SCREWS	4
51	6410008-00	6410008-00	6410008-00	THREE WAY VALVE	1
52	0161032-00	0161032-00	0161032-00	WASHERS	2
53	5041178-81	5041178-81	5041178-81	PLASTIC TUBING (SPECIFY LENGTH)	-
54	6439213-00	6439213-00	6439213-00	NIPPLE	1
55	6409988-02	6409988-02	6409988-02	CONTROL CYLINDER	1
56	6430703-00	6430703-00	6430703-00	MOUNTING PLATE	1
57	5019228-00	5019228-00	5019228-00	FLOW CONTROL VALVE	1
58	6451483-02	6451483-02	6451483-02	AIR CYLINDER	1
59	6401889-01	6401889-01	6401889-01	RETAINING RING	1
60	6439093-00	6439093-00	6439093-00	DECAL	1
61	6401901-00	6401901-00	6401901-00	SPACER	2
62	0149727-00	0149727-00	0149727-00	JAM NUT	1
63	0561668-00	0561668-00	0561668-00	SET SCREW	1

INCLUDES ITEM 23

PLATED LOAD CHAIN TABLE

Item No.	Lift	1/2 & 1 Ton	2 Ton	3 Ton
21	10 ft.	6456662-10	6456672-10	6470422-10
21	12 ft.	6456662-12	6456672-12	6470422-12
21	15 ft.	6456662-15	6456672-15	6470422-15
21	20 ft.	6456662-20	6456672-20	6470422-20

NOTE: NON-STANDARD LIFTS - ORDER 6427004-24 X LENGTH REQUIRED IN FEET

REPAIR PARTS

Yale®

KAL Series Air Motor, Connections And Pendant

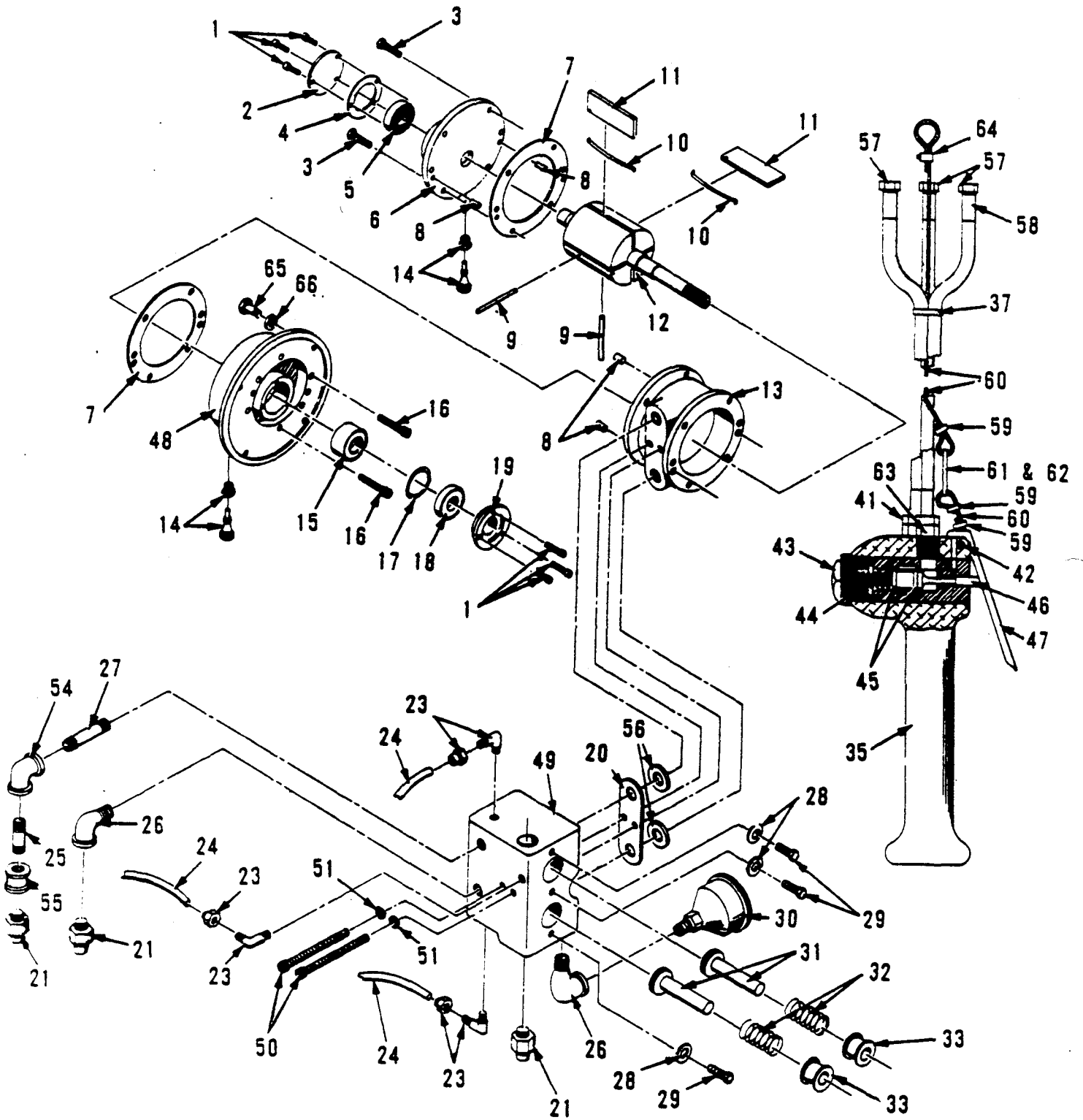

FIGURE 12

When Replacement Parts Are Needed, Order Only YALE® Factory Engineered Parts

Yale®

KAL Series Air Motor, Connections And Pendant

ITEM NO.	PART NUMBER	DESCRIPTION	QTY.
	6437294-01	MOTOR ASSEMBLY	1
1	6453748-00	SCREW	6
2	6421178-00	END CAP	1
3	6453758-00	SCREW	6
4	6421188-00	GASKET	1
5	6421088-00	BEARING	1
6	6421028-00	END PLATE	1
7	6421138-00	GASKET	2
8	6421128-00	DOWEL PIN	4
9	6421068-00	PUSH PIN	2
10	6421058-00	VANE SPRING	4
11	6421048-00	VANE	4
12	6453728-00	ROTOR ASSEMBLY	1
13	6421008-00	BODY	1
14	6453768-00	OILER ASSEMBLY	2
15	6421078-00	BEARING	1
16	6453778-00	SCREW	6
17	6421198-00	"O" RING	1
18	6421118-00	SEAL	1
19	6421168-00	END CAP	1
20	6440903-00	GASKET	1
21	6463208-00	MALE ADAPTER	3
22			
23	5041148-00	MALE ELBOW	3
24	5041178-81	PLASTIC TUBE	*
25	0103824-00	NIPPLE (LENGTH 2")	1
26	0157583-00	PIPE ELB OW	2
27	0103825-00	NIPPLE (LENGTH 2 1/2")	1
28	6401269-02	WASHER	6
29	6400869-03	SCREW (TFS)	3
30	6418048-02	MUFFLER	1
31	6445563-00	PISTON ASSEMBLY	2
32	0110589-00	SPRING	2
33	6445553-00	PISTON RETAINER ASSEMBLY	2
35	6447384-00	PENDANT HANDLE	1
36	6457368-04	HOSE, AIR	**
37	6455938-00	TY WRAPS	***
38			
39			
40			
41	6463198-00	MALE ADAPTER	1****
42	6447384-01	THROTTLE LEVER PIN	1
43	6447384-06	VALVE CAP	2
44	6447384-05	VALVE SPRING	2
45	6447384-04	VALVE SEAL RING	4
46	6447384-03	VALVE ASSEMBLY	2
47	6447384-02	THROTTLE LEVER	2
48	6453738-00	END PLATE	1
49	6431676-00	MANIFOLD	1
50	0655739-00	SOCKET HEAD SCREW	2
51	0150308-00	WASHER	2
54	5018709-02	90 DEGREE FEMALE ELBOW	1
55	0103852-00	COUPLING	1
56	6443643-00	LOCATING SPACER	2
57	6463218-00	HOSE INSERTS	6
58	6463228-00	HOSE FERRULES	6
59	6455928-00	SWAGE FITTING	3
60	6464988-00	CABLE	***
61	6442303-00	DECAL MOUNTING PLATE	1
62	6438123-00	DECAL	2
63	6444263-00	RESTRICTER BUSHING	2*****
64	6455918-00	CLAMP	1
65	5004059-01	HEX SCREW	4
66	0150256-00	LOCKWASHER	4

REPAIR PARTS

Yale®

KAL - Series 1/2 - 1 - 2 - 3 Ton
Suspension Parts

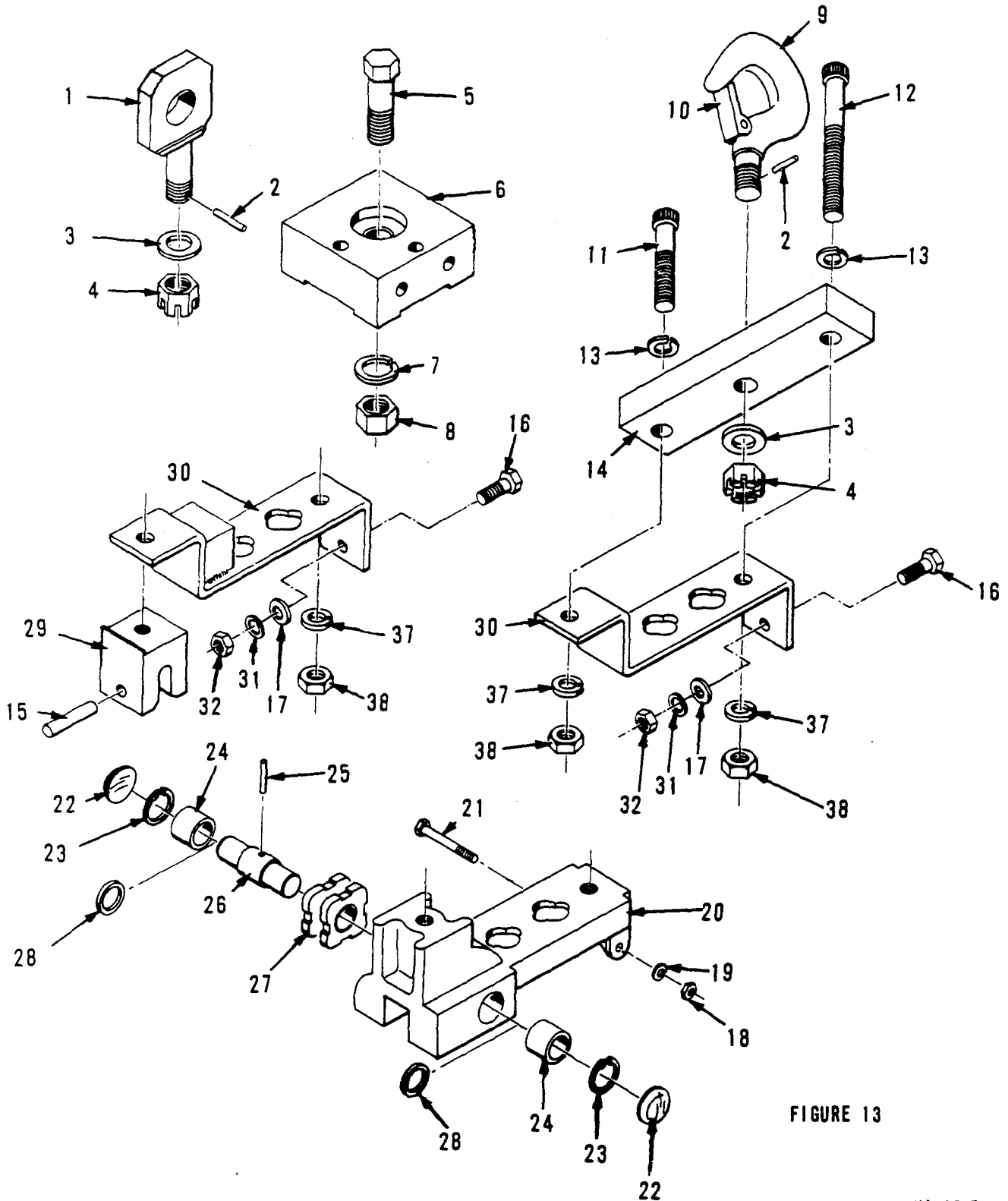

FIGURE 13

YA-0305

When Replacement Parts Are Needed, Order Only YALE® Factory Engineered Parts

KAL SERIES

Yale®

**KAL- Series 1/2 - 1- 2-3 Ton
Suspension Parts**

ITEM NUMBER	PART NUMBER 1/2 TON & 1	PART NUMBER 2 TON	PART NUMBER 3 TON	DESCRIPTION	QTY.
1	*	6431333-03	6445774-00	Clevis	1
2	0559292-00	0559292-00	0230212-00	Roll Pin	1
3	0544158-00	0544158-00	0573873-00	Thrust Washer	1
4	6443458-00	644358-00	6401379-04	Slotted Nut	1
5	2030916-00	2030916-00	6436913-00	Hex Head Bolt	1
	150/160 ft. lbs.	150/160 ft. lbs.	190/200 ft. lbs.		
6	6436444-00	6436444-00	6445764-00	Trolley Adapter	1
7	2031397-00	2031397-00	0150298-00	Lockwasher	1
8	5020979-04	5020979-04	0213616-00	Hex Nut	1
9	6465830-00	6455840-00	6483620-00	Top Hook W/Latch	1
10	0669402-00	0669404-00	0669406-00	Latch Kit	
11	0655900-00	0655900-00	0655971-00	Socket Head Screw (40 to 50 Ft/Lbs. Torque)	1
12	6401299-01	6401299-01	0655976-00	Socket Head Screw (40 to 50 Ft/Lbs. Torque)	1
13	0150326-00	0150326-00	0114146-00	Lockwasher.	2
14	6435384-00	6435974-00	6445744-00	Top Crosshead	1
15		6429353-00		Anchor Pin	1
16	0623067-00	0623067-00		Hex Head Bolt	1
17	0161037-00	0161037-00		Washer	1
18			5004429-01	Hex Nut	1
19			0150290-00	Lockwasher	1
20			6426426-00	Bottom Crosshead	1
21			0655803-00	Hex Bolt	1
22			6451748-00	Expansion Cap	2
23			5019089-01	Retaining Ring	2
24			6451768-00	Roller Bearing	2
25			0329593-00	Roll Pin	1
26			6451738-00	Pocket Wheel Axle	1
27			6451728-00	Pocket Wheel	1
28			6451908-00	Washer	2
29		6435793-00		Anchor	1
30	6438874-00	6444494-00		Bottom Crosshead	1
31	0150262-00	0150262-00		Lockwasher	1
32	0149366-00	0149366-00		Hex Nut	1
33					
34			6491450-00	Bearing & Cap Assm. (Inc. Items 22,23, 24, & 28)	1
35			6491460-00	Pocket Wheel & Pin Assm. (Inc. Items 25, 26, 27 & 34)	1
36			6491090-00	Crosshead Kit (Inc. Items 18 thru 28)	1
37	0621533-00	0621533-00		Lockwasher	2**
38	5023829-02	5023829-02		1/2-13 Hex Nut (40 to 50 Ft/Lbs Torque)	2**

* One half ton P/N 6431333-01, one ton P/N 6431333-02. ** One (1) each On Two ton.

REPAIR PARTS



KAL Series Plain Trolley Assembly

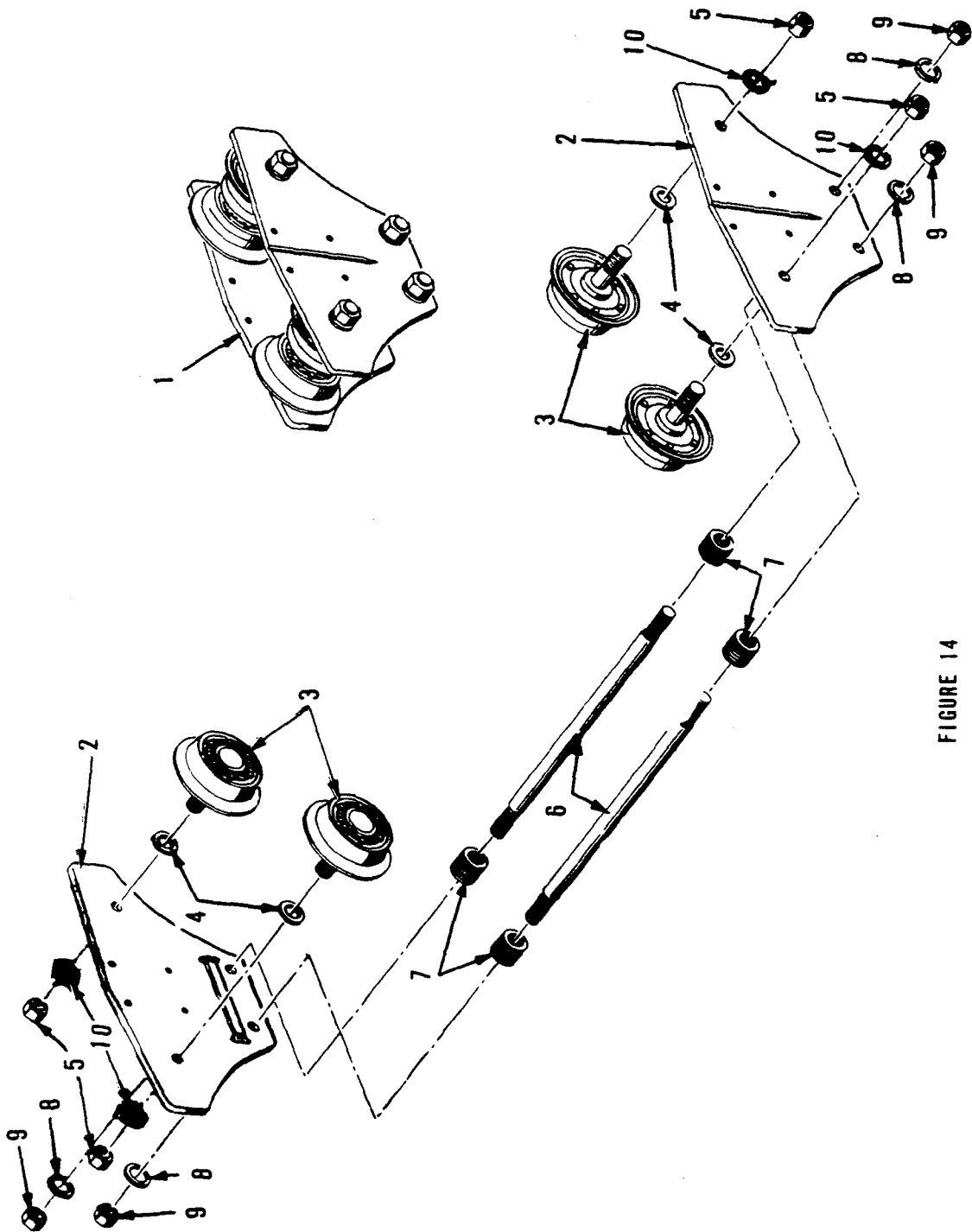

FIGURE 14

YA-0306

When Replacement Parts Are Needed, Order Only YALE® Factory Engineered Parts

KAL SERIES

Yale®

**KAL Series 1/2 And 1 Ton
Plain Trolley Assembly With Pressed Steel Wheels
For 5 To 12 Inch Standard I-Beam**

ITEM NUMBER	PART NUMBER	DESCRIPTION	QTY.
1	6477960-00	Trolley Assembly (consists of items 2 through 10)	1
2	0112320-00	Trolley Side Plate	2
3	0249628-00	Track Wheel	4
4	0236018-00	Spacer	4
5	0149375-00	Hex Nut	4
6	0101024-00	Double End Stud	2
*7	0114200-00	Adjusting Washers	28
8	0150268-00	Lockwashers	4
9	0149374-00	Hex Nut	4
10	0150270-00	Lockwashers	4

**KAL Series 2 Ton
Plain Trolley Assembly With Pressed Steel Wheels
For 6 To 18 Inch Standard I-Beams**

ITEM NUMBER	PART NUMBER	DESCRIPTION	QTY.
1	6477970-00	Trolley Assembly (consists of items 2 through 10)	1
2	0595378-00	Trolley Side Plate	2
3	0501071-00	Track Wheel	4
4	5006361-00	Spacer	8
5	0149376-00	Hex Nut	4
6	0101020-00	Double End Stud	2
*7	0114200-00	Adjusting Washers	48
8	0150268-00	Lockwashers	4
9	0149374-00	Hex Nut	4
10	0150296-00	Lockwashers	4

* FOR SPACING OF ADJUSTING WASHERS SEE PAGE 8.

When Replacement Parts Are Needed, Order Only YALE® Factory Engineered Parts

REPAIR PARTS



KAL Series 3 Ton Plain Trolley Assembly For 6 To 24 Inch Standard I-Beam

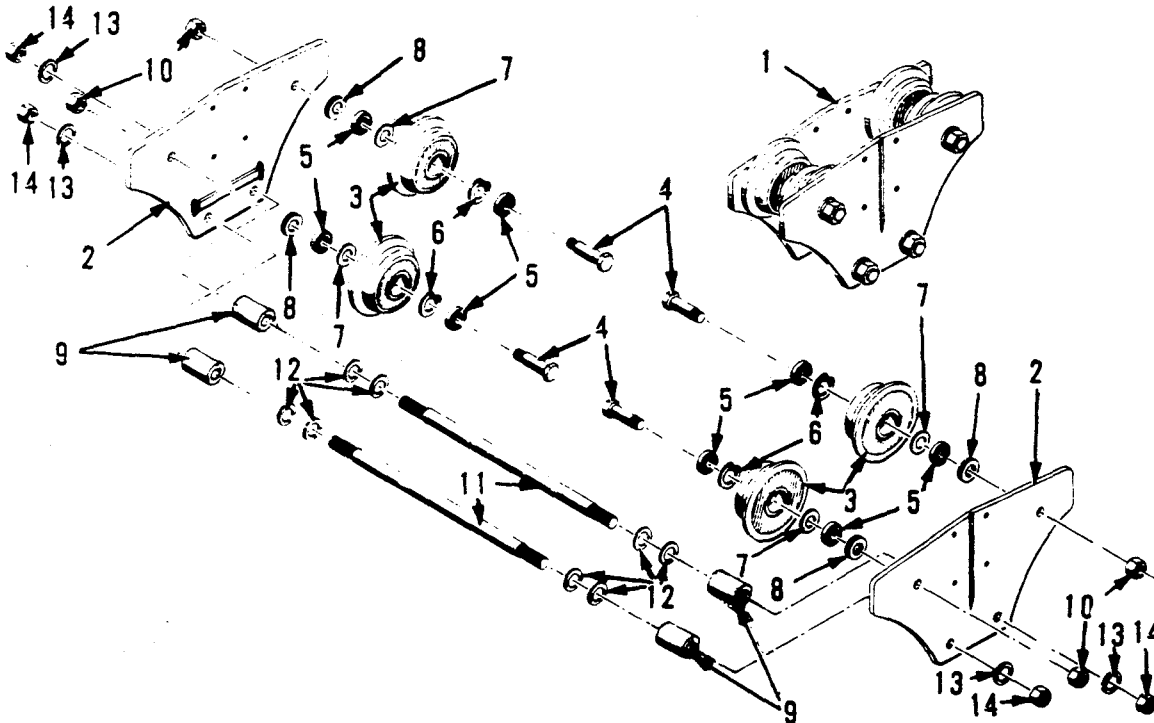

FIGURE 15

ITEM NUMBER	PART NUMBER	DESCRIPTION	QTY
1	6490870-00	PLAIN TROLLEY ASSEMBLY (Includes Items 2 Through 14)	1
2	0664025-00	SIDE PLATE	2
3	6412133-00	WHEEL	4
4	0664038-00	WHEEL AXLE	4
5	0664037-00	BEARING ASSEMBLY	8
6	0664040-00	BEARING SPACER	4
7	5024531-00	BEARING SHIM	4
8	0664039-00	SPACER	4
9	0629893-00	SPACER	4
10	0213606-00	STOVER NUT	4
11	0101055-00	STUD	2
*12	0114197-00	ADJUSTING WASHER	24
13	0150297-00	LOCKWASHER	4
14	0149716-00	HEX NUT	4

* FOR SPACING OF ADJUSTING WASHERS SEE PAGE 8

When Replacement Parts Are Needed, Order Only YALE[®] Factory Engineered Parts



KAL Series FOR 4 INCH I-BEAMS
Special Trolley Assembly

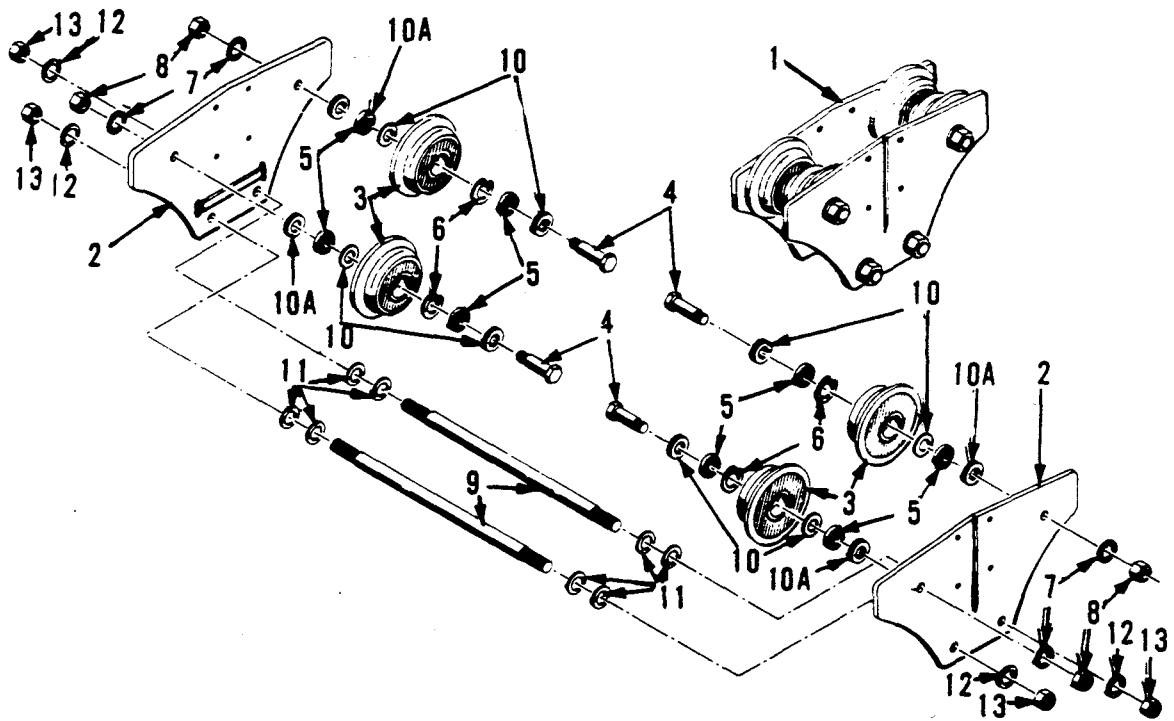

FIGURE 23

ITEM NUMBER	1/2 TON PART NUMBER	1 AND 2 TON PART NUMBER	DESCRIPTION	QTY
1	6477980-00	6478040-00	TROLLEY ASSEMBLY (consists of items 2 through 13)	1
2	0112381-00	5035954-00	TROLLEY SIDE PLATES	2
3	0112725-00	5029871-00	TRACK WHEELS	4
4	0112382-00	5029881-00	WHEEL AXLE	4
5	0100861-00	0250647-00	BEARING	8
6	0645705-00	6400469-04	SNAP RING	4
7	0150370-00		SHAKEPROOF WASHER	4
8	0149713-00	0150157-00	AXLE NUT	4
9	0101018-00	0101015-00	DOUBLE END STUDS	2
10	6459738-00		SPACER	20
10A		0161109-00	SPACER	4
11	0114200-00		ADJUSTING WASHER	8
		0114200-00	ADJUSTING WASHER	12
12	0150268-00	0150370-00	LOCKWASHER	4
13	0149374-00	0149374-00	HEX NUT	4

When Replacement Parts Are Needed, Order Only YALE[®] Factory Engineered Parts

REPAIR PARTS



KAL Series, Trolley Assembly

1/2, 1 AND 2 TON PATENTED TRACK-LOAD BAR

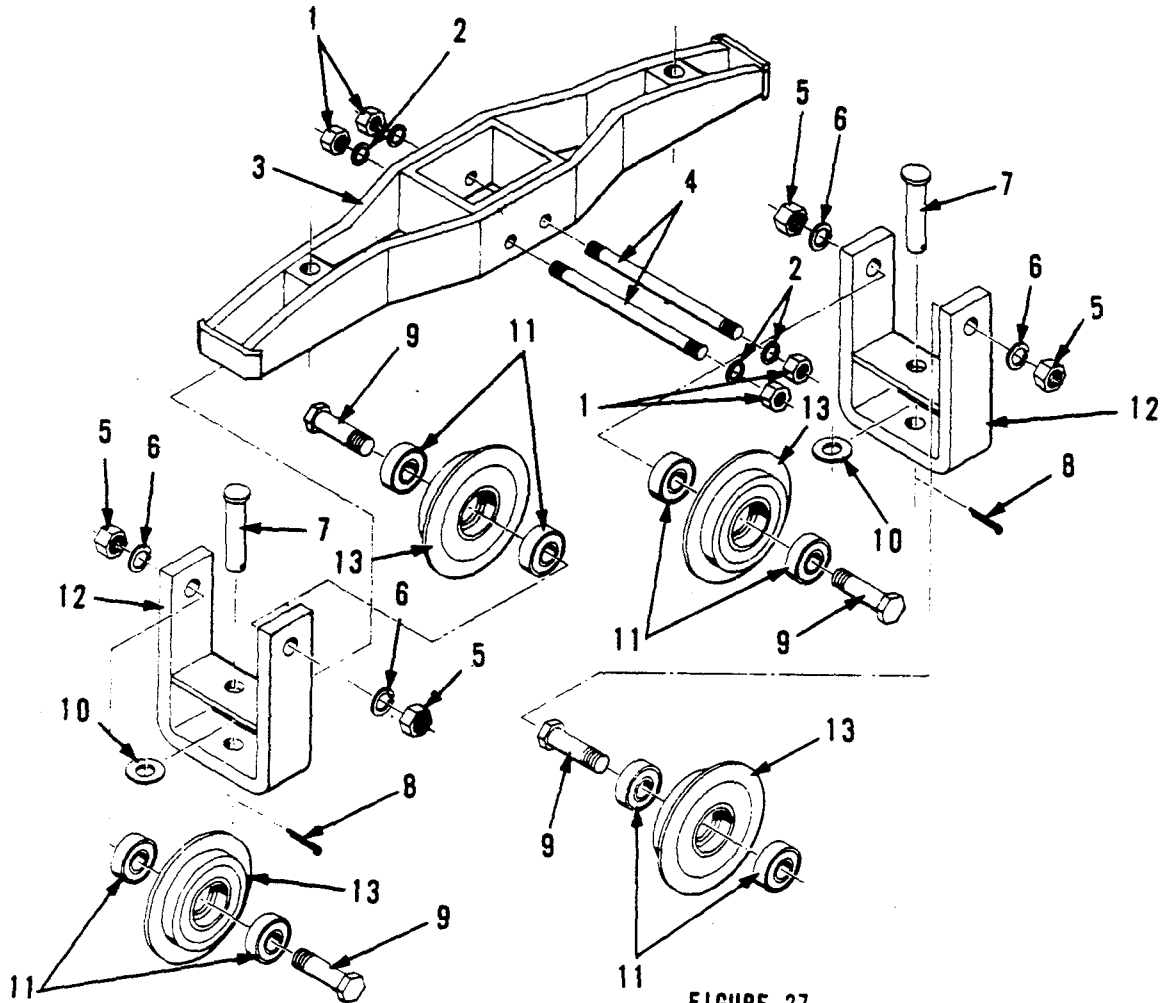

FIGURE 27

YE-0351

ITEM NUMBER	2 IN. PAT. TRACK PART NUMBER	3 1/4 IN. PAT. TRACK NUMBER	DESCRIPTION	QTY
*	6490890-00	6490920-00	TROLLEY ASSEMBLY	1
1	0149374-00	0149374-00	HEX NUT	4
2	0150371-00	0150371-00	LOCKWASHER	4
3	0117144-00	0117144-00	LOAD BAR	1
4	0101018-00	0101018-00	DOUBLE END STUD	2
5	0149714-00	0149714-00	JAM NUT	4
6	0150268-00	0150268-00	LOCKWASHER	4
7	0107065-00	0107065-00	PIN	2
8	0102812-00	0102812-00	COTTER PIN	2
9 **	0112321-00	0112321-00	SHAFT	4
10	0114188-00	0114188-00	WASHER	2
11	0100854-00	0100854-00	BEARING	8
12	0112507-00	0112426-00	YOKE	2
13	0112738-00	0112727-00	TROLLEY WHEEL	4

* 6493350-00 (2 Ton Trolley Assembly)

** 0112519-00 (2 Ton Axle Shaft)

When Replacement Parts Are Needed, Order Only YALE® Factory Engineered Parts

KAL SERIES



KAL Series Plain Trolley Assembly

FOR PATENTED TRACK - 2, 3 1/4 & 4 1/16 INCH FLANGE - 5/8 INCH MAX. THICKNESS

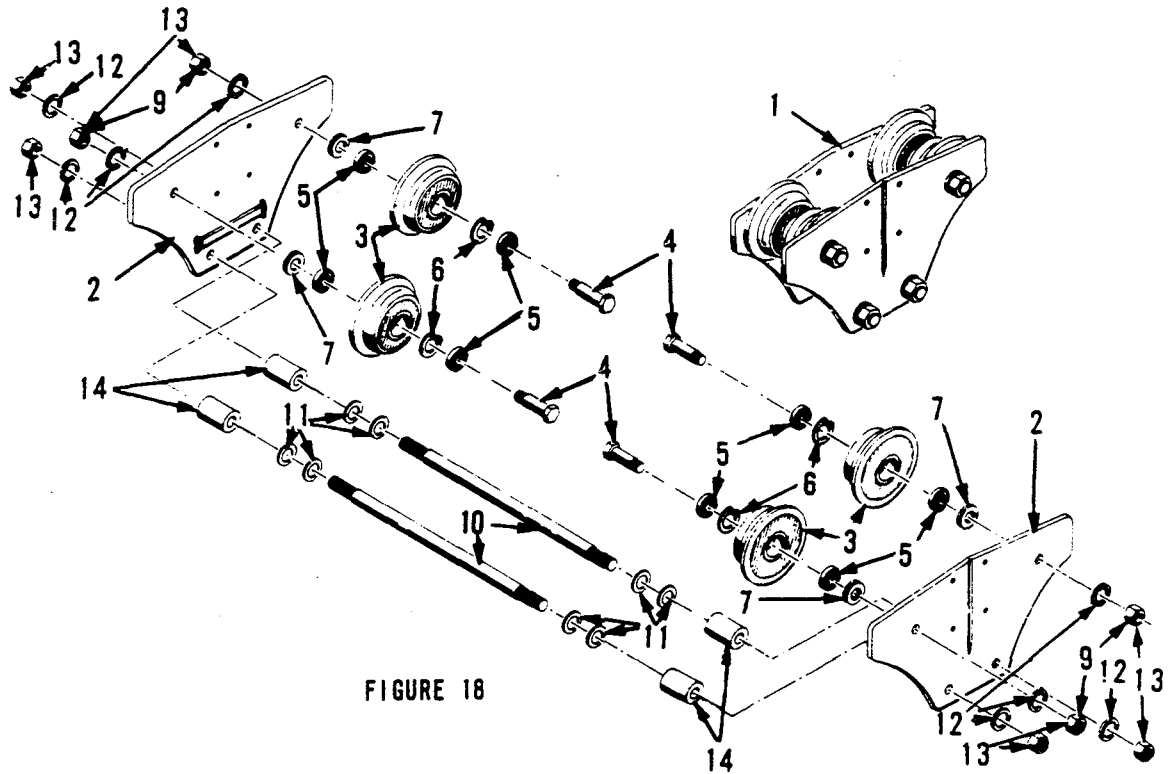

FIGURE 18

ITEM NUMBER	1/2 AND 1 TON 2 INCH TRACK	2 TON 2 INCH TRACK	1/2 AND 2 TON 3 1/4 INCH TRACK	3 TON 3 1/4 & 4 1/16 INCH THICK	DESCRIPTION	QTY
1	6490900-00	6490910-00	6478000-00	5024080-00	TROLLEY ASSEMBLY	1
2	0112320-00	0112320-00	0112320-00	0664025-00	SIDEPLATE	2
3	0112738-00	0112738-00	5000473-00	5018433-00	WHEEL	4
4	0112321-00	0112519-00	0624646-00	5024561-00	WHEEL AXLE	4
5	0100854-00	0100854-00	0250645-00	0664037-00	BEARING	8
6			6400469-02	0604040-00	SNAP RING OR SPACER	4
7			0114221-00	0665193-00	SPACER WASHER (Between Wheel & Sideplate)	4
8	0150371-00	0150371-00			LOCKWASHER F/WHEEL	4
9	0149714-00	0149714-00	0150160-00		LOCKNUT	4
10	0101018-00	0101024-00	0101017-00	0101053-00	DOUBLE END STUD	2
11		0114200-00	0114200-00	0114197-00	ADJUSTING WASHER	**
12	0214111-00	0214111-00	0214111-00	0150297-00	LOCKWASHER (D.E. Stud)	4*
13	0149374-00	0149374-00	0149374-00	0149716-00	HEX NUT	4*
14				5000239-00	SPACER FOR END STUD	4

* 8 Required On 3 Ton.
** As Required.

When Replacement Parts Are Needed, Order Only YALE® Factory Engineered Parts

REPAIR PARTS



KAL Series, Geared Trolley Assembly

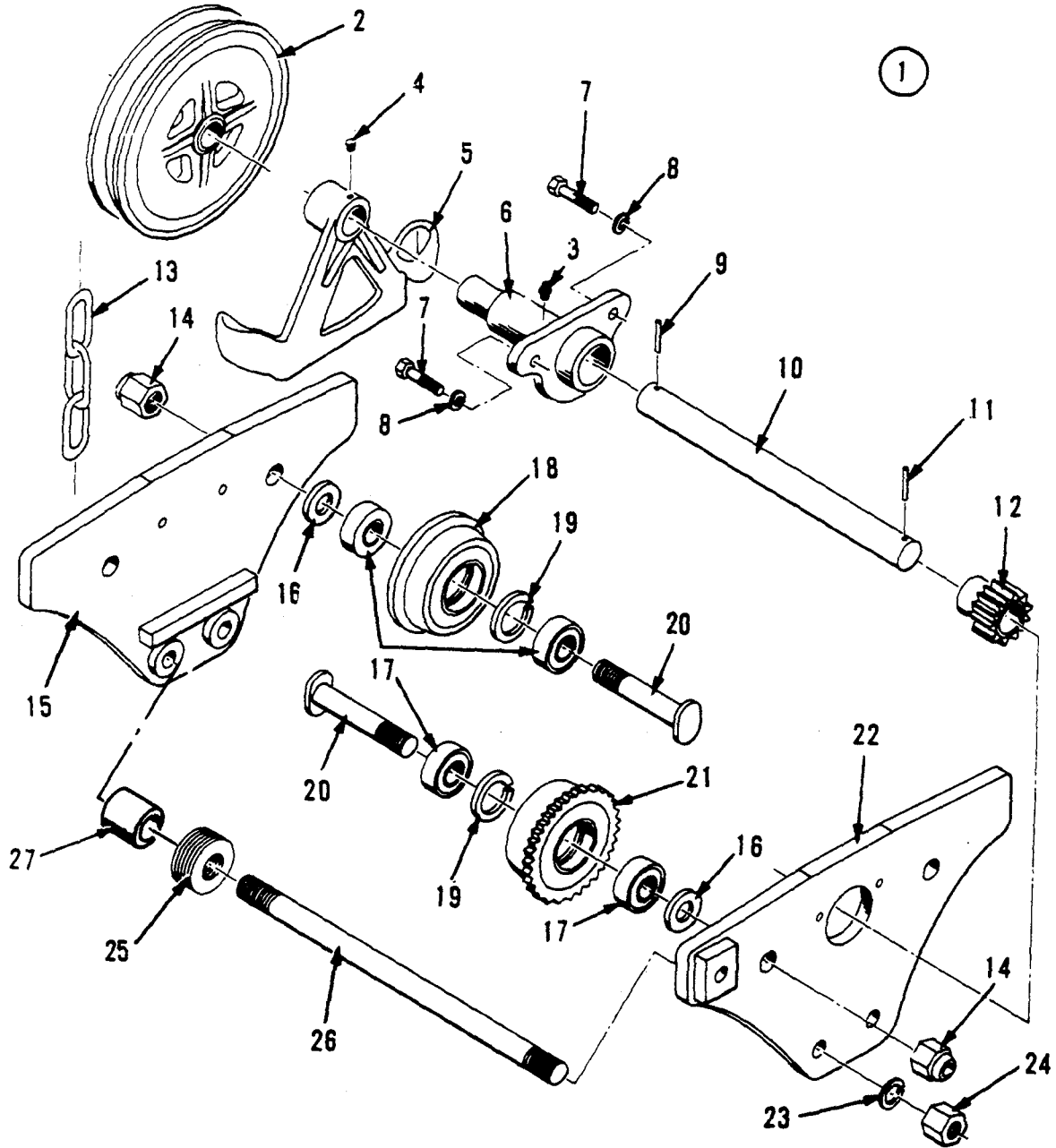

FIGURE 18.

YA-0308

When Replacement Parts Are Needed, Order Only YALE® Factory Engineered Parts

KAL SERIES

Yale®

KAL Series Geared Trolley Assembly

ITEM NUMBER	5-12 Inch Beam	6-12 Inch Beam	6-24 Inch Beam	DESCRIPTION	QTY.
	1/2 & 1 TON PART NUMBER	2 TON PART NUMBER	3 TON PART NUMBER		
1	6446530-00	6490860-00	6490880-00	Geared Trolley Assm	1
2	0250218-00	0250218-00	0250218-00	Handwheel	1
3	0227845-00	0227845-00	0227845-00	Alemite Fitting	1
4	0156287-00	0156287-00	0156287-00	Alemite Fitting	1
5	0603328-00	0603328-00	0603328-00	Chain Guide	1
6	0603329-00	0603329-00	0646611-00	Extension Bracket	1
7	0570482-00	0570482-00	0570482-00	Hex Head Screw	2
8	0150264-00	0150264-00	0150264-00	Lockwasher	2
9	0230207-00	0230207-00	0230207-00	Roll Pin	1
10	0603336-00	0603336-00	0646612-00	Shaft	1
11	0250666-00	0250666-00	0250666-00	Drive-Lok Pin	1
12	0250202-00	0250202-00	0250202-00	Pinion	1
13	0033730-00	0033730-00	0033730-00	Hand Chain Spec. Length	1
14	0150160-00	0150157-00	0213606-00	Stover Nut	4
15	5021844-00	0625391-00	0664025-00	Trolley Side Plate, Plain	1
16	5006371-00		0664039-00	Spacer	4
17	0250645-00	0250647-00	0664037-00	Bearing	8
18	0249664-00	6412103-00	6412133-00	Trolley Wheel, Plain	2
19	6400469-02	6400469-04	*	Retaining Ring	4
20	5024441-00	0250576-00	0664038-00	Axle	4
21	0249666-00	6412113-00	6412143-00	Trolley Wheel, Geared	2
22	5021854-00	0625392-00	0664027-00	Trolley Side Plate, Geared	1
23	0150268-00	0150268-00	0150297-00	Lockwasher	4
24	0149713-00	0149374-00	0149716-00	Hex Nut	4
25	0114200-00	0114200-00	0114197-00	Adjusting Washers	**
26	0101016-00	0101020-00	0101055-00	Double End Stud	2
27			0629893-00	Spacer	4
28			5024531-00	Bearing Shim	4

* 3 Ton Unit Uses A Spacer Between The Wheel Bearings Part Number 0664040-00, 4 Required.
0664040-00, 4 Required.

** As Required.

When Replacement Parts Are Needed, Order Only YALE® Factory Engineered Parts

Yale® Hoists

RT SERIES 1/2 THROUGH 2 TON TROLLEY ASSEMBLY

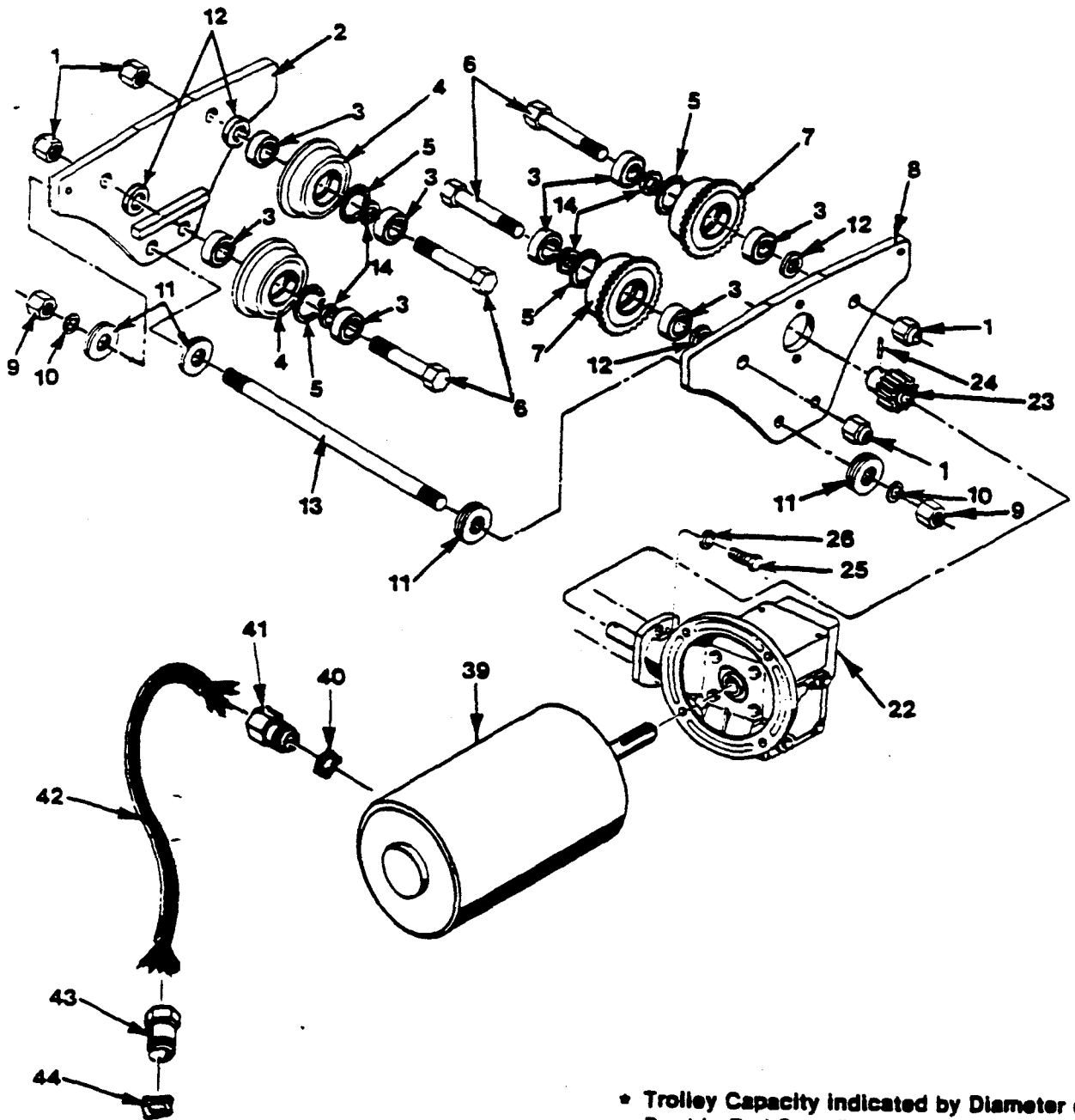

• Trolley Capacity Indicated by Diameter of Double End Stud (Item 13).

When Replacement Parts Are Needed, Order Only Yale® Factory Engineered Parts

REVISED JAN. 1992

51.1

KEL SERIES

Yale® Hoists

RT 1/2 THROUGH 2 TON (6-15 inch I-beam) TROLLEY ASSEMBLY

ITEM NUMBER	AMERICAN STANDARD 6-15" I-BEAM	PATENTED TRACK	DESCRIPTION	QTY
	6465932-00	6467752-00	Trolley assembly (includes items 1-14)	1
1	0150158-00	0150158-00	Nut	4
2	6481634-00	6481634-00	Sideplate, plain	1
3	5003539-07	5003539-07	Bearing	8
4	6412103-00	0650863-00	Wheel, plain	2
5	6400469-04	6400469-04	Retaining ring	4
6	0650864-00	0650864-00	Axle, wheel	4
7	6412113-00	5011583-00	Wheel, geared	2
8	6481644-00	6481634-00	Sideplate, geared	1
9	0149374-00	0149374-00	Hex nut	4
10	0150268-00	0150268-00	Lockwasher	4
11	0114200-00	0114200-00	Adjustment washer	48/20
12	6445021-05	0114207-00	Washer	4
13	0101020-00	0101024-00	Double end stud (5/8 in.)	2
14	0161158-00	0161158-00	Washer	16/24
22	SEE TABLE	SEE TABLE	Gearcase	1
	6467002-00		Rt mounting kit (includes items 23-26)	
23	6462883-00	6462883-00	Pinion	1
24	6462973-01	6462973-01	Groove pin	1
25	0554856-00	0554856-00	Bolt	2
26	0150266-00	0150266-00	Lockwasher	2
39	*	*	Motor Assembly	1
40	0103739-00	0103739-00	Lock nut	1
41	6401569-10	6401569-10	Water tight connector	1
42	6431261-81	6431261-81	Power cord	7 ft
43	6401569-18	6401569-18	Water tight connector	1
44	0103740-00	0103740-00	Locknut	1

* When ordering motors give complete data on motor nameplate.

GEAR TABLE

TRAVEL SPEED (FT/MIN)	GEARCASE	RATIO
15	6462923-30	30:1
30	6462923-15	15:1
45	6462923-10	10:1
90	6462923-05	5:1

WHEN REPLACEMENT PARTS ARE NEEDED, ORDER ONLY YALE® FACTORY ENGINEERED PARTS

KEL SERIES

51-2

REVISED MARCH 1996

Yale Hoisting Equipment

REPAIR PARTS

MOTORIZED TROLLEY DRIVE (RT)

TROLLEY GEAR BOX
133 and 175 SERIES

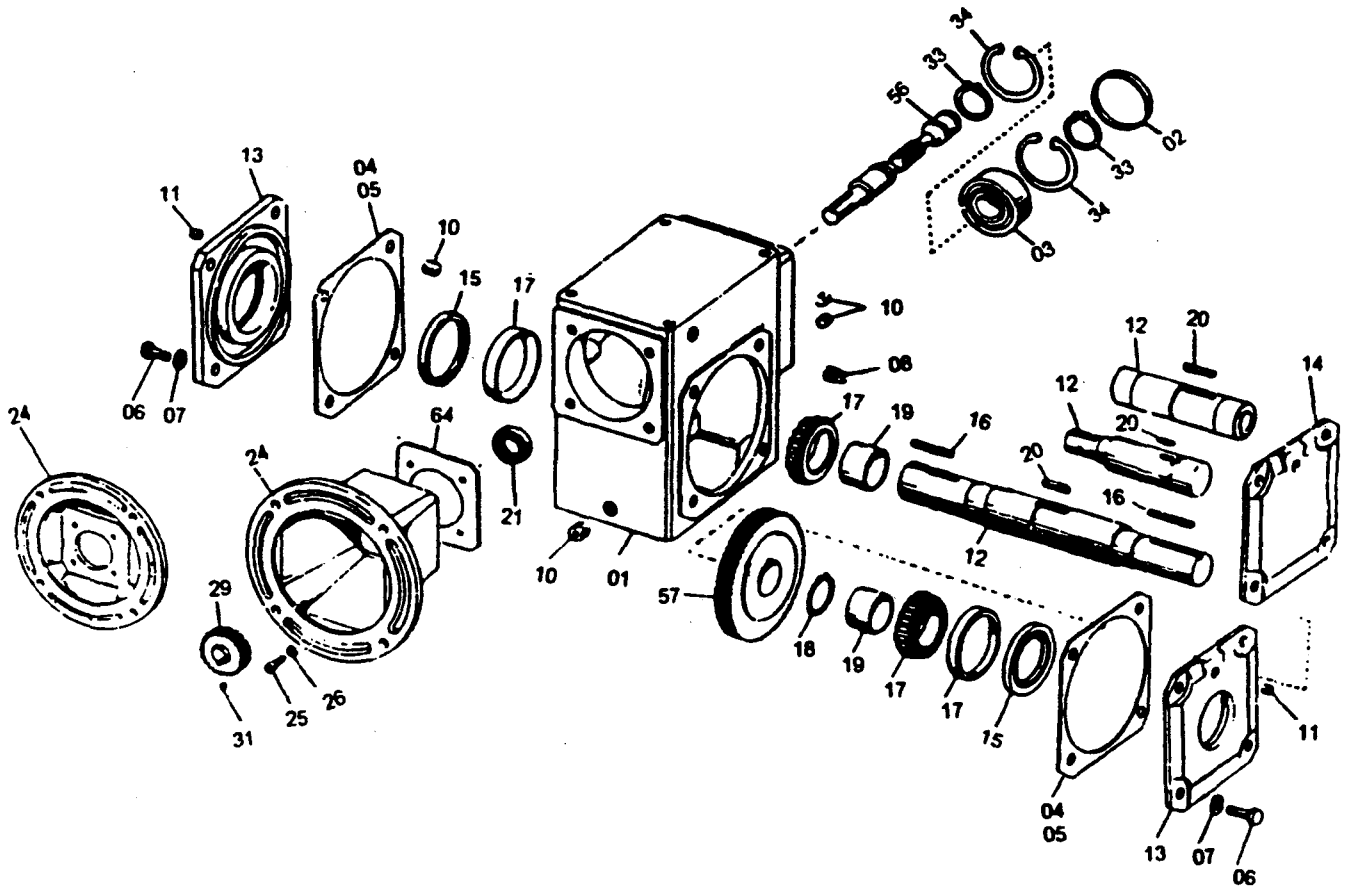

****NOTE** When ordering parts give complete name plate data.

*Refer to parts list in front of manual for gear box part number.

When Replacement Parts Are Needed, Order Only Yale® Factory Engineered Parts

OCTOBER 1994

EW SERIES

RT GEAR BOX

6462923** Series 133	
ITEM **	DESCRIPTION
644426-01	HOUSING
644426-02	END COVER
644426-03	BEARING
644426-04	SHIM (.019 THICK)
644426-05	SHIM (.007 THICK)
644426-06	CAPSCREW
644426-07	LOCKWASHER
644426-09	VENT PLUG
644426-10	PIPE PLUG
644426-11	PIPE PLUG
644426-12	OUTPUT SHAFT
644426-13	SEAL CAGE
644426-14	END COVER
644426-15	OIL SEAL
644426-16	KEY
644426-17	BEARING
644426-18	LOCK RING
644426-19	SPACER
644426-20	KEY
644426-21	OIL SEAL
644426-22	KEY
644426-24	MOTOR FLANGE
644426-25	CAPSCREW
644426-26	LOCKWASHER
644426-30	COUPLING HUB (MOTOR)
644426-31	SETSCREW
644426-33	LOCK RING
644426-34	LOCK RING
**-56	WORM - SEE CHART
**-57	GEAR - SEE CHART
644426-64	GASKET
NOTE: WHEN ORDERING REPLACEMENT PARTS, SPECIFY I.D. NUMBER, ITEM NUMBER AND PART DESCRIPTION.	

Worm & Gear

Ratio	Worm No.	Gear No.
5-1	6444706-01	6444706-02
10-1	6444706-03	6444706-04
15-1	6444706-05	6444706-06
20-1	6444706-07	6444706-08
30-1	6444706-09	6444706-10
40-1	6444706-11	6444706-12
50-1	6444706-13	6444706-14
60-1	6444706-15	6444706-16

When Replacement Parts Are Needed, Order Only Yale® Factory Engineered Parts

Yale Hoisting Equipment

TT SERIES 648943100 (Keyed shaft for RT trolley)
TROLLEY MOTOR 640585400 (Splined Shaft for ST & TT trolley)

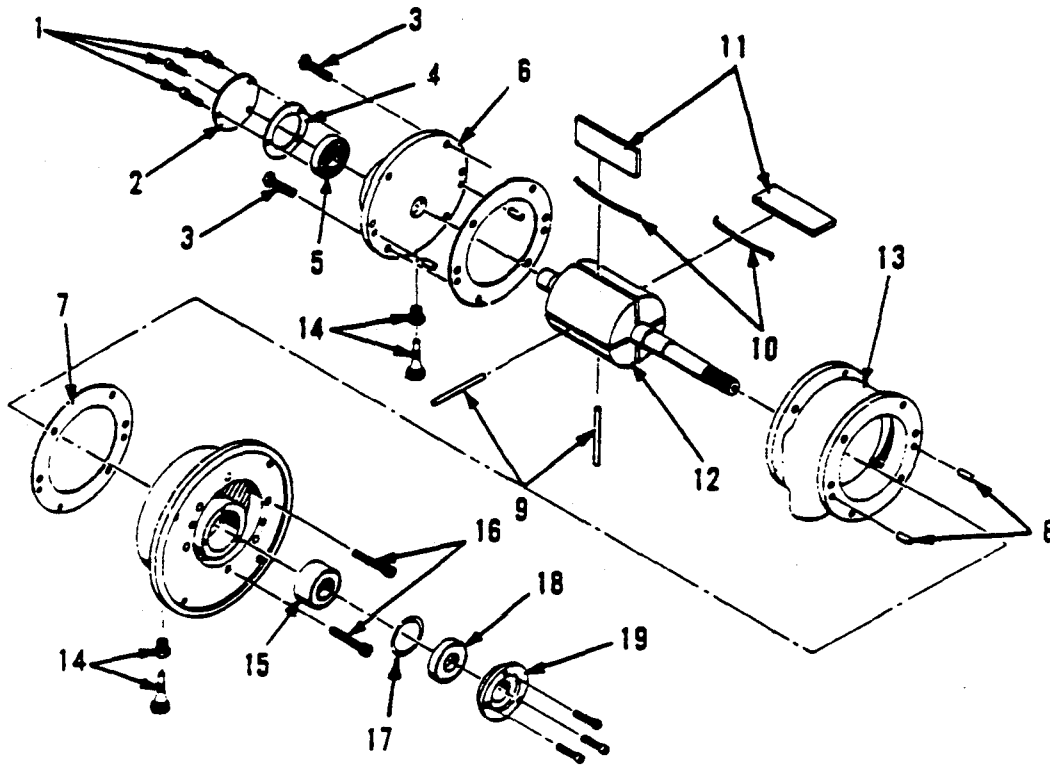

WHEN REPLACEMENT PARTS ARE NEEDED, ORDER ONLY YALE® FACTORY ENGINEERED PARTS

TT SERIES

51.5

REVISED MARCH 1996

Yale Hoisting Equipment

AIR MOTOR AND ADAPTER ASM.

TT Series (Air Powered)

ITEM	PART NO. 1/2 PIPE	DESCRIPTION	QTY.
1	6453748-00	SCREW	6
2	6421178-00	END CAP	1
3	6453758-00	SCREW	6
4	6421188-00	GASKET	1
5	6421088-00	BEARING	1
6	6421028-00	END PLATE	1
7	6421138-00	GASKET	2
8	6421128-00	DOWEL PIN	4
9	6421068-00	PUSH PIN	2
10	6421058-00	VANE SPRING	4
11	6421048-00	VANE	4
12	NOT AVAILABLE	ROTOR ASSEMBLY	1
13	6421008-00	BODY	1
14	6453768-00	OILER ASSEMBLY	2
15	6421078-00	BEARING	1
16	6453778-00	SCREW	6
17	6421198-00	"O" RING	1
18	6421118-00	SEAL	1
19	6421168-00	END CAP	1
20	6421228-00	REPAIR KIT (INCL. ITEMS 4, 5, 7, 9, 10, 11, 15, 17 & 18)	1
21	6414140-00	MOTOR ADAPTER ASM. (INCL. ITEMS 22 through 27)	1
22	6405083-00	MOTOR ADAPTER (NOT SHOWN)	1
23	0655796-00	SCREW (NOT SHOWN)	4
24	0515197-00	RETAINING RING (NOT SHOWN)	1
25	0325737-00	BEARING (NOT SHOWN)	1
26	0150290-00	LOCKWASHER (NOT SHOWN)	4
27	0150288-00	WASHER (NOT SHOWN)	4

When Replacement Parts Are Needed, Order Only Yale® Factory Engineered Parts

REPAIR PARTS



KAL Series Geared Trolley Assembly

PATENTED TRACK - 3 1/4 & 4 1/16 FLANGE-5/8 MAX. THICKNESS

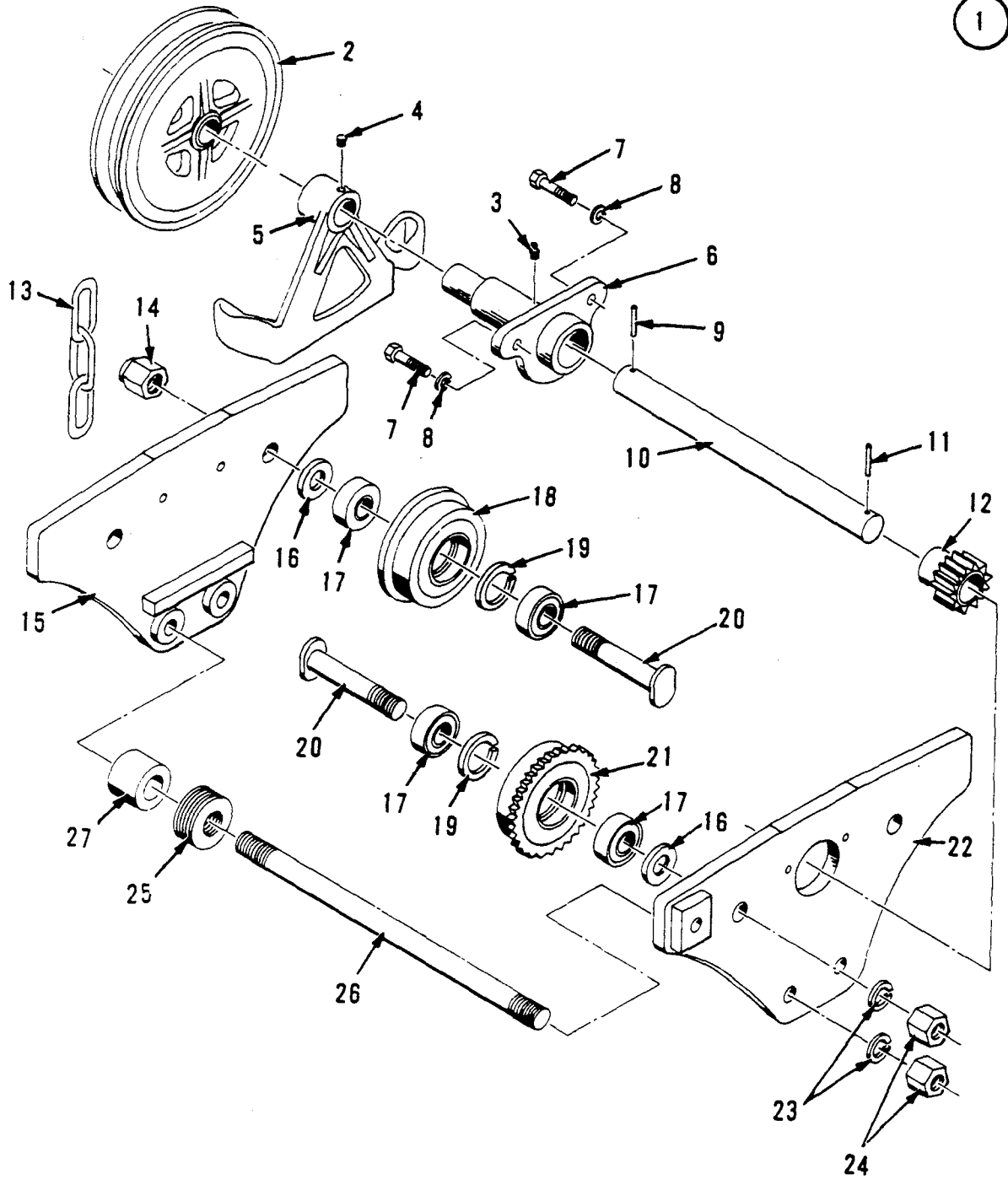

FIGURE 17

When Replacement Parts Are Needed, Order Only YALE® Factory Engineered Parts

KAL SERIES

Yale®

KAL Series Geared Trolley Assembly
Patented Track - 3 1/4 & 4 1/16 Flange - 5/8 Max. Thickness

Item Number	1/2, 1 & 2 Ton Part Number	3 Ton Part Number	Description	Qty.
1	6474570-00	5024390-00	Geared Trolley Assembly (Includes Items 3 thru 27)	1
2	0250218-00	0250218-00	Handwheel	1
3	0227845-00	0227845-00	Alemite Fitting	1
4	0156287-00	0156287-00	Alemite Fitting	1
5	0603328-00	0603328-00	Chain Guide	1
6	0603329-00	0646611-00	Extension Bracket	1
7	0570482-00	0570482-00	Hex Head Screw	2
8	0150264-00	0150264-00	Lockwasher	2
9	023027-00	0230207-00	Roll Pin	1
10	0603336-00	0646612-00	Shaft	1
11	0250666-00	0250666-00	Drive-Lok Pin	1
12	0250202-00	0250202-00	Pinion	1
13	0033730-00	0033730-00	Hand Chain (Specify Length)	1
14	0550157-00		Stover Nut	4
15	5018264-00	0664025-00	Trolley Side Plate, Plain	1
16	0114207-00	0665193-00	Spacer	4
17	0250647-00	0664037-00	Bearing Assembly	8
18	0650863-00	5018433-00	Trolley Wheel, Plain	2
19	*	0664040-00	Spacer	4
20	0650864-00	5024561-00	Axle	4
21	5011583-00	5018443-00	Trolley Wheel, Geared	2
22	5019274-00	0664027-00	Trolley Side Plate, Geared	1
23	0214111-00	0150297-00	Lockwasher	4***
24	0149374-00	0149716-00	Hex Nut	4***
25	0114200-00	0114197-00	Adjusting Washers	18***
26	0101017-00	0101053-00	Double End Stud	2
27		5000239-23	Spacer (DE,Stud)	4

* 1/2, 1 & 2 Ton Unit Uses A Retaining Ring Between The Wheel Bearings Part Number 6400469-04, 4 Required.

** Four (4) On 3 Ton.

*** Eight (8) On 3 Ton.

When Replacement Parts Are Needed, Order Only YALE® Factory Engineered Parts

Yale®

KAL-KAW Air Motor Disassembly And Repair Kit Installation

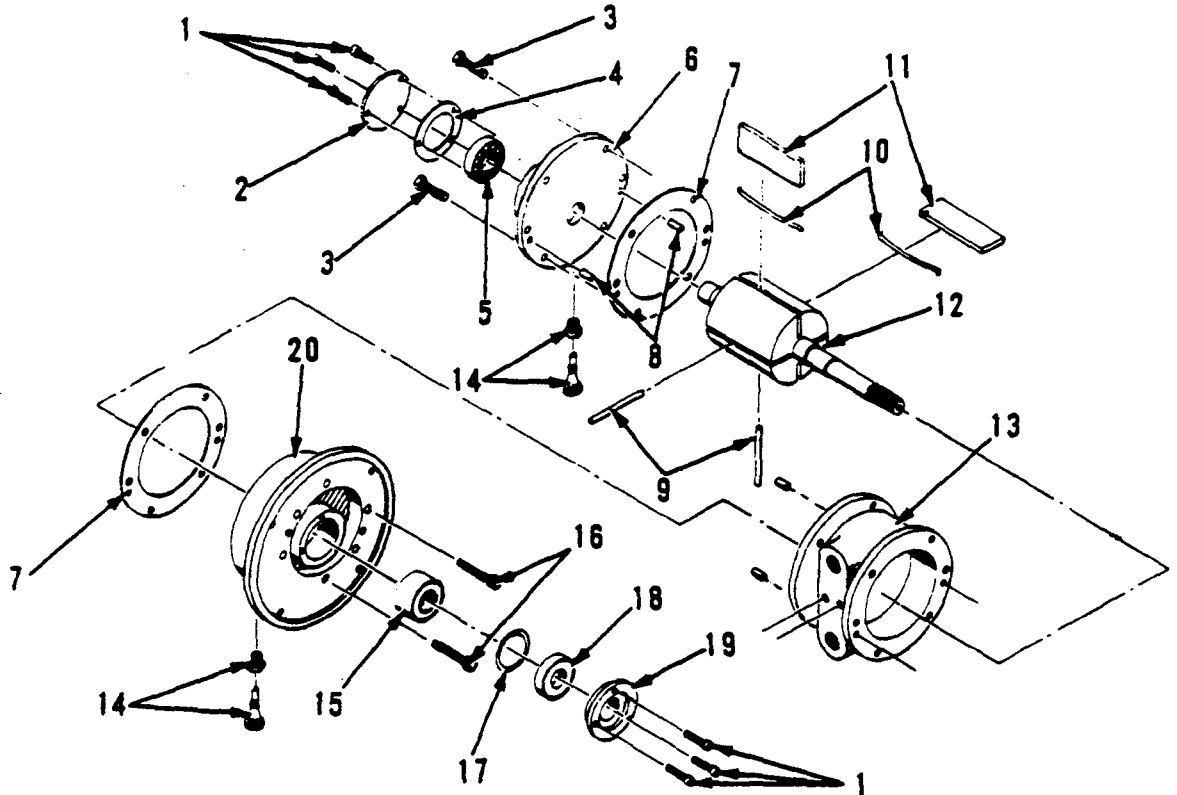

ITEM	DESCRIPTION	QTY.
	MOTOR ASSEMBLY	1
1	SCREW	6
2	END CAP	1
3	SCREW	6
*4	GASKET	1
*5	BEARING	1
6	END PLATE	1
*7	GASKET	2
8	DOWEL PIN	4
*9	PUSH PIN	2
*10	VANE SPRING	4
*11	VANE	4
12	ROTOR ASSEMBLY	1
13	BODY	1
14	OILER ASSEMBLY	2
*15	BEARING	1
16	SCREW	6
*17	"O" RING	1
*18	SEAL	1
19	END CAP	1
20	END PLATE	1

* These items are contained in motor repair kit #6453788-00 and should be replaced during reassembly.

When Replacement Parts Are Needed, Order Only YALE® Factory Engineered Parts

Yale Hoisting Equipment

AIR MOTOR AND ADAPTER ASSM.

TT Series (Air Powered)

Item	Part No. 1/2 Pipe	Description	Qty.
1	6453748-00	SCREW	6
2	6421178-00	END CAP	1
3	6453758-00	SCREW	6
4	6421188-00	GASKET	1
5	6421088-00	BEARING	1
6	6421028-00	END PLATE	1
7	6421138-00	GASKET	2
8	6421128-00	DOWEL PIN	4
9	6421068-00	PUSH PIN	2
10	6421058-00	VANE SPRING	4
11	6421048-00	VANE	4
12	Not Available	ROTOR ASSEMBLY	1
13	6421008-00	BODY	1
14	6453768-00	OILER ASSEMBLY	2
15	6421078-00	BEARING	1
16	6453778-00	SCREW	6
17	6421198-00	"O" RING	1
18	6421118-00	SEAL	1
19	6421168-00	END CAP	1
20	6421228-00	REP KIT(INCL. ITEMS 4,5,7,9,10,11,15,17,18)	1
21	6414140-00	MOTR ADAPT. ASM. (INC.ITEM 22 - 27)	1
22	6405083-00	MOTOR ADAPTER (NOW SHOWN)	1
23	0655796-00	SCREW (NOT SHOWN)	4
24	0515197-00	RETAINING RING (NOT SHOWN)	1
25	0325737-00	BEARING (NOT SHOWN)	1
26	0150290-00	LOCKWASHER (NOT SHOWN)	4
27	0150288-00	WASHER (NOT SHOWN)	4

When Replacement Parts Are Needed, Order Only YALE® Factory Engineered Parts

Yale Hoisting Equipment

REPAIR PARTS

MOTORIZED TROLLEY DRIVE (RT)

Trolley Assembly
4 7/8" Tread Diameter

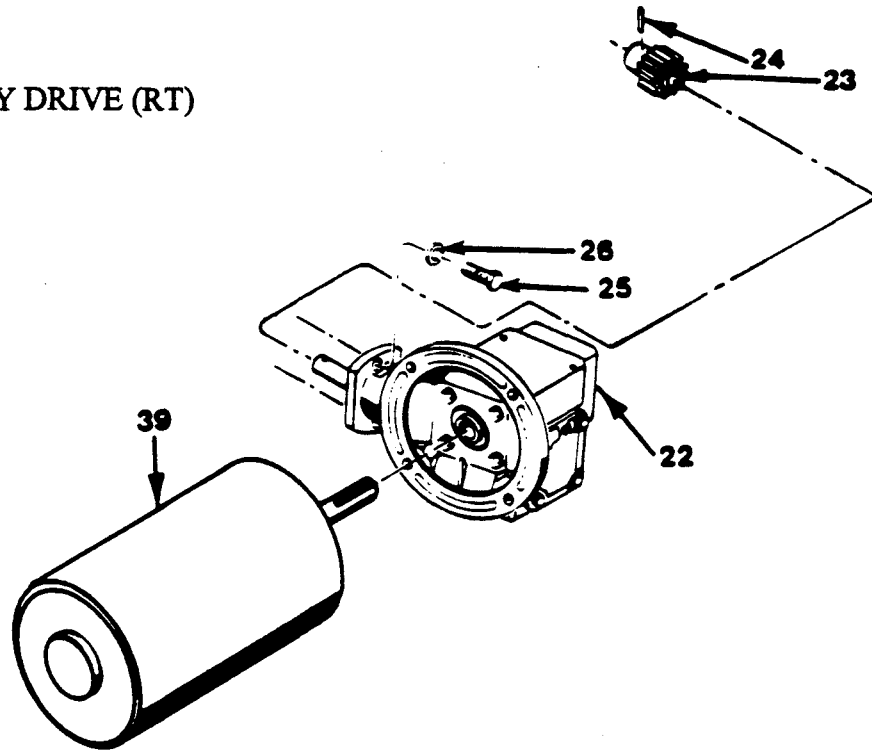

Item Nbr.	Part Number	Description	Qty.
22	SEE TABLE 6467002-00	GEAR CASE RT. MGT. KIT (INCL. 23,24,25 & 26)	1
23	6462883-00	PINION	1
24	6462973-01	GROOVE PIN	1
25	0554856-00	BOLT	2
26	0150266-00	LOCK WASHER	2
39	*	MOTOR	1

* When Ordering Motors Give Complete Data On Motor Nameplate.

GEAR TABLE

TRAVEL SPEED (FT/MIN)	GEAR CASE	RATIO
15	6462923-30	30:1
30	6462923-15	15:1
45	6462923-10	10:1
90	6462923-05	5:1

TT Series (Air Powered)

Control and Hose Assembly

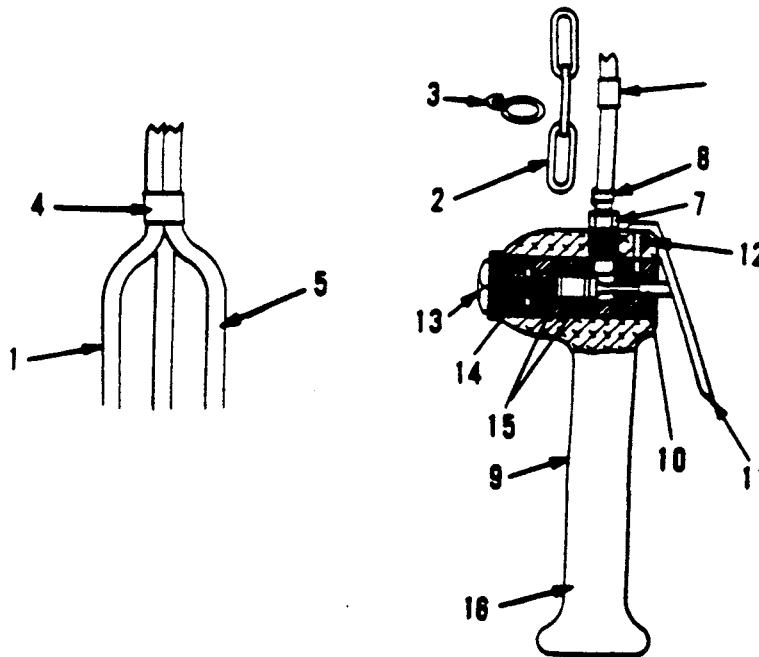

185-808-014

Item Number	Part Number	Description	Qty.
1	6414150-25	Hose Assm. (Incl. Items 2 thru 8)	1
2	0107222-00	Anchor Chain (Specify Length)	1
3	0107225-00	Hook	5
4	0612596-00	Hose Binder	3
5	6410078-81	Hose (Specify Length)	1
6	6410108-00	Hose Fitting (Not Shown)	3
7	6410118-00	Hose Fitting	3
8	6412118-00	Fasteners	6
9	6407204-00	Pendant Handle Assm. (Incl. Items 10 through 15)	1
10	6407204-03	Lower Valve Assembly	2
11	6407204-01	Throttle Lever	2
12	6407204-02	Throttle Lever Pin	1
13	6407204-06	Valve Cap	2
14	6407204-05	Valve Spring	2
15	6407204-04	Valve Seal Ring	4
16	6411820-00	Control Assembly (Incl. items 9 through 25)	1
17	0103737-00	Locknut (Not Shown)	4
18	0114200-00	Adjusting Washer (Not Shown)	4
19	5005019-11	Nipple (Not Shown)	1
20	5005019-12	Nipple (Not Shown)	2
21	5005019-14	Pipe (Not Shown)	2
22	6407374-00	Support (Not Shown)	1
23	6410028-00	Valve (Not Shown)	2
24	6410188-00	Bushing (Not Shown)	2
25	6412078-00	Elbow (Not Shown)	4

When Replacement Parts Are Needed, Order Only YALE® Factory Engineered Parts

-53D-

KAL SERIES

KL Series
Chain Containers (Metal)

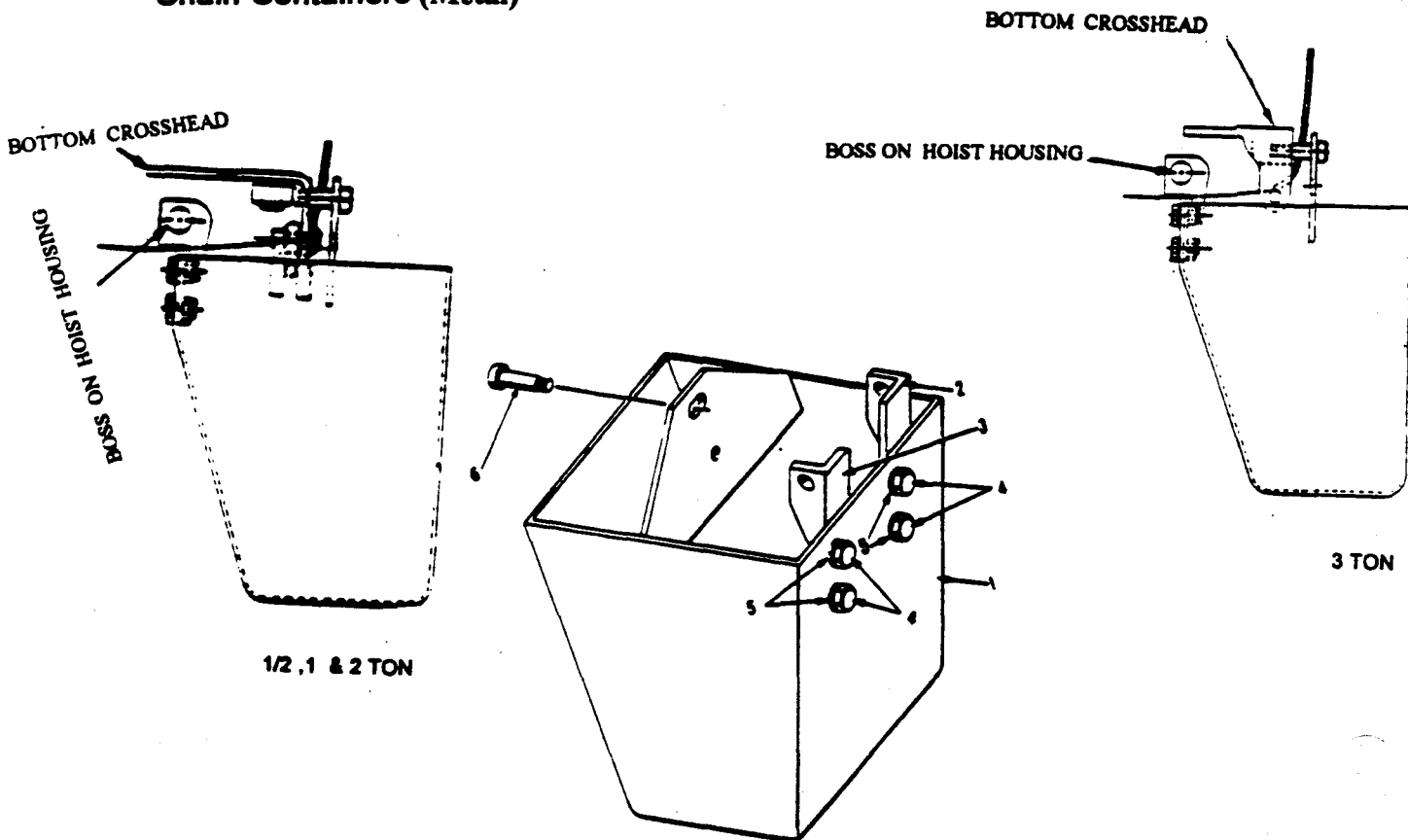

Figure 19

ITEM	1/2, 1 & 2 TON PART NUMBER	3 TON PART NUMBER	DESCRIPTION	QTY.
1	6420516-00		Chain Cont. Assy. (15 Ft. Cap.)	1
	6405647-00		Chain Cont. Assy. (25 Ft. Cap.)	1
	6405647-00	6410662-00	Chain Cont. Assy. (50 Ft. Cap.)	1
	6407867-00	6413762-00	Chain Cont. Assy. (75 Ft. Cap.)	1*
2	6469841-00	6455684-00	Lug (Left Hand)	1
3	6469831-00	6455694-00	Lug (Right Hand)	1
4	0597163-00	0597163-00	Hex Head Screw	4
5	0325860-00	0325860-00	Lockwasher	4
6	6402149-01	6402149-01	Shoulder Bolt	1

* Use on Right Angle Trolley Mounted Hoists Only.

INSTALLATION INSTRUCTIONS

1. Attach chain container to bottom crosshead as shown above.
2. Attach chain container to hoist by placing hanger bracket on bosses of hoist. Then attach hanger bracket to bottom crosshead with socket head shoulder bolt as shown above.
- 3.

For field conversion tap 5/16 - 18 hole in bottom crosshead (as shown above) and use 5/16 - 18 shoulder bolt to attach container. (HOLE TAP ONLY REQD. ON 1/2, 1, 2 and 3 TON UNITS).

When Replacement Parts Are Needed, Order Only YALE® Factory Engineered Parts

**KL SERIES (MOLDED)
CHAIN CONTAINERS**

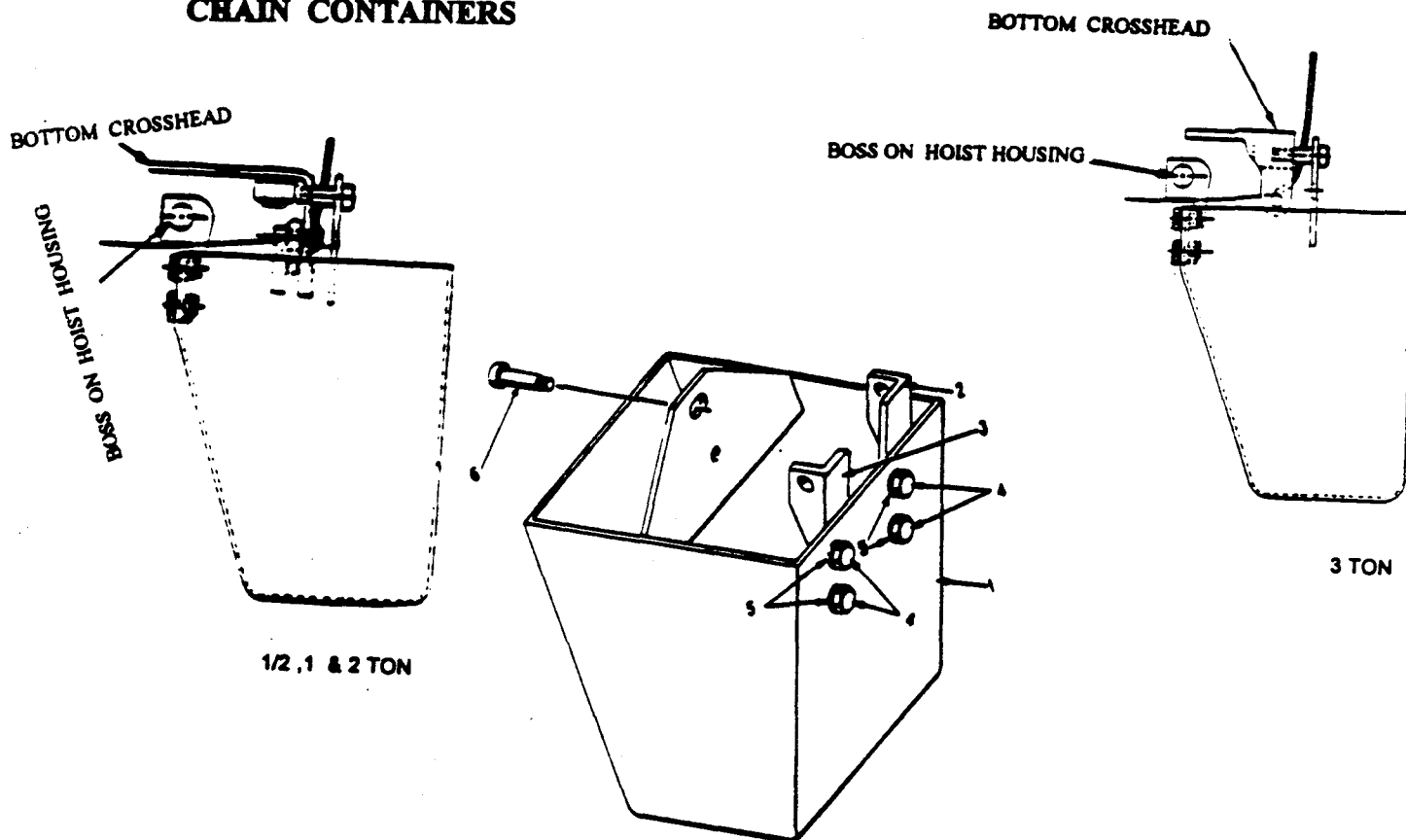

FIGURE 29

ITEM	1/2 TON THRU 3 TON PART NO.	DESCRIPTION	QTY.
1	6480592-00	CHAIN CONT. ASSY (50 FT. CAPACITY)	1
	6480592-01	CHAIN CONT. ASSY (75 FT. CAPACITY)	1*
2	6469841-00	LUG (RIGHT HAND)	1
3	6469831-00	LUG (LEFT HAND)	1
4	0597163-00	HEX HEAD SCREW	4
5	0161036-00	LOCKWASHER	4
6	6402149-02	SHOULDER BOLT	1

* Use on Right Angle Trolley Mounted Hoists Only.

INSTALLATION INSTRUCTIONS

1. Attach chain container to bottom crosshead as shown above.
2. Attach chain container to hoist by placing hanger bracket on bosses of hoist. Then attach hanger bracket to bottom crosshead with socket head socket shoulder bolt as shown above.
- 3.

For field conversion tap 5/16 - 18 hold in bottom crosshead (as shown above) and use 5/16 - 18 shoulder bolt to attach container. (HOLE TAP ONLY REQD. ON 1/2, and 2 TON UNITS).

When Replacement Parts Are Needed, Order Only Yale® Factory Engineered Parts

Yale[®] Hoists

KL CHAIN CONTAINERS (CANVAS BAG) INSTALLATION INSTRUCTIONS 1/2, 1 AND 2 TON CAPACITY

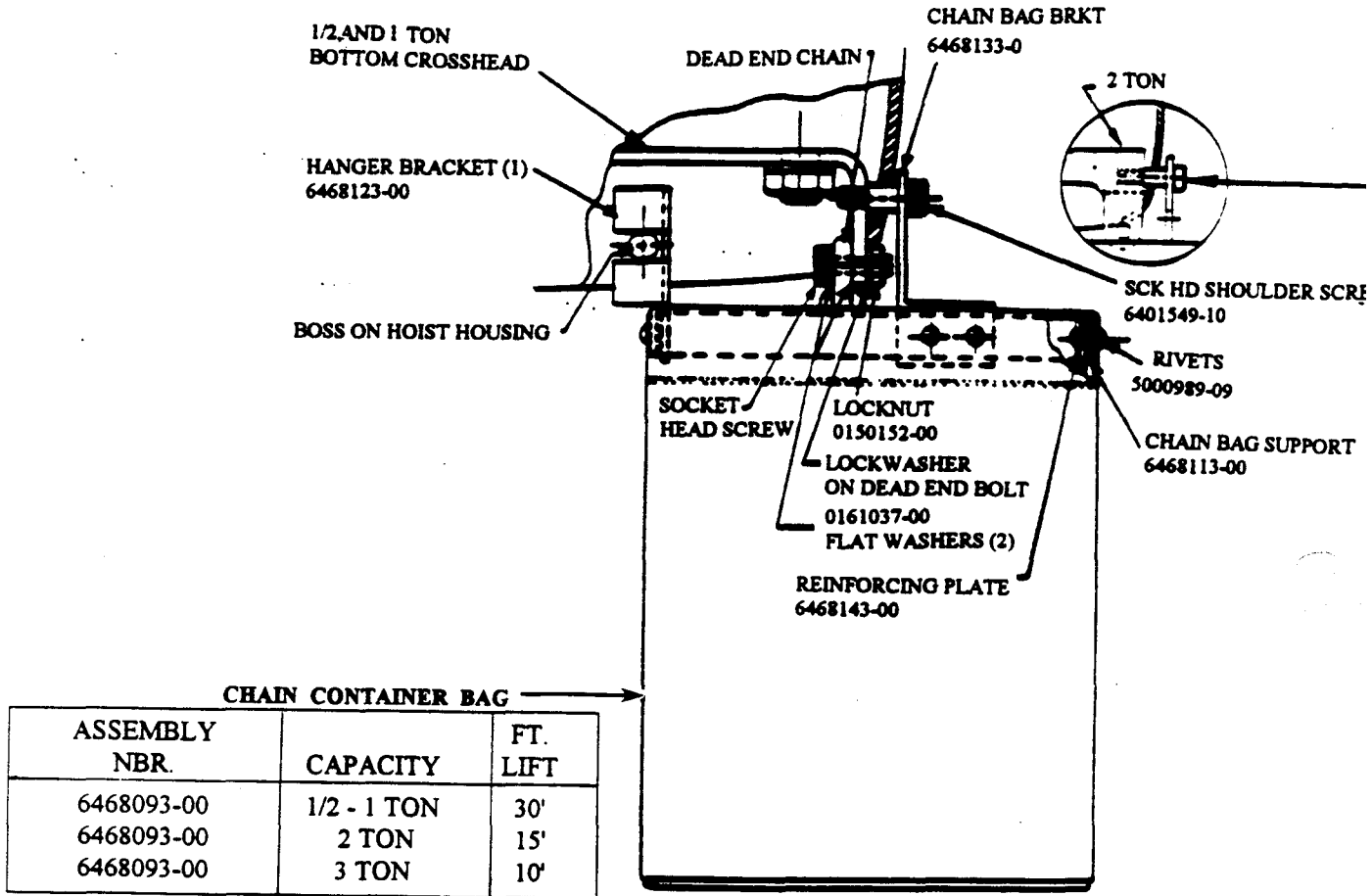

CAUTION

DO NOT TWIST CHAIN

1. Attach chain container to bottom crosshead as shown above.
2. Attach chain container to hoist by placing hanger bracket on bosses of hoist. Then attach hanger bracket to bottom crosshead with socket head socket shoulder bolt as shown above.
- 3.

For field conversion tap 5/16 - 18 hold in bottom crosshead (as shown above) and use 5/16 - 18 shoulder bolt to attach container. (HOLE TAP ONLY REQD. ON 1/2, and 2 TON UNITS).

When Replacement Parts Are Needed, Order Only Yale[®] Factory Engineered Parts

Yale

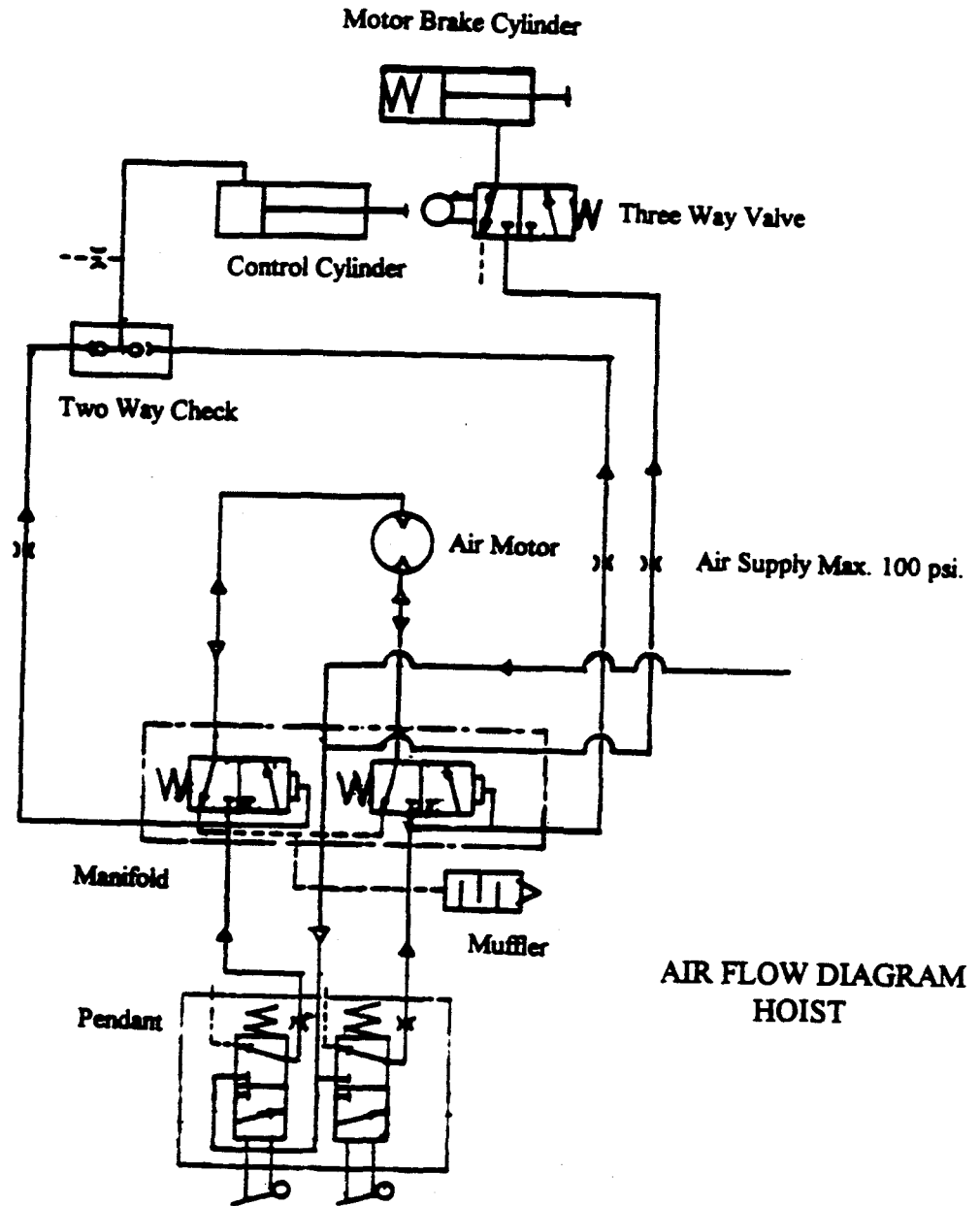

AIR FLOW DIAGRAM
HOIST

When Replacement Parts Are Needed, Order Only YALE® Factory Engineered Parts

Air Flow Diagram

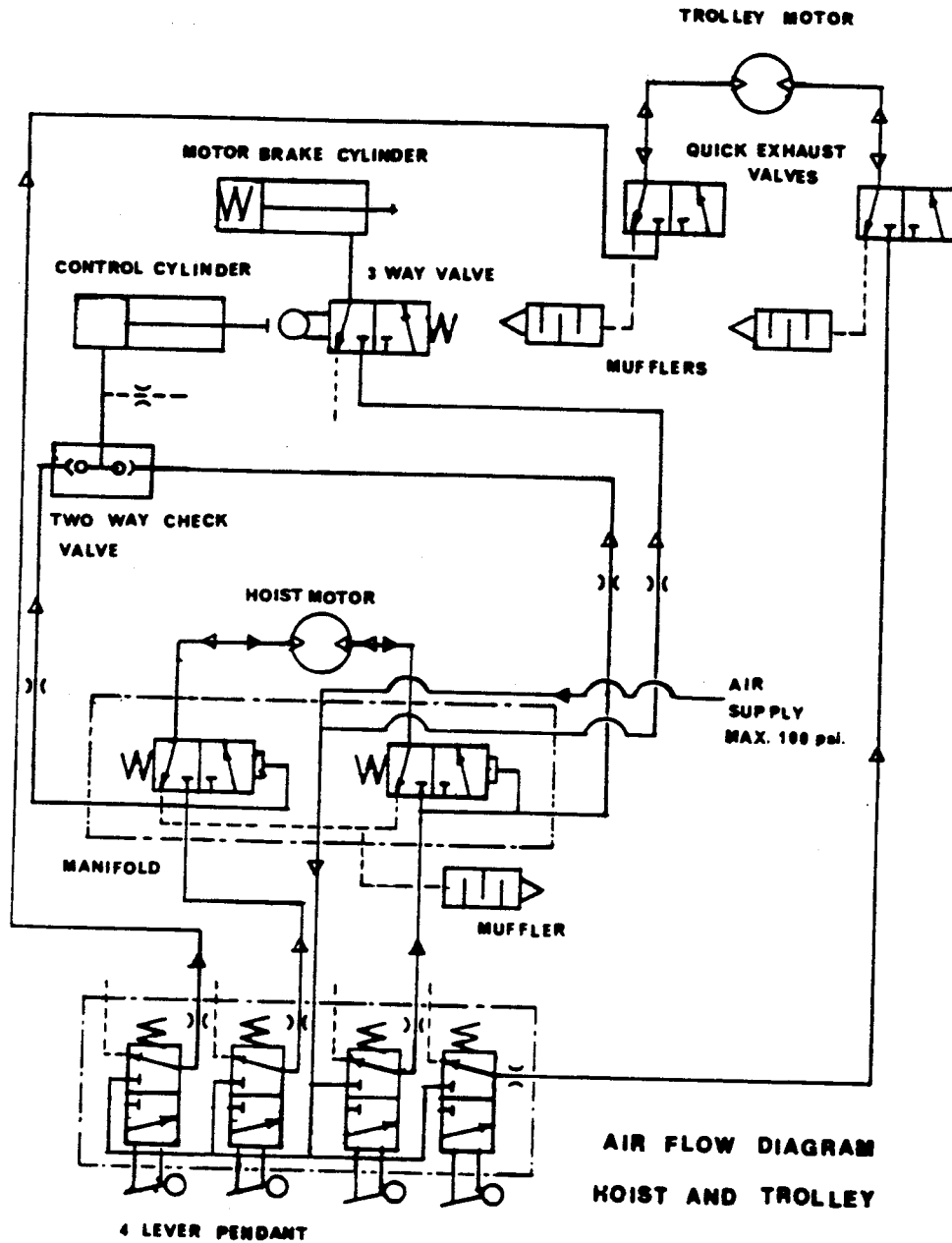

**AIR FLOW DIAGRAM
HOIST AND TROLLEY**

When Replacement Parts Are Needed, Order Only YALE® Factory Engineered Parts

KAL SERIES

Yale®

KAL-KAW Air Motor Disassembly And Repair Kit Installation Trouble Shooting

Trouble shooting an air motor is simple and straightforward. The majority of the symptoms of incorrect motor operation fall into three categories:

1. Motor inoperative.
2. Motor sluggish.
3. Motor inefficient.

The possible causes of the malfunctions are:

- a. Motor dirty.
 - b. Muffler stopped up.
 - c. Foreign particles in motor chamber.
 - d. Vanes worn out.
 - e. Air lines broken or obstructed.
 - f. External component malfunction (valve, etc.,)
- a. Motor dirty: Flush with solvent in well ventilated area. To flush, shut off air supply, disconnect air line and muffler and add several teaspoonfuls of solvent. Rotate the shaft by hand in both directions for several minutes. Connect air supply and apply pressure slowly until all solvent is exhausted.

WARNING

KEEP FACE AWAY FROM EXHAUST DURING FLUSHING OPERATION.

- b. Muffler stopped up: Check muffler felts for grease, oil, dirt, etc., Wash with solvent.
- c. Foreign particles in motor chamber: Disassemble motor, remove foreign particles, install motor repair kit.
- d. Vanes worn out: Install motor repair kit.
- e. Air lines broken or obstructed: Repair as necessary.
- f. External component malfunction: Repair or replace as necessary.

Note: Loctite Safety Solvent, Inhibisol Safety Solvent, Dow Chemical Chlorothane, or Kerosene.

When Replacement Parts Are Needed, Order Only YALE® Factory Engineered Parts

Yale®

KAL-KAW Air Motor Disassembly And Repair Kit Installation MOTOR REMOVAL

1. Loosen and remove all fittings from motor.
2. Remove the four hex-head screws from the flange of the motor and carefully remove the motor.

DISASSEMBLY

Note: Only an experienced mechanic with the proper tools should attempt air motor disassembly. To avoid damage to surfaces, do not pry any parts with screwdrivers, and do not hammer on motor shaft. Make sure all surfaces are clean and free of niches and burrs before reassembly.

1. Remove Drive Shaft Coupling (use puller if necessary). Avoid damaging serration's on drive shaft or coupling.
2. Remove Plate (20) from drive end of motor.
 - a. Remove the six recessed socket head screws (16).
 - b. Use puller to remove plate. Do not hammer on motor shaft.
3. Remove and cap (19) from plate (20).
 - a. Remove the three Philip head screws (1) and remove end cap 919).
 - b. Remove O-Ring (17) and Seal (18) from end cap (19).
 - c. Remove bearing (15) from end plate (20).
 - d. Thoroughly clean end plate and cap with solvent.
4. Rotor removal.
 - a. Remove end cap (2) and gasket (4).
 - b. Use puller or press to push out Rotor Shaft (12). Care should be taken to avoid damaging components.
 - c. Remove bearing (5) from end plate (6).
 - d. Remove hex-head screws (3) from end plate (6) and remove end plate from body (13).
 - e. Remove vanes (11) and vane springs (10) from rotor.
 - f. Remove push pins (9) from rotor.
 - g. Thoroughly clean rotor, end plate and body with solvent.

When Replacement Parts Are Needed, Order Only YALE® Factory Engineered Parts

KAL-KAW Air Motor Disassembly and Repair Kit Installation Reassembly

Note: Complete motor repair kit should be installed during reassembly.

1. Install new onionskin gasket (7) on end plate (6).
2. Attach end plate (6) to body (13) with six hex-head screws (3).
3. Install new push pins (9) into rotor.
4. Install rotor into body.
5. Press new bearing (5) onto rotor shaft while supporting the opposite drive end of shaft rigidly. Make sure rotor turns freely after bearing installation.
6. Install new vanes and vane springs. The notch on the vanes should be at the end opposite the drive end. Curved portion of the springs should be against the bottom of the rotor slots.
7. Install new onionskin gasket (7) on body.
8. Install end plate (20) on drive end of motor and secure with the six recessed socket head screws.
9. Install a new O-Ring (17) and seal (18) in end cap (19). Lubricate seal and O-Ring lightly.
10. Press new bearing (15) into place on drive shaft. Make sure rotor turns freely after bearing installation.
11. Install end cap (19) and secure with the three Philip head screws (1).
12. Install end plate (2) with new gasket (4) on motor.
13. Carefully press drive shaft coupling onto motor shaft.
14. Lubricate motor and make sure it rotates freely in both directions before installing.

When Replacement Parts Are Needed, Order Only YALE® Factory Engineered Parts



KAL-KAW Air Motor DISASSEMBLY AND REPAIR KIT INSTALLATION

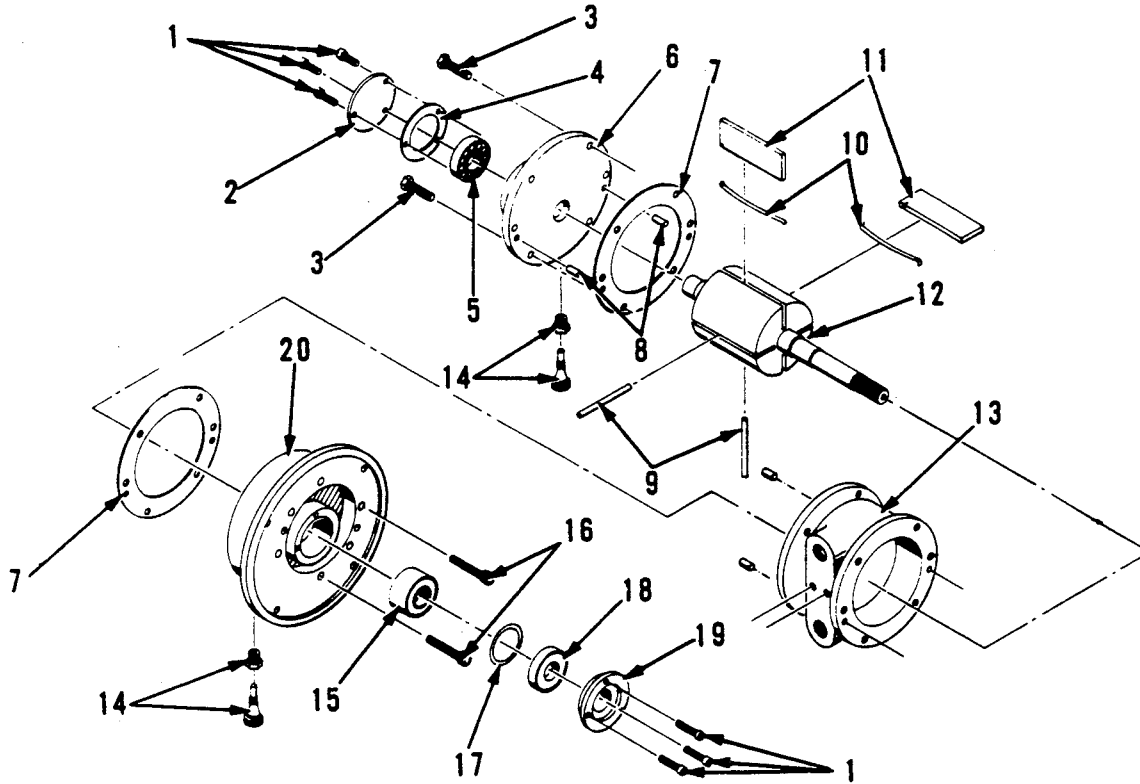

ITEM	DESCRIPTION	QTY
	MOTOR ASSEMBLY	1
1	SCREW	6
2	END CAP	1
3	SCREW	6
* 4	GASKET	1
* 5	BEARING	1
6	END PLATE	1
* 7	GASKET	2
8	DOWEL PIN	4
* 9	PUSH PIN	2
* 10	VANE SPRING	4
* 11	VANE	4
12	ROTOR ASSEMBLY	1
13	BODY	1
14	OILER ASSEMBLY	2
* 15	BEARING	1
16	SCREW	6
* 17	"O" RING	1
* 18	SEAL	1
19	END CAP	1
20	END PLATE	1

* These items are contained in motor repair kit #6453788-00 and should be replaced during reassembly.

When Replacement Parts Are Needed, Order Only YALE® Factory Engineered Parts

POWERED HOIST INSPECTION CHECK LIST

SEE PREVENTIVE MAINTENANCE SECTION OF INSTRUCTION MANUAL FOR DETAILS.

CHECK ONLY COMPONENTS APPLICABLE FOR SPECIFIC EQUIPMENT AND INSPECTION TYPE.

HOIST MODEL _____

HOIST S/N _____

HOOKS	YES	NO	CABLE	YES	NO	CHAINS	YES	NO
HARDWARE LOOSE	<input type="checkbox"/>	<input type="checkbox"/>	BROKEN WIRES AT ENDS	<input type="checkbox"/>	<input type="checkbox"/>	BINDING	<input type="checkbox"/>	<input type="checkbox"/>
CRACKS	<input type="checkbox"/>	<input type="checkbox"/>	BROKEN WIRES EXCESSIVE	<input type="checkbox"/>	<input type="checkbox"/>	CRACKED	<input type="checkbox"/>	<input type="checkbox"/>
EXCESSIVE WEAR	<input type="checkbox"/>	<input type="checkbox"/>	EXCESSIVE WEAR	<input type="checkbox"/>	<input type="checkbox"/>	TWISTED	<input type="checkbox"/>	<input type="checkbox"/>
BENT	<input type="checkbox"/>	<input type="checkbox"/>	KINKED OR DISTORTED	<input type="checkbox"/>	<input type="checkbox"/>	DISTORTED	<input type="checkbox"/>	<input type="checkbox"/>
SPREADING	<input type="checkbox"/>	<input type="checkbox"/>	CORROSION	<input type="checkbox"/>	<input type="checkbox"/>	CORRODED	<input type="checkbox"/>	<input type="checkbox"/>
FREELY ROTATE	<input type="checkbox"/>	<input type="checkbox"/>	HEAT DAMAGED	<input type="checkbox"/>	<input type="checkbox"/>	EXCESSIVE WEAR	<input type="checkbox"/>	<input type="checkbox"/>
LATCH DAMAGED	<input type="checkbox"/>	<input type="checkbox"/>				WORN CHAIN GUIDES	<input type="checkbox"/>	<input type="checkbox"/>
						POCKET WHEELS WORN	<input type="checkbox"/>	<input type="checkbox"/>
BRAKES			WIRING			DRUM & SHEAVES		
MOTOR BRAKE WORN OR NOT OPERATING	<input type="checkbox"/>	<input type="checkbox"/>	LOOSE CONNECTIONS	<input type="checkbox"/>	<input type="checkbox"/>	WORN EXCESSIVELY	<input type="checkbox"/>	<input type="checkbox"/>
EXCESSIVE LOADBRAKE DRIFT OR BLACKLASH	<input type="checkbox"/>	<input type="checkbox"/>	FRAYED	<input type="checkbox"/>	<input type="checkbox"/>	CRACKED OR SCORED	<input type="checkbox"/>	<input type="checkbox"/>
EXCESSIVE DISC WEAR	<input type="checkbox"/>	<input type="checkbox"/>	DAMAGED	<input type="checkbox"/>	<input type="checkbox"/>			
			PROPER GROUNDING	<input type="checkbox"/>	<input type="checkbox"/>			
LIMIT SWITCHES			LOAD LIMITING DEVICE			COLLECTORS		
OPERATING PROPERLY	<input type="checkbox"/>	<input type="checkbox"/>	OPERATING PROPERLY	<input type="checkbox"/>	<input type="checkbox"/>	BINDING	<input type="checkbox"/>	<input type="checkbox"/>
						EXCESSIVE WEAR	<input type="checkbox"/>	<input type="checkbox"/>
HOUSING			OPERATION CONTROLS			LUBRICATION		
DISTORTED	<input type="checkbox"/>	<input type="checkbox"/>	CONTACTOR PITTING	<input type="checkbox"/>	<input type="checkbox"/>	ALL POINTS LUBRICATED AS GIVEN IN LUB CHART	<input type="checkbox"/>	<input type="checkbox"/>
CRACKS	<input type="checkbox"/>	<input type="checkbox"/>	OPERATING PROPERLY	<input type="checkbox"/>	<input type="checkbox"/>	OIL DARK OR LOW	<input type="checkbox"/>	<input type="checkbox"/>
LOOSE HARDWARE	<input type="checkbox"/>	<input type="checkbox"/>	DAMAGED PUSH BUTTON	<input type="checkbox"/>	<input type="checkbox"/>	OIL LEAKS	<input type="checkbox"/>	<input type="checkbox"/>
BEARING NOISE	<input type="checkbox"/>	<input type="checkbox"/>	HOUSING	<input type="checkbox"/>	<input type="checkbox"/>			
SUPPORTING STRUCTURE			AIR SYSTEM			WARNING LABELS		
CONTINUED ABILITY TO SUPPORT IMPOSED LOADS	<input type="checkbox"/>	<input type="checkbox"/>	LEAKING	<input type="checkbox"/>	<input type="checkbox"/>	MISSING	<input type="checkbox"/>	<input type="checkbox"/>
WORN OR DISTORTED TROLLEY PARTS	<input type="checkbox"/>	<input type="checkbox"/>	LOOSE CONNECTIONS	<input type="checkbox"/>	<input type="checkbox"/>	ILLEGIBLE	<input type="checkbox"/>	<input type="checkbox"/>
			BROKEN CONTROL PENDANT	<input type="checkbox"/>	<input type="checkbox"/>			

NOTE: IF ANY () IS CHECKED DO NOT OPERATE THE HOIST UNTIL REPAIRS HAVE BEEN MADE.

REMARKS AND REPAIRS MADE _____

SIGNATURE _____ DATE _____ CLOCK NUMBER _____

POWERED HOIST INSPECTION CHECK LIST

SEE PREVENTIVE MAINTENANCE SECTION OF INSTRUCTION MANUAL FOR DETAILS.

CHECK ONLY COMPONENTS APPLICABLE FOR SPECIFIC EQUIPMENT AND INSPECTION TYPE.

HOIST MODEL _____

HOIST S/N _____

HOOKS	YES	NO	CABLE	YES	NO	CHAINS	YES	NO
HARDWARE LOOSE	<input type="checkbox"/>	<input type="checkbox"/>	BROKEN WIRES AT ENDS	<input type="checkbox"/>	<input type="checkbox"/>	BINDING	<input type="checkbox"/>	<input type="checkbox"/>
CRACKS	<input type="checkbox"/>	<input type="checkbox"/>	BROKEN WIRES EXCESSIVE	<input type="checkbox"/>	<input type="checkbox"/>	CRACKED	<input type="checkbox"/>	<input type="checkbox"/>
EXCESSIVE WEAR	<input type="checkbox"/>	<input type="checkbox"/>	EXCESSIVE WEAR	<input type="checkbox"/>	<input type="checkbox"/>	TWISTED	<input type="checkbox"/>	<input type="checkbox"/>
BENT	<input type="checkbox"/>	<input type="checkbox"/>	KINKED OR DISTORTED	<input type="checkbox"/>	<input type="checkbox"/>	DISTORTED	<input type="checkbox"/>	<input type="checkbox"/>
SPREADING	<input type="checkbox"/>	<input type="checkbox"/>	CORROSION	<input type="checkbox"/>	<input type="checkbox"/>	CORRODED	<input type="checkbox"/>	<input type="checkbox"/>
FREELY ROTATE	<input type="checkbox"/>	<input type="checkbox"/>	HEAT DAMAGED	<input type="checkbox"/>	<input type="checkbox"/>	EXCESSIVE WEAR	<input type="checkbox"/>	<input type="checkbox"/>
LATCH DAMAGED	<input type="checkbox"/>	<input type="checkbox"/>				WORN CHAIN GUIDES	<input type="checkbox"/>	<input type="checkbox"/>
						POCKET WHEELS WORN	<input type="checkbox"/>	<input type="checkbox"/>
BRAKES			WIRING			DRUM & SHEAVES		
MOTOR BRAKE WORN OR NOT OPERATING	<input type="checkbox"/>	<input type="checkbox"/>	LOOSE CONNECTIONS	<input type="checkbox"/>	<input type="checkbox"/>	WORN EXCESSIVELY	<input type="checkbox"/>	<input type="checkbox"/>
EXCESSIVE LOADBRAKE DRIFT OR BLACKLASH	<input type="checkbox"/>	<input type="checkbox"/>	FRAYED	<input type="checkbox"/>	<input type="checkbox"/>	CRACKED OR SCORED	<input type="checkbox"/>	<input type="checkbox"/>
EXCESSIVE DISC WEAR	<input type="checkbox"/>	<input type="checkbox"/>	DAMAGED	<input type="checkbox"/>	<input type="checkbox"/>			
			PROPER GROUNDING	<input type="checkbox"/>	<input type="checkbox"/>			
LIMIT SWITCHES			LOAD LIMITING DEVICE			COLLECTORS		
OPERATING PROPERLY	<input type="checkbox"/>	<input type="checkbox"/>	OPERATING PROPERLY	<input type="checkbox"/>	<input type="checkbox"/>	BINDING	<input type="checkbox"/>	<input type="checkbox"/>
						EXCESSIVE WEAR	<input type="checkbox"/>	<input type="checkbox"/>
HOUSING			OPERATION CONTROLS			LUBRICATION		
DISTORTED	<input type="checkbox"/>	<input type="checkbox"/>	CONTACTOR PITTING	<input type="checkbox"/>	<input type="checkbox"/>	ALL POINTS LUBRICATED AS GIVEN IN LUB CHART	<input type="checkbox"/>	<input type="checkbox"/>
CRACKS	<input type="checkbox"/>	<input type="checkbox"/>	OPERATING PROPERLY	<input type="checkbox"/>	<input type="checkbox"/>	OIL DARK OR LOW	<input type="checkbox"/>	<input type="checkbox"/>
LOOSE HARDWARE	<input type="checkbox"/>	<input type="checkbox"/>	DAMAGED PUSH BUTTON HOUSING	<input type="checkbox"/>	<input type="checkbox"/>	OIL LEAKS	<input type="checkbox"/>	<input type="checkbox"/>
BEARING NOISE	<input type="checkbox"/>	<input type="checkbox"/>						
SUPPORTING STRUCTURE			AIR SYSTEM			WARNING LABELS		
CONTINUED ABILITY TO SUPPORT IMPOSED LOADS	<input type="checkbox"/>	<input type="checkbox"/>	LEAKING	<input type="checkbox"/>	<input type="checkbox"/>	MISSING	<input type="checkbox"/>	<input type="checkbox"/>
WORN OR DISTORTED TROLLEY PARTS	<input type="checkbox"/>	<input type="checkbox"/>	LOOSE CONNECTIONS	<input type="checkbox"/>	<input type="checkbox"/>	ILLEGIBLE	<input type="checkbox"/>	<input type="checkbox"/>
			BROKEN CONTROL PENDANT	<input type="checkbox"/>	<input type="checkbox"/>			

NOTE: IF ANY () IS CHECKED DO NOT OPERATE THE HOIST UNTIL REPAIRS HAVE BEEN MADE.

REMARKS AND REPAIRS MADE _____

SIGNATURE _____ DATE _____ CLOCK NUMBER _____

WARRANTY

Every hoist is thoroughly inspected and tested prior to shipment from the factory. Should any problems develop, return the complete hoist prepaid to your nearest Yale Hoists Authorized Warranty Repair Station.

This warranty does not apply where: (1) deterioration is caused by normal wear, abuse, improper or inadequate power supply, eccentric or side loading, overloading, chemical or abrasive actions, improper maintenance or excessive heat; (2) problems resulted from repairs, modifications or

alterations made by persons other than factory or Yale Hoists personnel; (3) the hoist has been abused or damaged as a result of an accident; (4) repair parts or accessories other than those supplied by Yale Hoists are used on the hoist. Equipment and accessories not of the seller's manufacture are warranted only to the extent that they are warranted by the manufacturer. EXCEPT AS STATED HEREIN, YALE HOISTS MAKES NO OTHER WARRANTIES, EXPRESS OR IMPLIED, INCLUDING WARRANTIES OF MERCHANTABILITY AND FITNESS FOR A PARTICULAR PURPOSE.

Improvements:

Yale Hoists is constantly striving to improve its product. Changes in design and improvements will be made whenever manufacturer believes the efficiency of the product will be improved without incurring any obligation to incorporate such improvements in any products which have been shipped or are in service.

Important Notice:

Use of chain, wire rope or replacement parts other than as supplied as original equipment on Yale hoists may lead to dangerous operation. Accordingly, Yale Hoists cannot be responsible in such cases and our warranty will be voided.

For more information, write Yale Hoists, Forrest City, Arkansas 72335.

Yale® HOISTS
3105 N. Washington
P. O. Box 1000
Forrest City, Arkansas 72335
Customer Service (800) 999-6318
FAX (800) 766-0223