

JLTX

Lever and Joystick Replacement Instructions



WARNING

THE INCORRECT INSTALLATION OF A LEVER OR JOYSTICK CAN CAUSE AN EQUIPMENT MALFUNCTION FAILURE TO FOLLOW THIS PROCEDURE CAREFULLY COULD RESULT IN SERIOUS INJURY OR DEATH AND DAMAGE TO EQUIPMENT.

It is strongly recommended the Telemotive repair department perform the lever and joystick replacement if possible. If not possible, please contact Technical Support for the part number of the specific lever or joystick replacement kit for your product.

READ THROUGH THE ENTIRE PROCEDURE COMPLETELY BEFORE ATTEMPTING REPAIRS. IF YOU DO NOT UNDERSTAND ANY PORTION OF THIS MANUAL, CALL TELEMOTIVE BEFORE ATTEMPTING TO SERVICE.

Call Magnetek Toll Free at 1-866-MAG-SERV (1-866-624-7378) and ask for Technical Support. For Canadian customers, please call Canada Service at 1-800-792-7253.

NOTE SPECIAL TOOLS REQUIRED: Small (magnetic tip preferred) and medium sized Phillips screwdriver for housing bottom and logic board mounting bracket removal. A pliers might be necessary to remove a toggle switch if needed. TORX® tip drivers number T7 for levers and T9 or T10 for joysticks. (A small Phillips driver will not remove a TORX screw. Most hardware stores and SEARS carries these types of drivers individually. SEARS has a screwdriver set that has both drivers the description is “SEARS/Craftsman 12-pc. Micro-Tech Expert Screwdriver Set part # 241670”).



TORX bit shape.

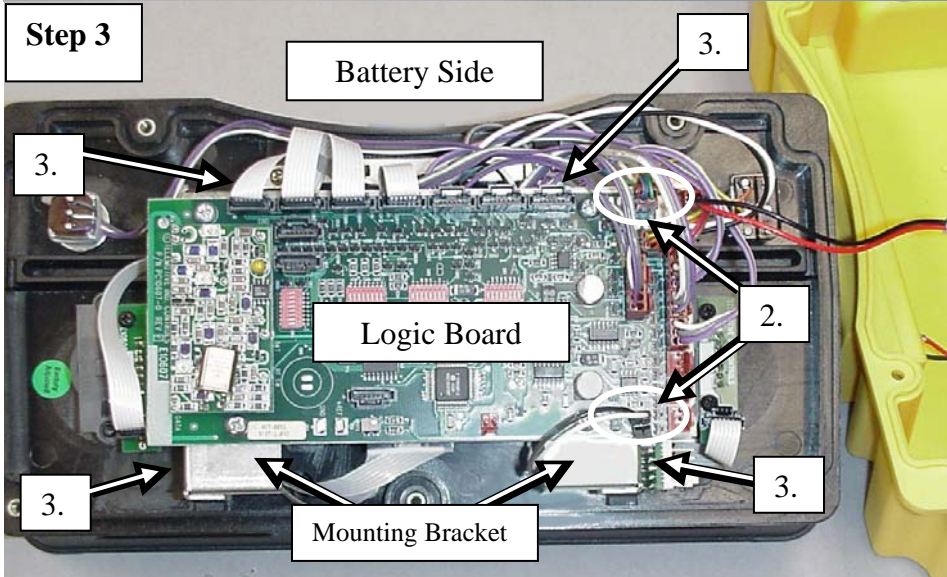
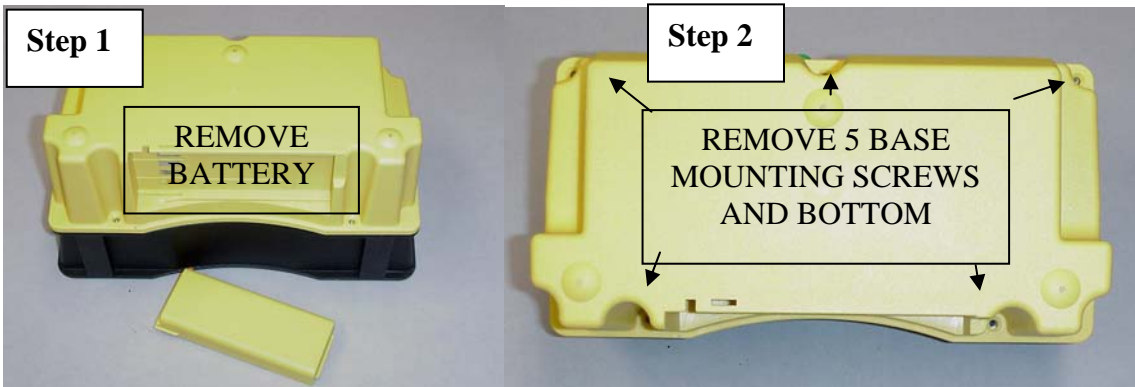

1. Mark the ALL the cables with an ID number. Mark the same ID number below on the chart for reference in re-assembly.

2. Remove J20 Battery (attached to bottom housing) and J1 LED cables. See diagram below for location.

3. Remove the four bracket mounting screws. See arrows and photos on next page.

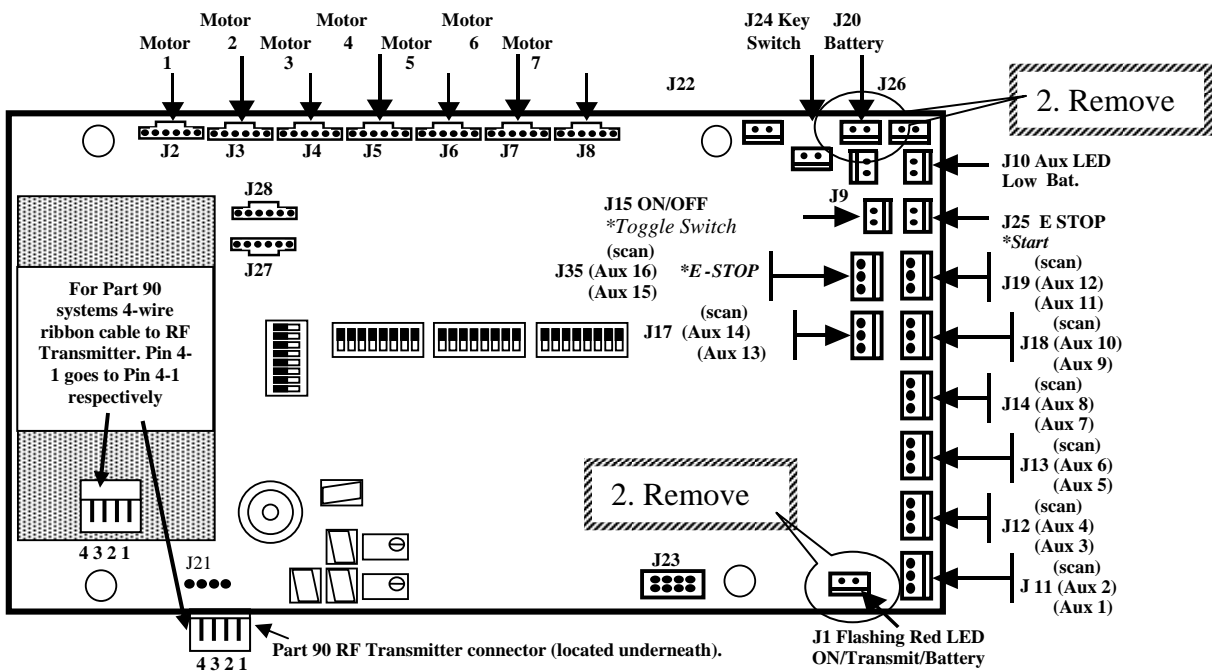

NOTE ALL CABLE LOCATIONS ON THIS CHART BEFORE DISASSEMBLING.

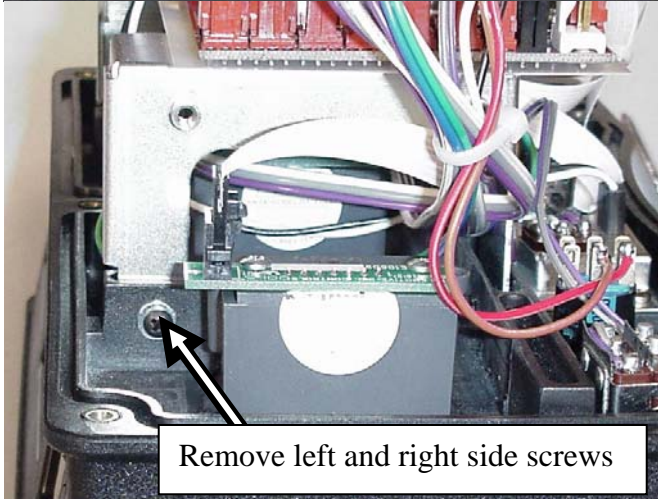
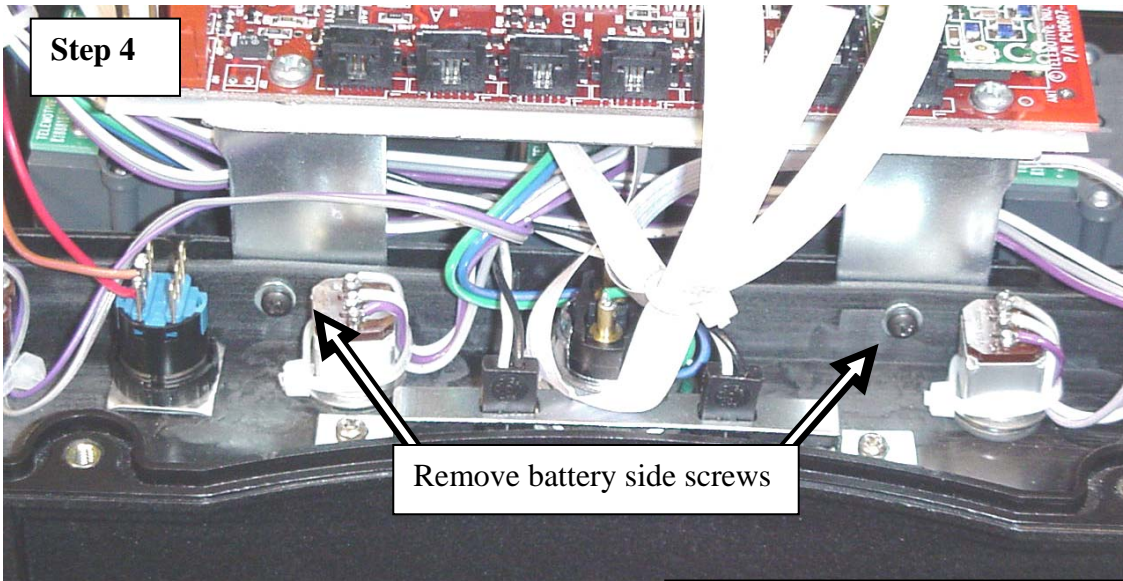

Remove the four mounting bracket screws on the battery side, right and left sides of the mounting bracket. Two screws are on the battery side. (It might be necessary to remove a toggle switch to access the screw. Unscrew toggle switch nut from topside if necessary with a pliers). One each screw is on the left and right sides of the bracket.

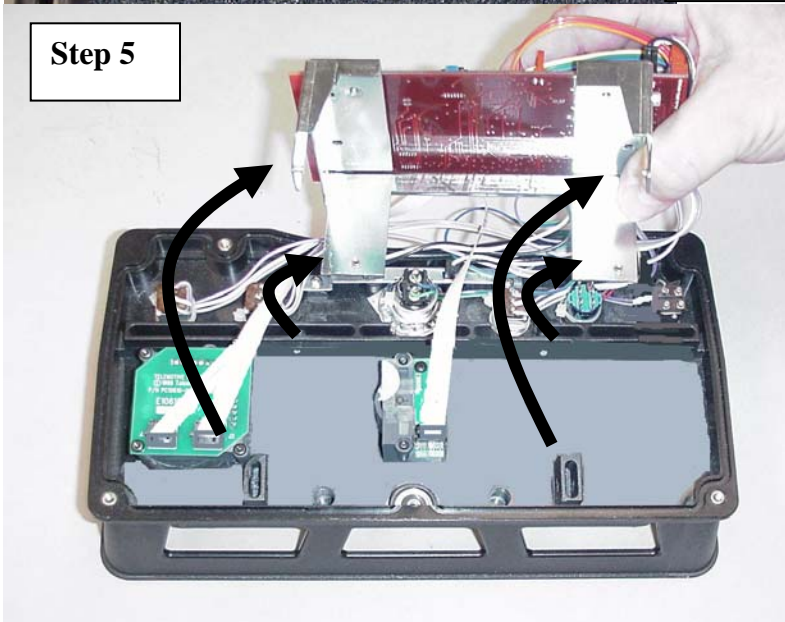

With four screws removed, lift up and fold back logic board and bracket assembly. Thus revealing levers and joysticks.

Tag ends of cables as to exactly which position on the lever and joystick they are connected too.

Note the orientation (left and right) of the joystick cables.

Step 6

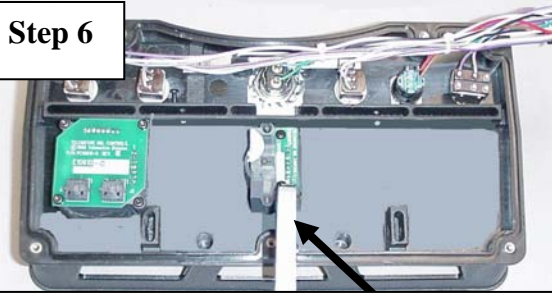

REMOVE CABLE (S) ON THE LEVER AND/OR JOYSTICK, BY PRESSING ON THE LOCKING TAB ON THE CONNECTOR

Step 7

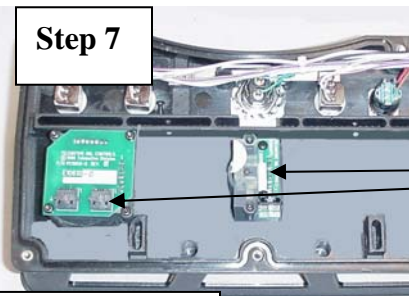

Note the orientation of the connector(s). The new switch must be installed the same way. If replacing a joystick note which cable went to which connector.

Step 8

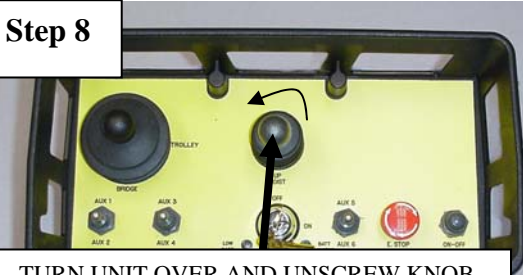

TURN UNIT OVER AND UNSCREW KNOB, COUNTERCLOCKWISE.

Step 9



PULL RUBBER BOOT OFF KNOB. FORCE MAYBE REQUIRED IF GLUED.

Step 10

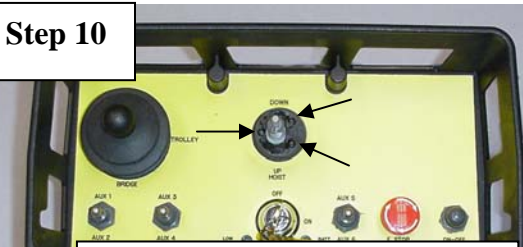

REMOVE THREE SCREWS USE A T7 TORX® DRIVER FOR LEVERS AND A T9 OR T10 FOR JOYSTICKS.

Step 11



PULL LEVER OR JOYSTICK SHAFT OUT.

Step 12

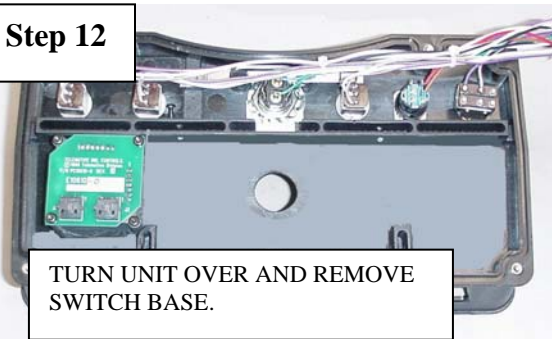

TURN UNIT OVER AND REMOVE SWITCH BASE.

Step 13

Note: Joysticks are similar to levers; only joysticks have two contact wipers see below.

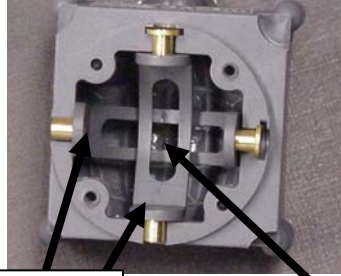

Contact wiper(s)

Notch(s)

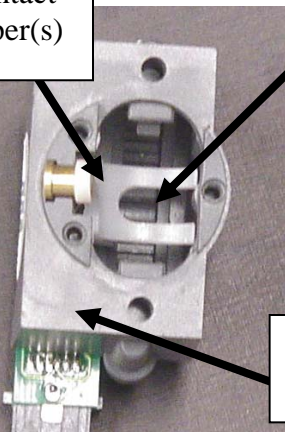
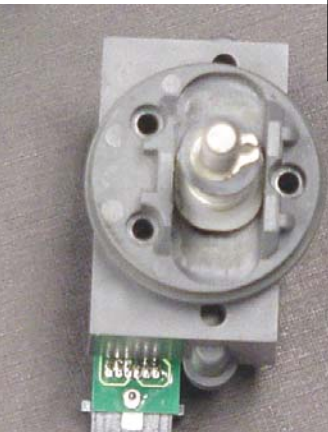

Lower half assembly

Remove on the new replacement part knob, boot, three screws and shaft assembly.
CAUTION : CAREFULLY REMOVE LEVER OR JOYSTICK SHAFT BY PULLING STRAIGHT OUT SO THAT CONTACT WIPER DOES NOT COME OUT

Do not remove if possible!

Do not remove if possible!



Lever assembly shown apart.

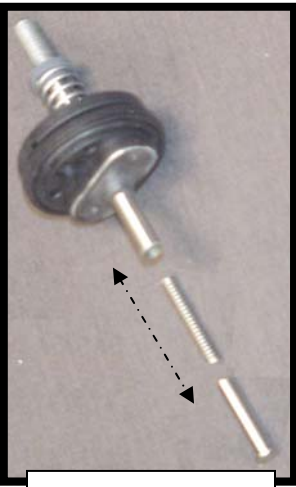

Shaft, spring and plunger assembly



Joystick assembly shown apart.

Step 14. New lever or joystick installation

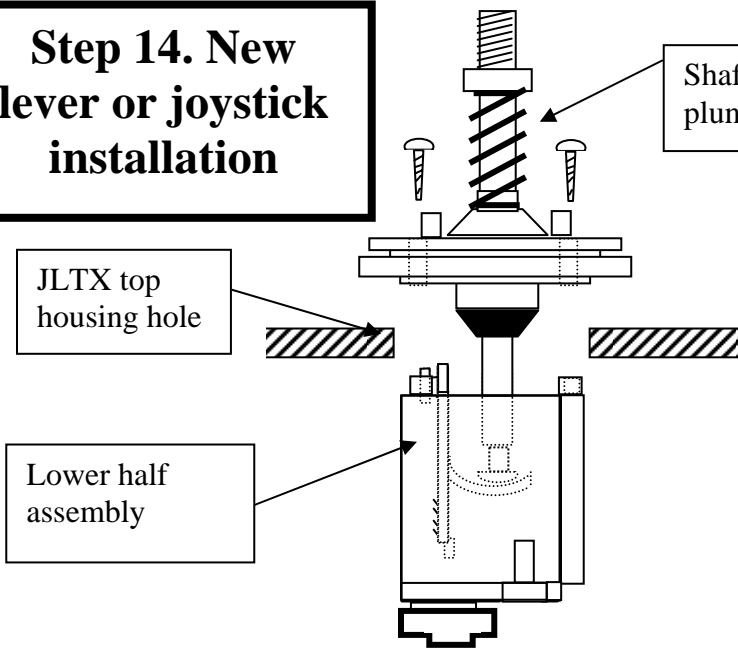

1. Position lower half assembly (with contact wiper in place) in hole in JLTX top housing from bottom of JLTX top housing.
2. Drop shaft spring and plunger assembly in from top, making sure plunger goes between the notch(s) in contact wiper(s).
3. Align screw holes and screw screws in place till snug. Do not tighten.

CAUTION: If the contact wiper comes out of the lower half assembly, be **EXTREMELY** careful to not touch or bend the metal contact fingers on the contact wiper. They are very easy to bend. If they are bent the switch will malfunction and cannot be repaired. See below to replace contact wiper assembly.

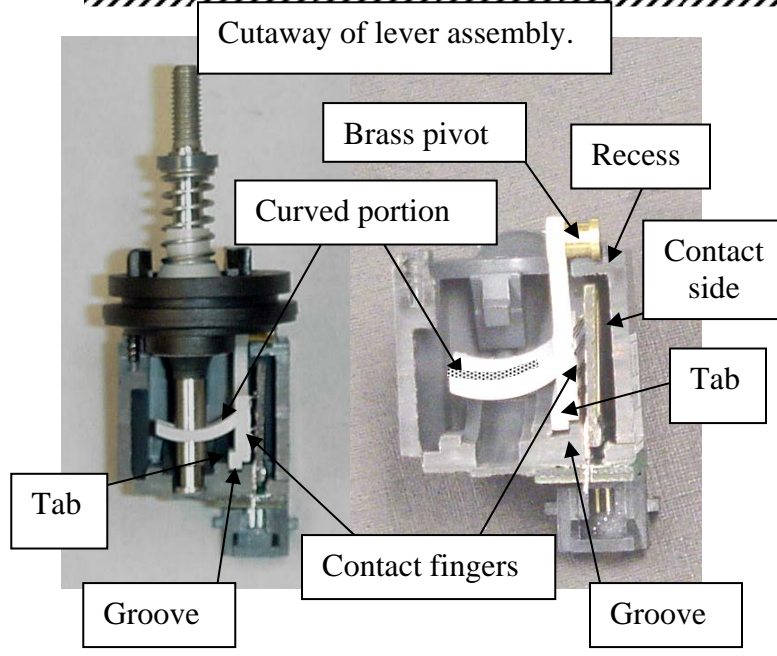

Contact wiper re-installation.
Only if necessary!

- If the contact wiper comes out and the contact fingers have not been damaged, the contact wiper can be reinserted. If the fingers are damaged they **CANNOT** be repaired.
- Carefully** use the following procedure:
1. Holding the switch base in one hand with the other hand tip the contact wiper to insert it curved portion first. For joysticks inset the contact wiper with the deepest curve first.
 2. Straighten the contact wiper(s) and lower with slight pressure towards the contact side until the tab at the end of the contact wiper inserts in the groove in the base.
 3. Seat the brass pivot point(s) in the recess.
 4. Feel if the contact wiper moves freely.

Step 15. Lever or joystick checkout.

Align the lever or joystick for proper connector orientation (refer to Step 5) and alignment.

Tighten screws till the lever will not rotate. Do not tighten too hard they will strip. (Maximum torque specification is 2 in-lbs).

Feel the action of the lever or joystick, if it binds or does not move smoothly take apart and reassemble.

Step 16. Re-assembly of unit.

Reverse the procedure followed in Steps 2 through 7.

Plug in lever or joystick cable(s).

Replace logic board mounting bracket assembly.

Replace the four mounting bracket screws.

Re-connect cables to logic board.

Replace bottom cover and gasket. Note gasket orientation see below:

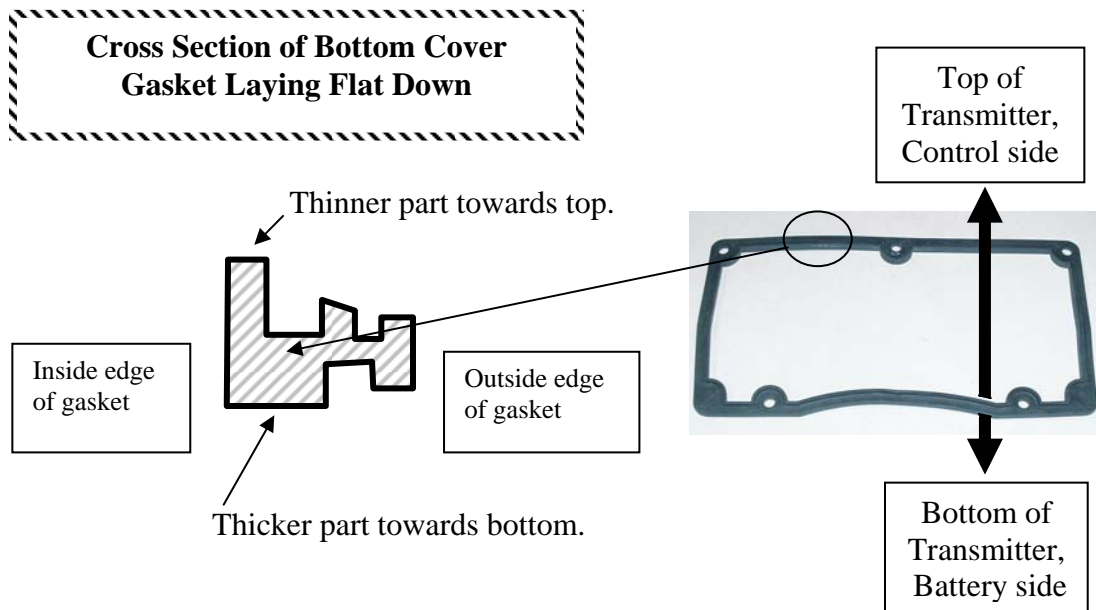

NOTE: The gasket has a topside and bottom side. The way you can tell top from bottom is to compare the relative thickness of the inside edges of the gasket looking flat down on it. The side with the thinner portion of the gasket on the inside edge faces up towards the top. The side with the thicker portion on the inside edge of the gasket goes down towards the bottom of the transmitter.

Step 17. Boot Ring and Knob Installation.

Replace boot. For **LEVERS ONLY** follow the alignment procedure below (joystick boot alignment is not critical)

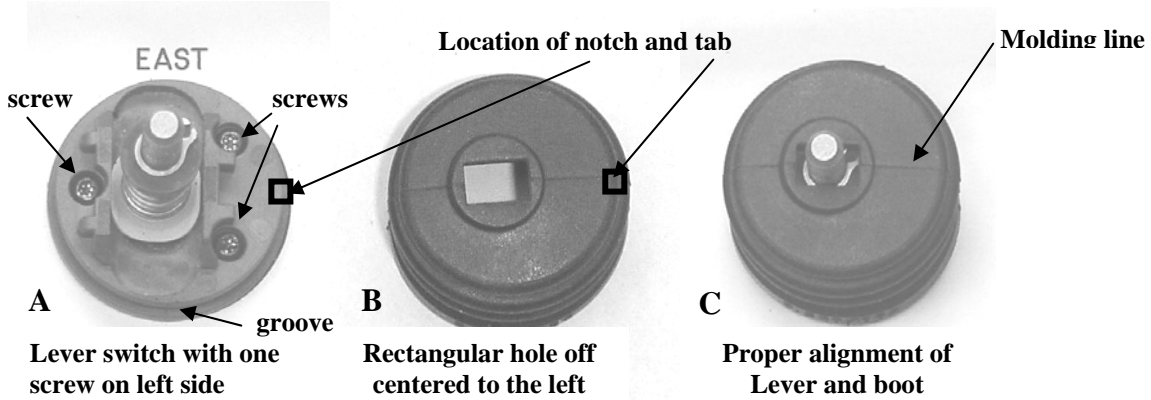

Figures 17-A, B, and C.
Boot and Lever Switch Detail.

Press locking ring over boot till firmly seated against top housing. (See below):

Part numbers for retaining rings are:

MP2300-0 Spring, Joystick Retaining

MP2301-0 Spring, Lever Retaining

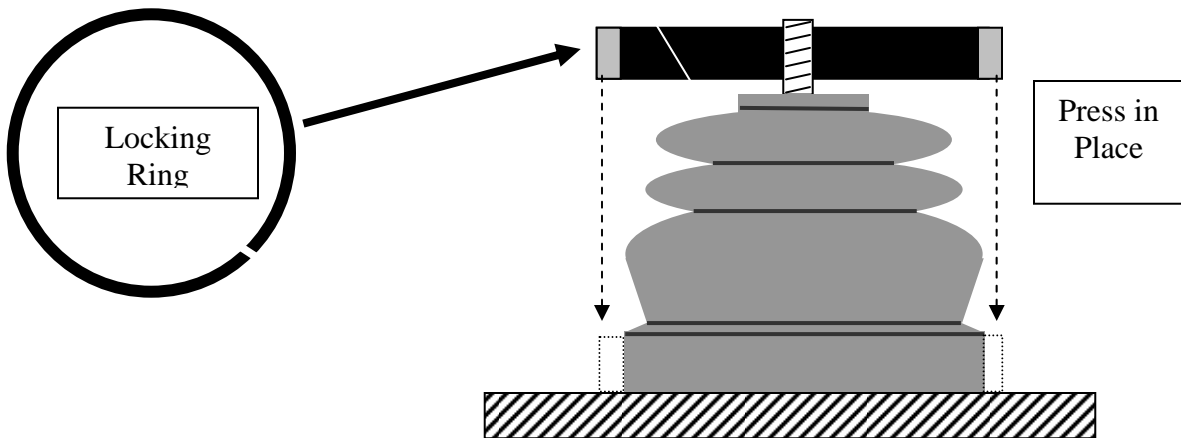

Ring Installation Detail

Replace knob. (Turn clockwise to screw on).

Assembly is now complete go to Step 18 for testing of unit.



WARNING

THE INCORRECT OPERATION OF A LEVER OR JOYSTICK CAN CAUSE AN EQUIPMENT MALFUNCTION FAILURE TO FOLLOW THIS TEST AND NOTIFICATION PROCEDURES ON THIS PAGE CAREFULLY COULD RESULT IN SERIOUS INJURY OR DEATH AND DAMAGE TO EQUIPMENT

Step 18. Test unit.

Replace battery.

Turn unit on.

(If the ON light continues to flash rapidly there is a lever or switch stuck ON).

Test the unit using the receiver with the Master Control Relay disabled so no power is applied to the crane motors during receiver operation. (See the receiver manual for procedure). This is done to check out the controller functions without causing crane movement.

Verify ALL functions completely, especially the E-STOP function.

If the unit functions properly, engage the Master Control Relay and retest the functions with the crane controls live.

Test initially using a nudging motion on the lever or joystick to see if motion is correct.

IMPORTANT IF ANY SWITCH MALFUNCTIONS HIT E-STOP IMMEDIATELY!

If you need help with troubleshooting please call Magnetek's Technical Support Team at 1-866-MAG-SERV (1-866-MAG-SERV). For Canadian customers, please call Canada Service at 1-800-792-7253.

Step 19. Return to service.

If the unit tests correctly return the transmitter to the crane operator.

Inform the operator and/or supervisor that a lever or joystick has been replaced and review with him the use of the E-STOP in an emergency. Tell the operator to report a malfunction or improper operation immediately.