

# Yale YK Wire Rope Hoist

Top-Running Hoist and Trolley

Customer Name: QUOTATIONS CUSTOMER  
 Quote Number: 7NT6G, Line: 1  
 Revision Number: 1  
 Quote Date: 4/16/2020

## TECHNICAL DATA

Hoist Model Number	YKD-T07-093S225-2-72
Rated Lift Capacity	7.5 U.S. Tons
Maximum Lift Distance	93 ft (28.35 m)
Maximum Lifting Speed	25 ft/min (7.62 m/min)
Reeving Style	2-Part Single-Reeved
Hoist Control Type	Two-Speed
Hoist Suspension Type	Top Running Trolley
Bridge Rail Size Min. (lb/yd)	25#
Bridge Rail Size Max. (lb/yd)	60#
Trolley Traverse Speed (60Hz)	80
Trolley Control Type	Two-Speed
Trolley Bumpers	Included
Hoist Duty Classification	HMI Class H4
Operating Voltage	460V / 3ph / 60Hz
Control Voltage	120 VAC
Trolley Motor HP	0.9
Trolley Motor Qty	1
Base Weight of Hoist (lbs)	2658.4282

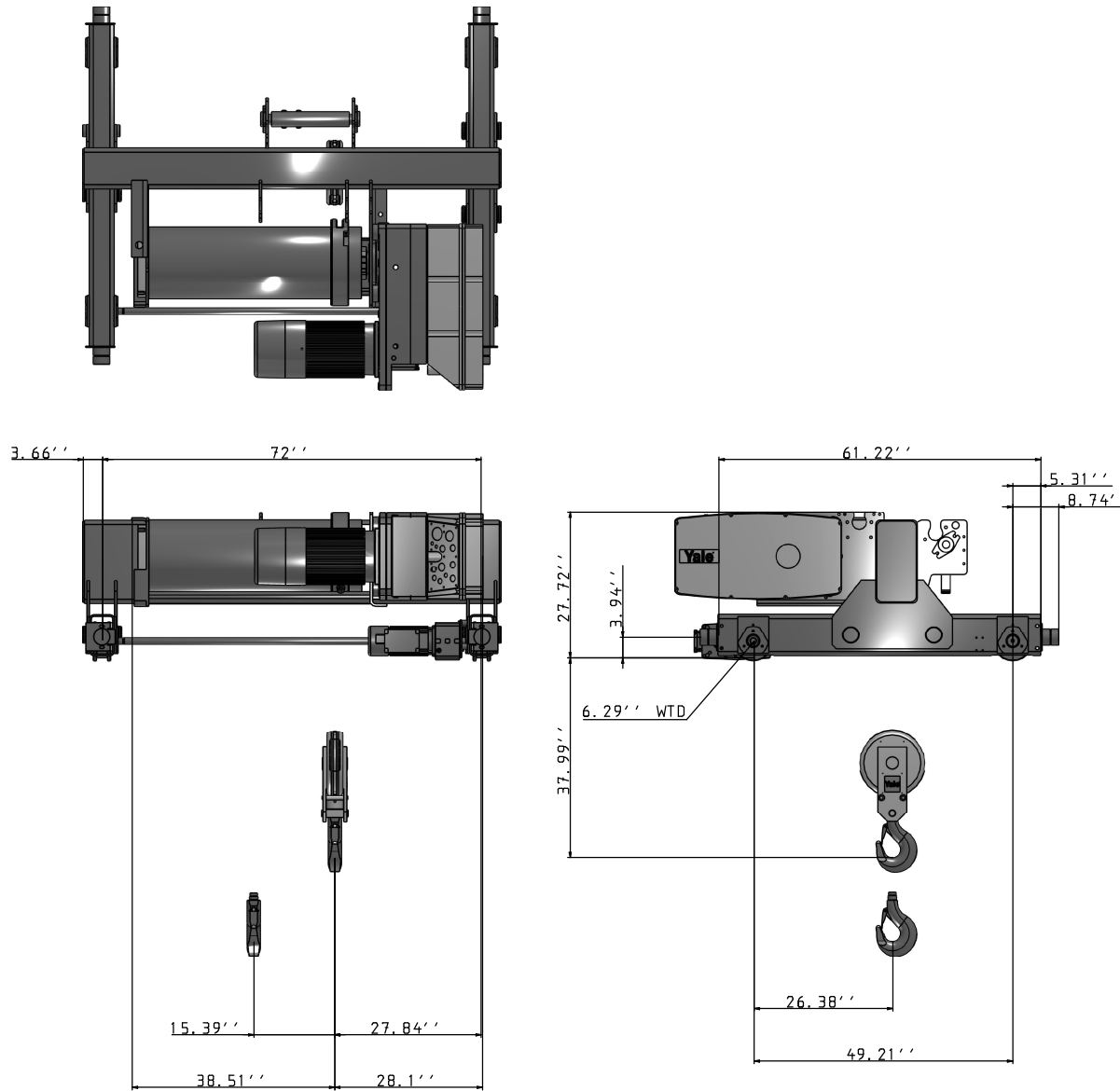

This document was generated by COMPASS®  
 by Columbus McKinnon Corporation  
 Getzville, New York USA

This drawing is intended for preliminary reference use only and depicts general clearance dimensions based on standard product configuration. If your application includes specific critical dimensional constraints it is recommended that an Approval Drawing be requested at time of order.

